

Cutter H Series 685.2

64, 90, 120, 140, 168 and 222 mm

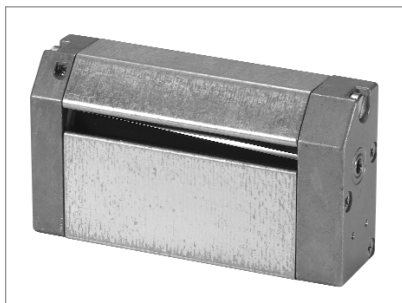

- High cutting capacity
- Variable cutting width
- Compact design
- Knife guard
- Easy to install

SPECIAL FEATURES

- Paper channel width 64 to 222 mm
- Permissible paper weight 60 – 200 g/m²
- Operating voltage 12 or 24 V DC
- Sturdy metal construction
- Integrated motor drive
- Full cut

MECHANICAL CONSTRUCTION

Metal housing, bright finish with bright metal side parts and zinc metal covers on drive and knife side.

FUNCTIONAL DESCRIPTION

This cutter works with a self-sharpening rotary knife, resulting in a high number of cuts. A DC motor and a multiple reduction gear provide for a powerful drive with comparatively low power consumption.

After cutting has been triggered by a starting pulse, the cutting procedure itself is carried out automatically until the rotary knife is slowed down again in its home position without wear.

STANDARD VERSIONS

Operating voltage in VDC	Paper channel width in mm	Permissible paper weight in g/m ²	Artikel-Nr.
12	64	200	0 685 200
24	64	200	0 685 201
12	90	200	0 685 202
24	90	200	0 685 203
12	120	200	0 685 204
24	120	200	0 685 205
12	140	160	0 685 206
24	140	160	0 685 207
12	168	160	0 685 208
24	168	160	0 685 209
12	222	80	0 685 210
24	222	80	0 685 211

TECHNICAL DATA

Paper channel width	64 - 222 mm	
Permissible paper weight	for paper channel width 64,90 und 120 mm	200 g/m ²
	for paper channel width 140 und 168 mm	160 g/m ²
	for paper channel width 222 mm	80 g/m ²
Operating voltage	12 V DC ± 10 %	24 V DC ± 10 %
Power consumption	at start up	2,2 A
	in operation	0,5 A
Cutting start	by SPDT contact	
Pulse length	150 - 350 ms	
Cutting cycle	550 ms	
Climate	IEC 60721 3-3, 3K3 without condensation	

Cutter H

Series 685.2

64, 90, 120, 140, 168 and 222 mm

TECHNICAL DATA

Service life	for permissible paper weight	500.000 cuts
Weight	for paper channel width 64 mm	330 g
	for paper channel width 90 mm	380 g
	for paper channel width 120 mm	415 g
	for paper channel width 140 mm	445 g
	for paper channel width 168 mm	485 g
	for paper channel width 222 mm	600 g
Dimensions (W x D x H) in mm	for paper channel width 64 mm	50 x 25 x 91
	for paper channel width 90 mm	50 x 25 x 117
	for paper channel width 120 mm	50 x 25 x 147
	for paper channel width 140 mm	50 x 25 x 167
	for paper channel width 168 mm	50 x 25 x 197
	for paper channel width 222 mm	50 x 25 x 249

SUGGESTED CONNECTION DIAGRAM 1

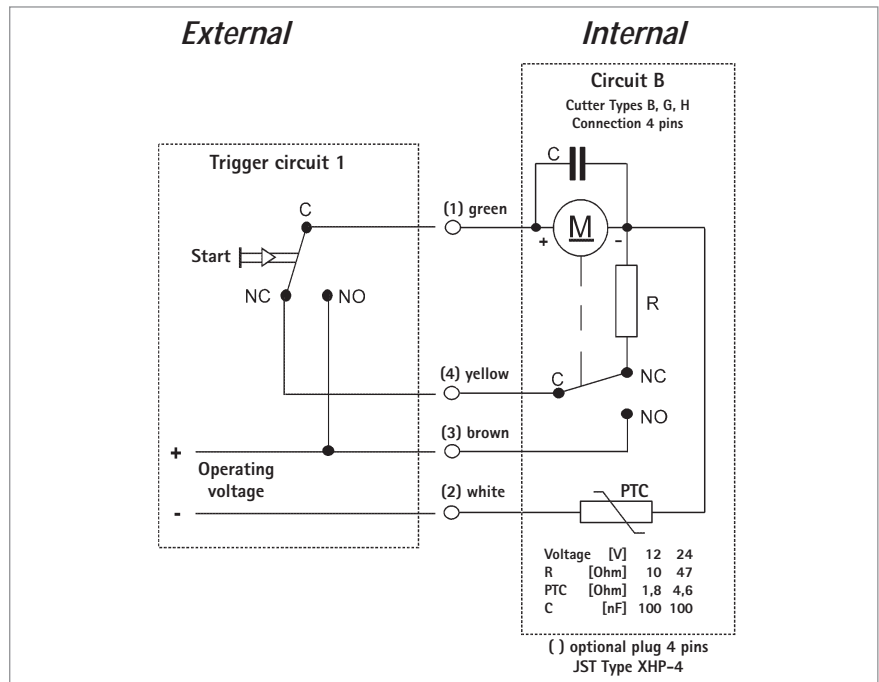

SUGGESTED CONNECTION DIAGRAM 2

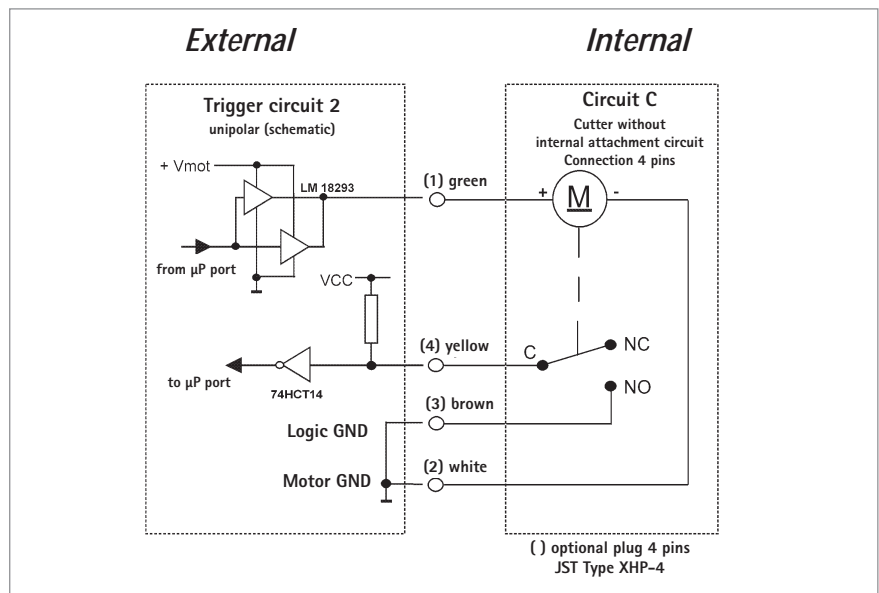

Cutter H Series 685.2

64, 90, 120, 140, 168 and 222 mm

TYPE CODE

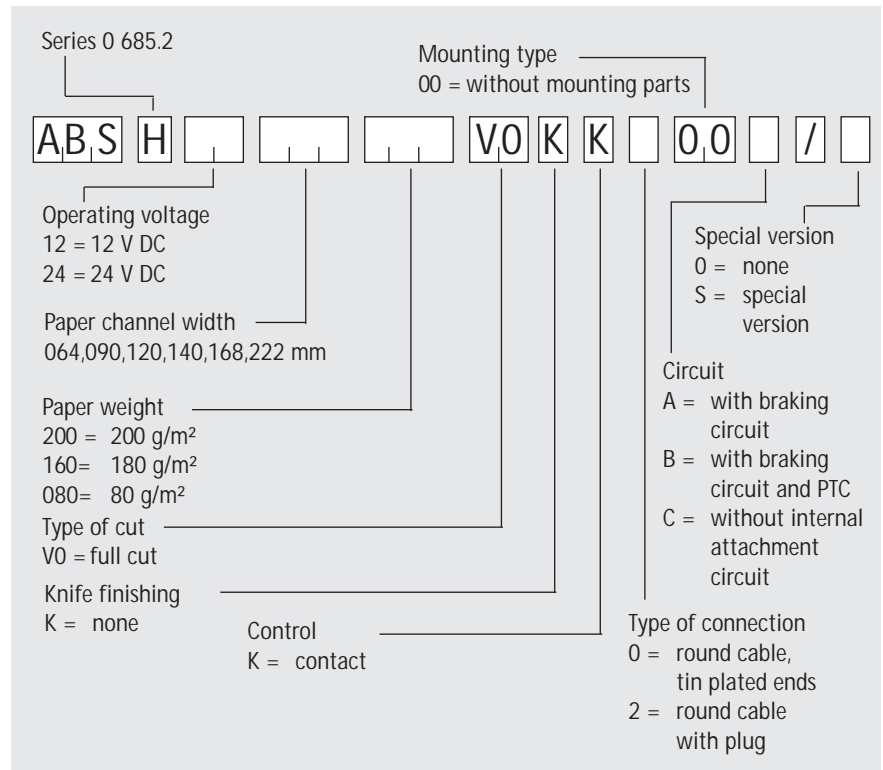

EXAMPLE FOR ORDER INFORMATION

Designation	Item No.
ABS H 24 120 200 VO KK000B/0	0 685 205

DIMENSIONED DRAWINGS

Dimensioned drawing	Filename
Cutter H	1 685 988.pdf

MANUALS

Designation	Filename
Installation manual, German	2 685 638.pdf
Installation manual, English	2 685 639.pdf
Installation manual, French	2 685 640.pdf

Please find the up to date dimensioned drawings/documents as PDF-files on our homepage <http://www.hengstler.com> or request them by e-mail, fax or post from us.
All technical data is subject to alterations.