



Normally closed safety edges SL NC II



EN | Product information

Mayser GmbH & Co. KG

Örlinger Straße 1-3

89073 Ulm

GERMANY

Phone: +49 731 2061-0

Fax: +49 731 2061-222

E-mail: info.ulm@mayser.com

Internet: www.mayser.com

Contents

Definitions	4
Pressure-sensitive protection device	4
Operation principle 2-wire-technology	5
Safety	7
Intended use	7
Limits	7
Exclusions	7
Other safety aspects	8
Design	8
Effective actuation area	9
Installation position	9
Connection	10
Cable exits	10
Cable connection	11
Wire colours.....	11
Connection examples	12
Sensor surface	13
Physical resistance.....	13
Chemical resistance	13
Attachment	14
Aluminium profile C 26M.....	14
Aluminium profile C 26.....	15
Aluminium profile C 36M.....	15
Aluminium profile C 36L.....	16
Aluminium profile C 36S	16
Aluminium profile C 36.....	17
Aluminium profiles: Overview of combinations	17
SL NC II: The right selection	18
Calculation for selection of the safety edge height.....	18
Calculation examples	18
Accessories	20

Copyright

The reproduction, distribution and utilization of this document as well as the communication of its contents without express authorization are prohibited. Offenders will be held liable for the payment of damages. All rights reserved in the event of the grant of a patent, utility model or design.

© Mayser Ulm 2020

Maintenance and cleaning	20
Technical data	21
GP 48-2 NBR with C 26.....	21
GP 48-2 EPDM with C 26.....	23
GP 65-2 EPDM with C 36.....	25
GP 100-2 EPDM with C 36.....	27
Conformity	29
Conformity.....	29
EC design test.....	29
UL certification	29

Definitions

Pressure-sensitive protection device

A pressure-sensitive protection device consists of pressure-sensitive sensor(s), signal processing and output signal switching device(s). A pressure-sensitive protection device with switching type NC combines a sensor and an output signal switching device. That means that such a pressure-sensitive protection device can be used without a control unit. The pressure-sensitive protection device is triggered when the sensor is activated.

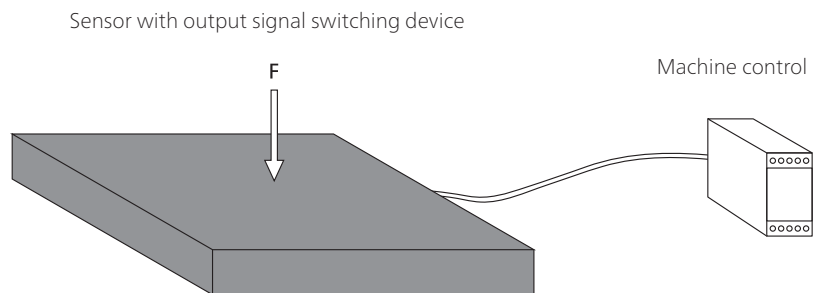

Sensor

The sensor is the part of the pressure-sensitive protection device that generates a signal when the actuating force F is applied. Mayser safety systems have a sensor whereby the actuating surface is deformed locally.

Signal processing

A pressure-sensitive protection device with switching type NC is designed only with an input and output unit for signal processing. The output unit is connected directly to the downstream control.

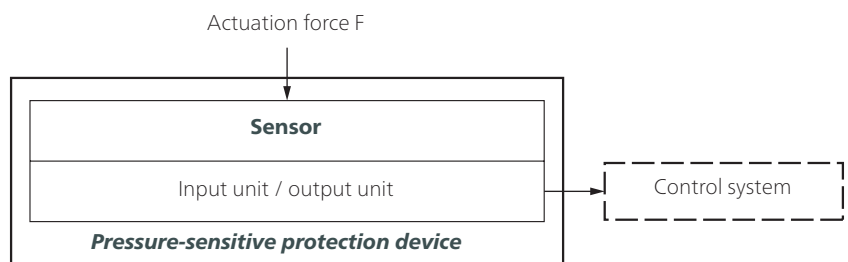

Tip: Terms are defined in ISO 13856-1, Chapter 3.

Criteria for selecting the sensor type

- Category according to ISO 13849-1
- Performance level of pressure-sensitive protection device = at least PL_r
- Temperature range
- Degree of protection in accordance with IEC 60529:
IP67 is the standard for safety edges.
Higher degrees of protection must be checked individually.
- Environmental influences such as swarf, oil, coolant, outdoor use...
- Finger detection necessary?

Tip: For additional sensor selection criteria, please refer to ISO 13856-2 Appendix C and Appendix E.

Operation principle 2-wire-technology

The sensor is designed with integrated **positive break** safety elements in the form of contact chains. A control unit is not necessary, since the NC contact principle provides the output signal directly to the downstream control.

Optionally, the sensor can also be operated with an emergency stop component or a control unit.

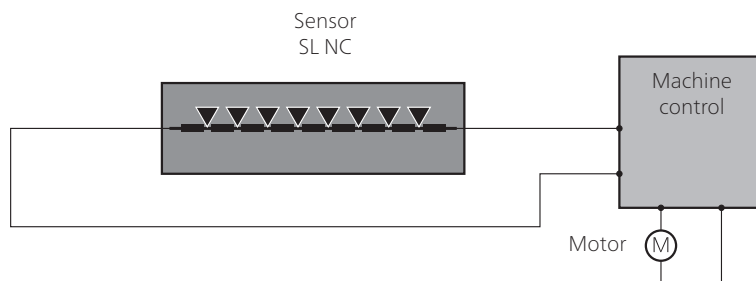

For your safety:

Sensor and connecting cables are constantly monitored for function. This is possible because of signal transmission feedback – without a monitoring resistor.

Design

SL NC with two 1-strand cables as a through sensor



Combination of sensors

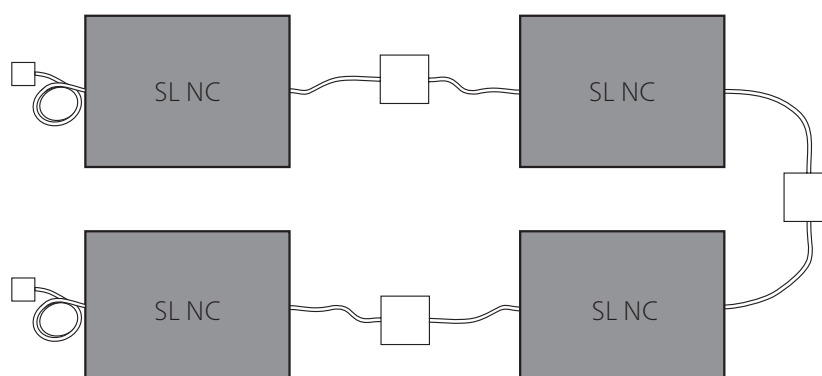

Combination:

- Connection of more than one sensor
- only one emergency stop component necessary
- Safety edge design with custom lengths and angles

Subject to technical modifications.

Safety

Intended use

A safety edge detects a person or part of the body when pressure is applied to the actuation area. It is a linear tripping device. Its task is to avoid possible hazardous situations for a person within a danger zone, such as shearing and pinching edges.

Typical areas of application are door and gate systems, moving parts on machines, platforms and lifting devices.

Safe operation of a safety edge depends entirely on

- the surface condition of the mounting surface,
- the correct selection of the size and resistance as well as
- correct installation.

For additional application guidelines refer to ISO 13856-2 Annex E.

Due to the design, the visible actuation area is reduced by the non-sensitive edges. What remains is the actual effective actuation area (see chapter *Effective actuation area*).

Limits

A maximum of 10 sensors may be operated in series.

GP 48-2 deviates with respect to the actuation angle from the requirements in ISO 13856-2 and EN 12978; the suitability for doors and gates must be examined on an individual basis.

Exclusions

The sensors are not suitable:

- for detecting fingers
- for areas of application with high levels of vibration
- for performing a sealing function. Continuous actuation can cause permanent damage to sensors.

Other safety aspects

Performance Level (PL)

The PL was determined during a simplified procedure according to ISO 13849-1. Exclusion of error according to ISO 13849-2, Table D.4: Short circuit between two conductors that are permanently installed and protected against external damage. In this case the diagnostic coverage (DC) of the cables is not calculated and is not used in determining the PL. Assuming the control unit has a high $MTTF_D$ value, the entire safety edge system (pressure-sensitive safety device) can achieve the maximum value PL d.

Is the safeguard appropriate?

The PL required for the hazard must be decided by the integrator. This is followed by the choice of safeguard.

Finally, the integrator needs to check whether the category and PL of the safeguard chosen are appropriate.

Risk and safety assessment

For the risk and safety assessment of your machine we recommend ISO 12100 „Safety of machinery – general principles for design“.

Without reset function

When a safeguard without a reset function is used (automatic reset), the reset function must be made available in some other way.

Design

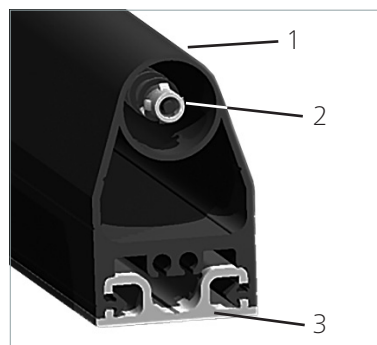

The Normally closed safety edge SL/NC II consists of
(1) Rubber profile GP,
(2) Contact chain made of connected positive break normally closed contacts and
(3) Aluminium profile C 26 or C 36.

The positive break contact chain simultaneously carries out the functions of the sensor, signal processing and output signal switching device. Therefore, a special control unit is not necessary.

Subject to technical modifications.

Effective actuation area

The parameters X, Y, Z, L_{WB} and the angle α describe the effective actuation area.

For the effective actuation area, the following applies:

$$L_{WB} = L_{SL} - 2 \times L_{NE}$$

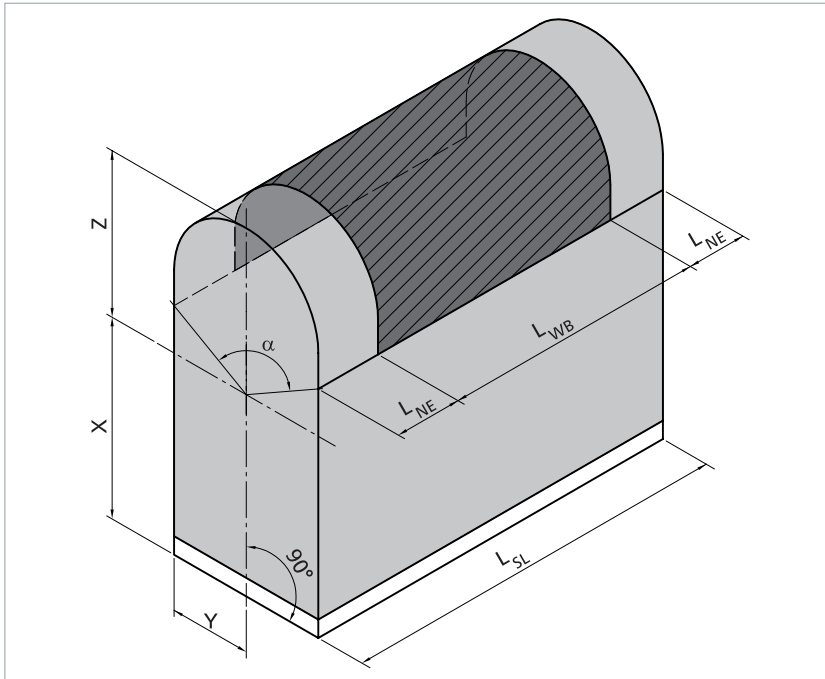

Parameters:

L_{WB} = effective actuation length
 L_{SL} = overall length of the safety edge

L_{NE} = non-sensitive length at the end of the safety edge

α = effective actuation angle

SL NC II	GP 48-2	GP 65-2	GP 100-2
α	60°	90°	90°
L_{NE}	50 mm	50 mm	40 mm
X	40 mm	52 mm	85 mm
Y	13 mm	18 mm	18 mm
Z	8 mm	13 mm	14 mm

The effective actuation angle α (60°) for GP 48-2 falls below the requirements of ISO 13856-2 and EN 12978.

Installation position

The installation position can be selected as required, i.e. all installation positions A to D as per ISO 13856-2 are possible.

Connection

Cable exits

90° exit

Distance to front end each 60 mm

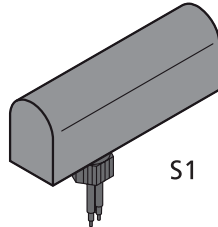

S1

S1: 1 connection

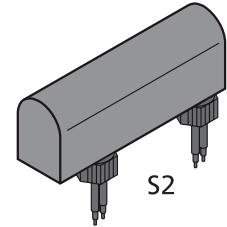

S2

S2: 2 connections

Lateral exit

Distance to front end each 60 mm

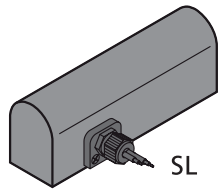

SL

SL: lateral exit left

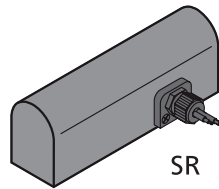

SR

SR: lateral exit right

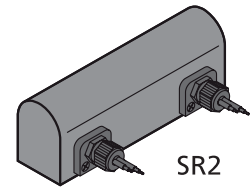

SR2

SR2: 2 connections

Axial exit

without PG-screw connection

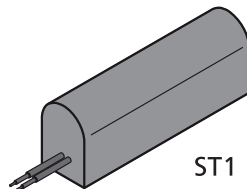

ST1

ST1: Axial exit

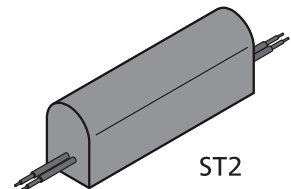

ST2

ST2: 2 connections

In the case of several sensors connected in sequence, we recommend version S2, SR2 or ST2. These versions provide an additional line in the rubber profile for feedback to the control.

Subject to technical modifications.

Cable connection

- Cable: Ø 3.3 mm PVC, 1× 0.5 mm²; double insulated, short-circuit-proof, highly flexible
- Cable length depends on the sensor length:
A cable with a length of 7.5 m is installed in the sensor as standard equipment. Due to internal cable routing from the connections the cable exits, the connection cable length is determined as follows:
Standard cable length minus sensor length.
For example, 7.5 m - 6 m = 1.5 m
Option: can be expanded up to a maximum length of 100 m
- Cable ends: wires stripped
Option: Cable ends available with plug and coupling

For the wiring between the sensor and the downstream control the cables must be installed permanently and protected against external damage, for example in cable conduits or armoured conduits. In areas where this is not possible, each cable must be routed in a separate sheath.

This prevents

- line termination and therefore loss of the protective function and
- downgrading of the safety classification.

Wire colours

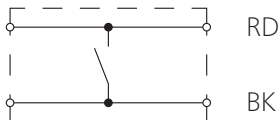

Colour coding

BK	Black
RD	Red

Connection examples

Connection example 1

NC safety edge connected directly to the control. Protective devices in accordance with ISO 13849 1 to PL d are possible, if the control has a performance level of d or higher.

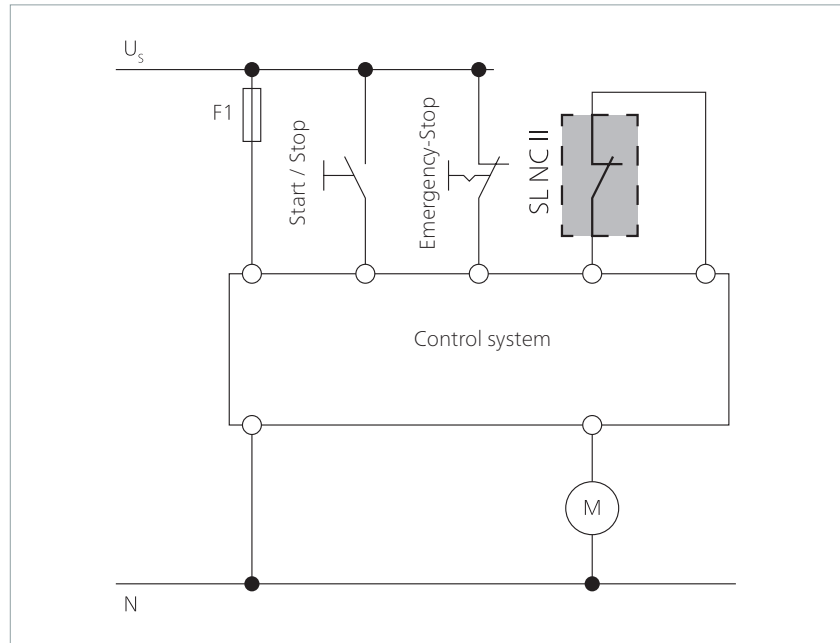

Connection example 2

NC safety edge connected to the Mayser SG-EFS 104/4L control unit. Performance level up to PL d in accordance with ISO 13849-1 is possible.

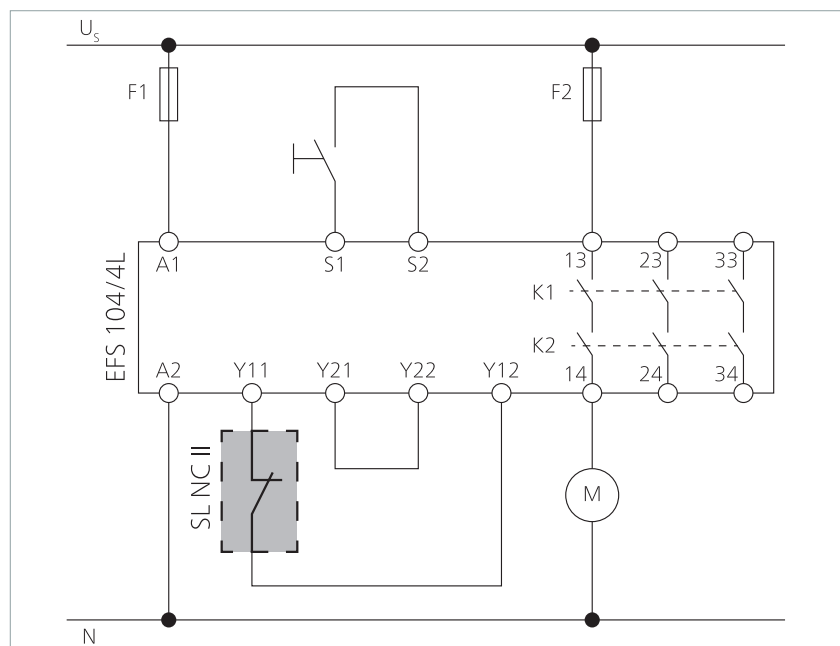

The NC safety edge and the SG EFS 104/4L sensor are certified to UL 508.

Subject to technical modifications.

Sensor surface

Physical resistance

Rubber profile GP	EPDM	NBR
Degree of protection (IEC 60529)	IP67	IP67
Hardness per Shore A	65 ±5	70 ±5

Chemical resistance

The sensor is resistant against normal chemical influences such as diluted acids and alkalis as well as alcohol over an exposure period of 24 hrs.

The specifications in the table are the result of tests conducted in our lab at room temperature (+23 °C). The suitability of our products for your special area of application must always be verified with your own practical tests.

Material	EPDM	NBR
Acetone	+	±
Formic acid	+	+
Ammonia	+	+
Petrol	-	+
Brake fluid	±	±
Chloride solutions	+	+
Diesel oils	-	+
Greases	-	+
Household-/sanitary cleaners	+	+
Isopropyl alcohol	+	+
Cooling lubricant	-	+
Metal working oil	-	+
Methyl alcohol	+	+
Oils	-	+
Ozone and weather conditions	+	-
Hydrochloric acid 10 %	+	+
Spirit (ethyl alcohol)	+	+
Carbon tetrachloride	-	+
Hydrogen peroxide 10 %	+	+
Water and frost	+	-

Explanation of symbols:

- + = resistant
- ± = resistant to a certain extent
- = not resistant

Attachment

The sensors are mounted directly to the dangerous main and secondary closing edges. The aluminium profiles C 26 and C 36 are used for mounting. The aluminium profiles are mounted with screws M5 or rivets.

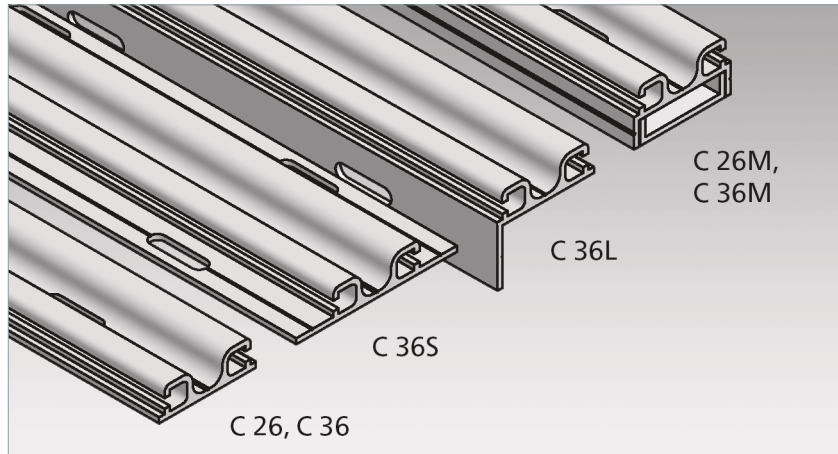

Material properties

- AlMgSi0.5 F22
- Wall thickness 2 mm
- Tolerances as per EN 755-9
- extruded
- hot hardened

Aluminium profile C 26M

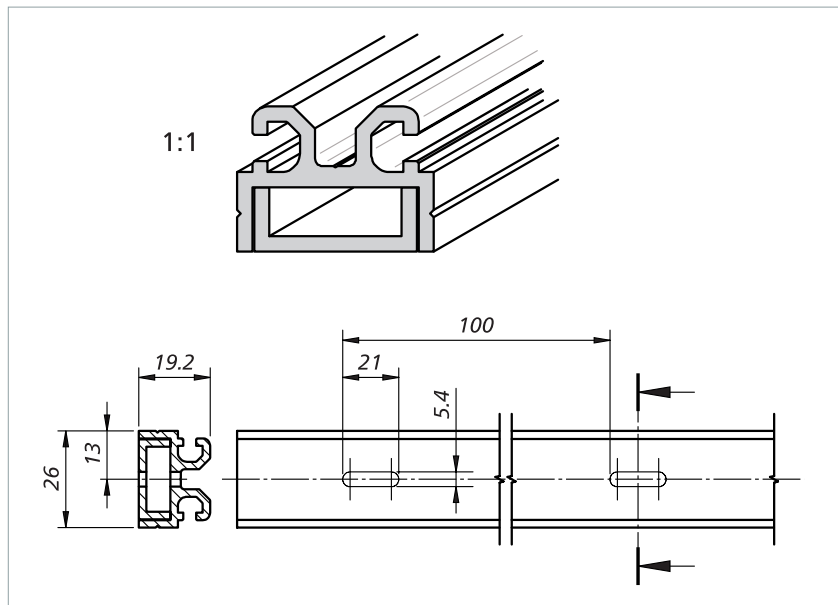

Two-part profile for GP 48-2:

For convenient assembly and disassembly. The rubber profile is clipped into the upper section and the upper section inserted in the installed lower section and fastened.

Subject to technical modifications.

Aluminium profile C 26

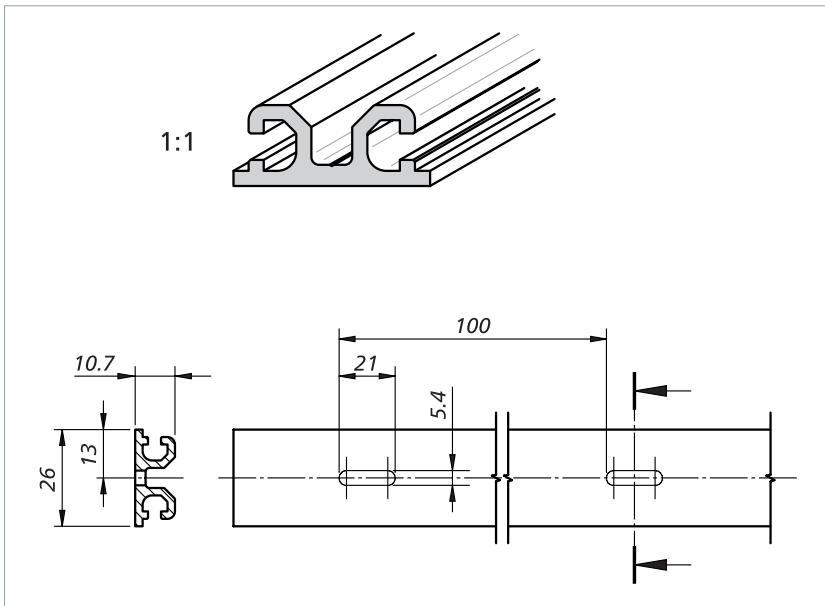

Standard profile for GP 48-2:

First the aluminium profile must be mounted to the closing edge and then the rubber profile clipped into the aluminium profile.

Aluminium profile C 36M

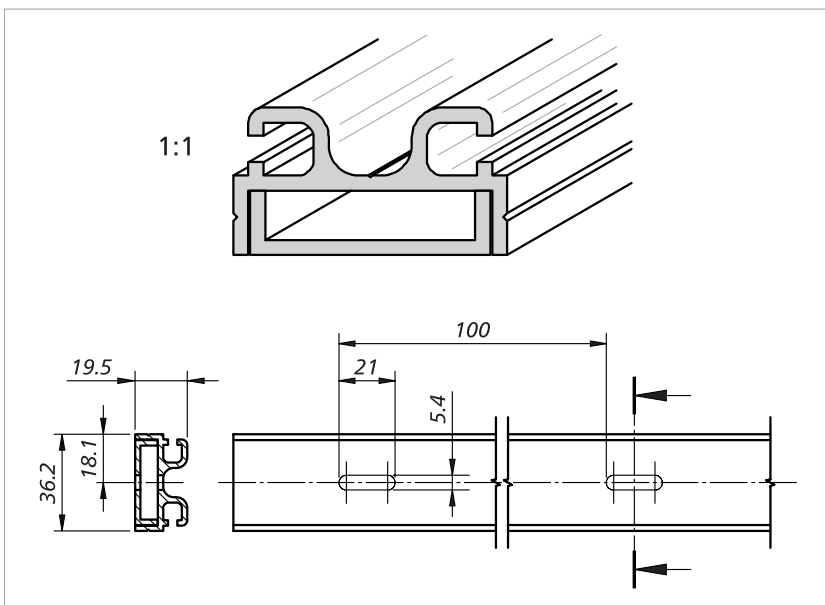

Two-part profile for GP 65-2 and GP 100-2:

For convenient assembly and disassembly. The rubber profile is clipped into the upper section and the upper section inserted in the installed lower section and fastened.

Subject to technical modifications.

Aluminium profile C 36L

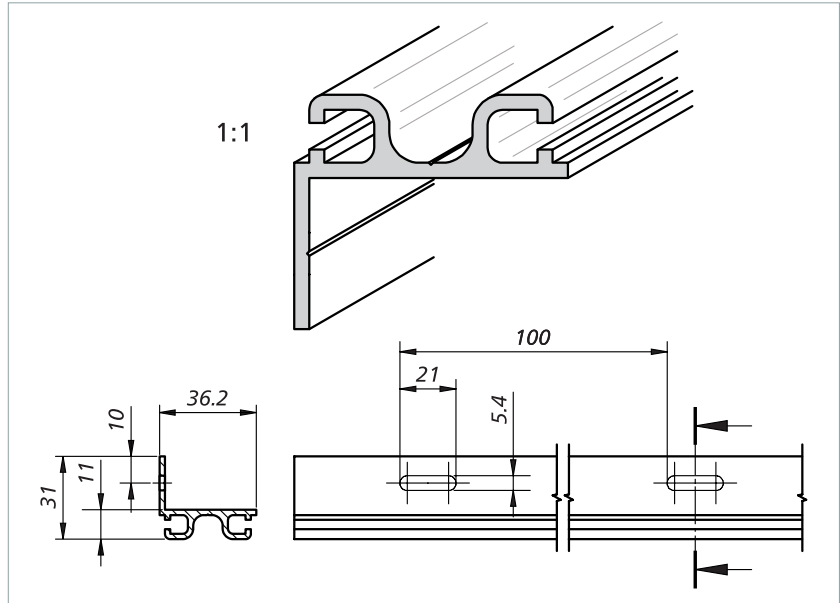

Angle profile for GP 65-2 and GP 100-2:

If the closing edge should or must not have assembly holes, this "round-the-corner" solution is suitable. Final assembly is also possible when the rubber profile is already clipped into the aluminium profile.

Aluminium profile C 36S

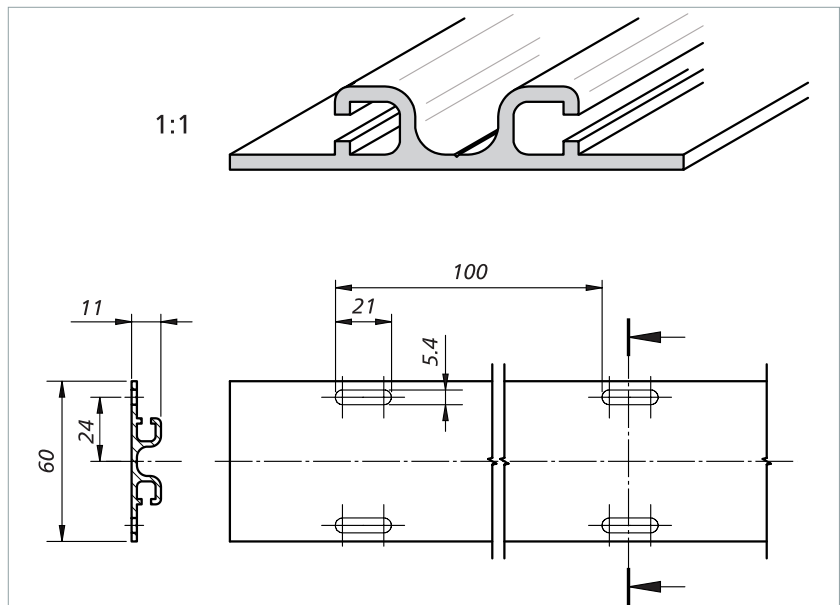

Flange profile for GP 65-2 and GP 100-2:

Final assembly is also possible when the rubber profile is already clipped into the aluminium profile.

Aluminium profile C 36

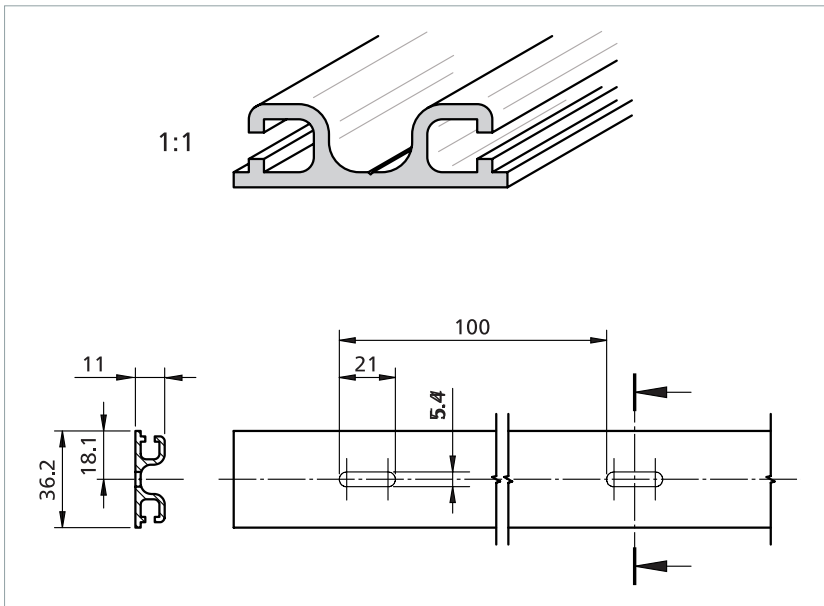

Standard profile for GP 65-2 and GP 100-2:

First the aluminium profile must be mounted to the closing edge and then the rubber profile clipped into the aluminium profile.

Aluminium profiles: Overview of combinations

Aluminium profiles for		GP 48-2	GP 65-2	GP 100-2
External clip bars	...-2 ⇨ ⇩ ⇩ ⇨	C 26 C 26M	C 36 C 36M, C 36L, C 36S	C 36 C 36M, C 36L, C 36S

SL NC II: The right selection

Calculation for selection of the safety

edge height

- s_1 = Stopping distance of the dangerous movement [mm]
- v = Velocity of the dangerous movement [mm/s]
- T = Follow-through of the complete system [s]
- t_1 = Response time safety edge
- t_2 = Stopping time of the machine
- s = Minimum overtravel distance of the safety edge so that the required limit forces are not exceeded [mm]
- C = Safety factor; if components susceptible to failures (braking system) exist in the system, a higher factor must be selected

The stopping distance of the dangerous movement is calculated using the following formula:

$$s_1 = 1/2 \times v \times T \text{ where: } T = t_1 + t_2$$

The NC safety edge is a sensor, signal processor and output signal switching device in one (see chapter *Design*). For this reason the response time t_1 of the safety edge = the sensor response time.

In accordance with ISO 13856-2, the minimum overtravel distance of the safety edge is calculated using the following formula:

$$s = s_1 \times C \quad \text{where: } C = 1.2$$

A suitable safety edge profile can now be selected based on the result. Overtravel distances of safety edge profiles: see chapter *Technical data*.

Calculation examples

Example 1

The dangerous movement on your machine has a velocity of $v = 10 \text{ mm/s}$ and can be brought to a standstill within $t_2 = 250 \text{ ms}$. The relatively low velocity suggests that a short overtravel distance is to be expected. Therefore the normally closed safety edge SL NC II GP 48-2 NBR could be sufficient. The response time of the safety edge is $t_1 = 1300 \text{ ms}$.

$$s_1 = 1/2 \times v \times T \quad \text{where: } T = t_1 + t_2$$

$$s_1 = 1/2 \times 10 \text{ mm/s} \times (1300 \text{ ms} + 250 \text{ ms})$$

$$s_1 = 1/2 \times 10 \text{ mm/s} \times 1.55 \text{ s} = \mathbf{6.55 \text{ mm}}$$

$$s = s_1 \times C \quad \text{where: } C = 1.2$$

$$s = 6.55 \text{ mm} \times 1.2 = \mathbf{7.86 \text{ mm}}$$

The safety edge must have a minimum overtravel distance of $s = 7,9 \text{ mm}$. The selected SL NC II GP 48-2 NBR has an overtravel distance of at least 12.4 mm . This is more than the required 7.9 mm .

Result: The SL NC II GP 48-2 NBR is **suitable** for this case.

Example 2

The same conditions as in calculation example 1 with the exception of the velocity of the dangerous movement. This is now $v = 100 \text{ mm/s}$. This reduces the response time of the safety edge to $t_1 = 83 \text{ ms}$.

$$s_1 = 1/2 \times v \times T \quad \text{where: } T = t_1 + t_2$$
$$s_1 = 1/2 \times 100 \text{ mm/s} \times (83 \text{ ms} + 250 \text{ ms})$$
$$s_1 = 1/2 \times 100 \text{ mm/s} \times 0.333 \text{ s} = \mathbf{16.65 \text{ mm}}$$

$$s = s_1 \times C \quad \text{where: } C = 1.2$$
$$s = 16.65 \text{ mm} \times 1.2 = \mathbf{19.98 \text{ mm}}$$

The safety edge must have a minimum overtravel distance of $s = 20 \text{ mm}$. The selected SL NC II GP 48-2 NBR has an overtravel distance of at least 16.8 mm. This is less than the required 20 mm.

Result: The SL NC II GP 48-2 NBR is **not suitable** for this case.

Example 3

The same conditions as in calculation example 2. Instead of SL NC II GP 48-2 NBR the SL NC II GP 100-2 EPDM is selected. The response time of the safety edge is $t_1 = 76 \text{ ms}$.

$$s_1 = 1/2 \times v \times T \quad \text{where: } T = t_1 + t_2$$
$$s_1 = 1/2 \times 100 \text{ mm/s} \times (76 \text{ ms} + 250 \text{ ms})$$
$$s_1 = 1/2 \times 100 \text{ mm/s} \times 0.326 \text{ s} = \mathbf{16.3 \text{ mm}}$$

$$s = s_1 \times C \quad \text{where: } C = 1.2$$
$$s = 16.3 \text{ mm} \times 1.2 = \mathbf{19.56 \text{ mm}}$$

The safety edge must have a minimum overtravel distance of $s = 20 \text{ mm}$. The selected SL NC II GP 100-2 EPDM has an overtravel distance of at least 36.8 mm at 100 mm/s. This is more than the required 20 mm.

Result: The SL NC II GP 100-2 EPDM is **suitable** for this case.

Accessories

Extension kit

For extension of connection cable by customer (contents: double insulated wire, crimp connector and heat-shrinkable sleeves)

Extension kit: 5 m 1003870

Extension kit: 10 m 1003871

Wiring aids

Special resistor: 1k Ω 1003873

Special resistor: 8k Ω 1003874

Maintenance and cleaning

The sensors are virtually maintenance-free.

Regular inspection

Depending on the utilisation, sensors must be inspected at regular intervals (at least monthly)

- for proper functioning,
- damage,
- and correct mounting.

Cleaning

If the sensors become dirty, they can be cleaned with a mild cleaning product.

Technical data

GP 48-2 NBR with C 26

Normally closed safety edge SL NC II consisting of sensor and aluminium profile from the profile range C 26.

Testing basis	
ISO 13856-2	
Switching characteristics at $v_{\text{test}} = 200 \text{ mm/s}$	
Switching operations	>10,000
Actuation force	
Test piece (cylinder) Ø 80 mm	< 150 N
Actuation distance	
Test piece (cylinder) Ø 80 mm	12 mm
Actuation angle	
Test piece (cylinder) Ø 80 mm	60°
Response time	60 ms
Finger detection	yes
Safety classifications	
ISO 13856: Reset function	without
ISO 13849-1:2015	Category 3 PL d
B_{10D} (Sensor)	2×10^6
Mechanical operating conditions	
Sensor length (min./max.)	30 cm / 6 m
Cable length (min./max.)	1.5 m / 100 m
Bend radii	not possible
Operating speed	
(min. / max.)	10 mm/s / 200 mm/s
max. load capacity	600 N
IEC 60529: Degree of protection	IP67
Humidity (max. at 23 °C)	95 % (non-condensing)
Operating temperature	+5 to +55 °C
Storage temperature	-20 to +80 °C
Weight	1.0 kg/m
Electrical operating conditions	
Contact transition resistance (max.)	5 Ohm
Number of sensors type BK	max. 10 in series
Switching voltage (PELV) (max.)	48 V DC
	48 V AC 50/60 Hz
Protection class	III
Switching current (max.)	20 mA
Contact fuse protection, external	250 mA slow-acting
Connection cable	Ø 3.3 mm PVC 1x 0.5 mm ²

Dimensions and distances

GP 48-2 NBR (1:2)

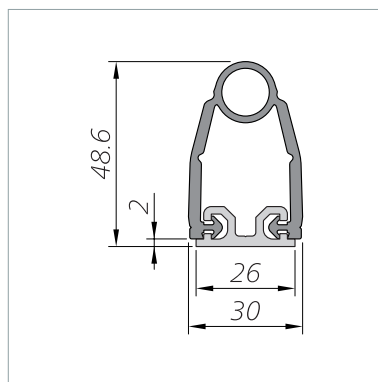

Dimensional tolerances according to ISO 3302 E2/L2.

Test conditions

according to ISO 13856-2

- Installation position B
- Temperature +20 °C
- Measurement point c3
- Test sample 1 with Ø 80 mm
- without control unit

All data stated here is documented in EC design type test certificates.

Force-distance ratios

Actuation force	69 N
Response time	1300 ms
Actuation distance (A)	13 mm
Overtravel distance	
up to 250 N (B1)	12.4 mm
up to 400 N (B2)	13.5 mm
up to 600 N (C)	14.9 mm
Total deformation	27.9 mm

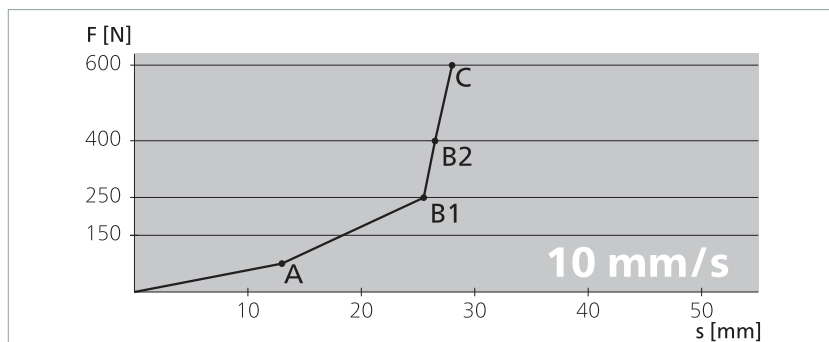

Actuation force	71 N
Response time	83 ms
Actuation distance (A)	8.3 mm
Overtravel distance	
up to 250 N (B1)	16.8 mm
up to 400 N (B2)	17.7 mm
up to 600 N (C)	18.9 mm
Total deformation	27.2 mm

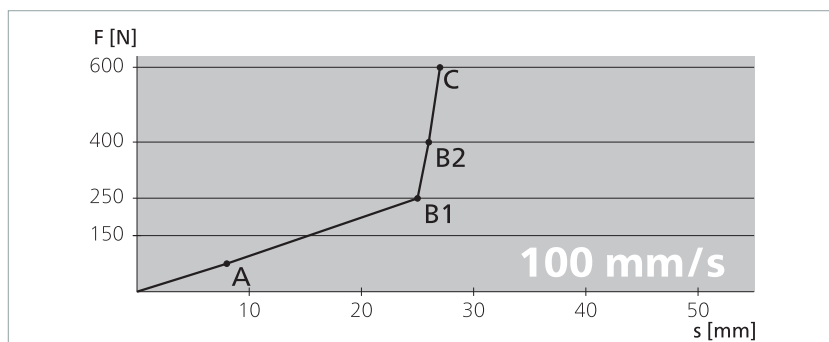

Actuation force	71 N
Response time	60 ms
Actuation distance (A)	12 mm
Overtravel distance	
up to 250 N (B1)	13.2 mm
up to 400 N (B2)	14.1 mm
up to 600 N (C)	15.2 mm
Total deformation	27.2 mm

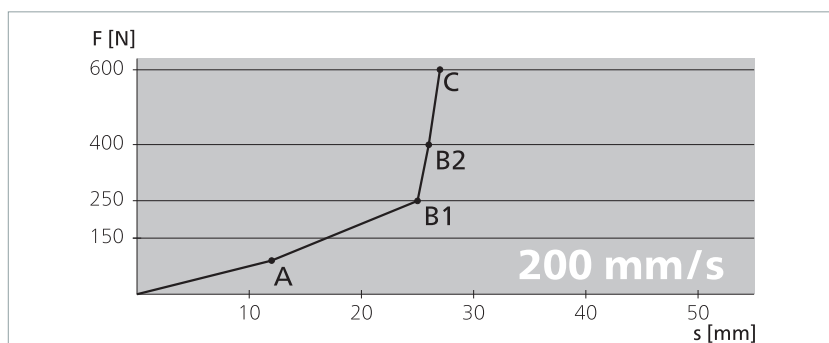

Technical data

GP 48-2 EPDM with C 26

Normally closed safety edge SL NC II consisting of sensor and aluminium profile from the profile range C 26.

Testing basis	
ISO 13856-2	
Switching characteristics at $v_{\text{test}} = 100 \text{ mm/s}$	
Switching operations	>10,000
Actuation force	
Test piece (cylinder) Ø 80 mm	< 150 N
Actuation distance	
Test piece (cylinder) Ø 80 mm	14.8 mm
Actuation angle	
Test piece (cylinder) Ø 80 mm	90°
Response time	148 ms
Finger detection	no
Safety classifications	
ISO 13856: Reset function	without
ISO 13849-1:2015	Category 3 PL d
B_{10D} (Sensor)	2×10^6
Mechanical operating conditions	
Sensor length (min./max.)	30 cm / 6 m
Cable length (min./max.)	1.5 m / 100 m
Bend radii	not possible
Operating speed	
(min. / max.)	10 mm/s / 200 mm/s
max. load capacity	600 N
IEC 60529: Degree of protection	IP67
Humidity (max. at 23 °C)	95 % (non-condensing)
Operating temperature	-10 to +55 °C
Storage temperature	-20 to +80 °C
Weight	1.0 kg/m
Electrical operating conditions	
Contact transition resistance (max.)	5 Ohm
Number of sensors type BK	max. 10 in series
Switching voltage (PELV) (max.)	48 V DC
	48 V AC 50/60 Hz
Protection class	III
Switching current (max.)	20 mA
Contact fuse protection, external	250 mA slow-acting
Connection cable	Ø 3.3 mm PVC 1x 0.5 mm ²

Dimensions and distances

GP 48-2 EPDM (1:2)

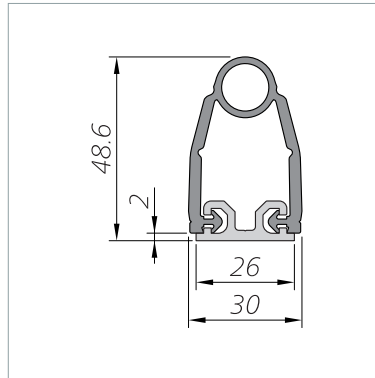

Dimensional tolerances according to ISO 3302 E2/L2.

Test conditions

according to ISO 13856-2

- Installation position B
- Temperature +20 °C
- Measurement point c3
- Test sample 1 with Ø 80 mm
- without control unit

Force-distance ratios

Actuation force	86 N
Response time	1440 ms
Actuation distance (A)	14.4 mm
Overtravel distance	
up to 250 N (B1)	11.3 mm
up to 400 N (B2)	12.3 mm
up to 600 N (C)	13.2 mm
Total deformation	27.1 mm

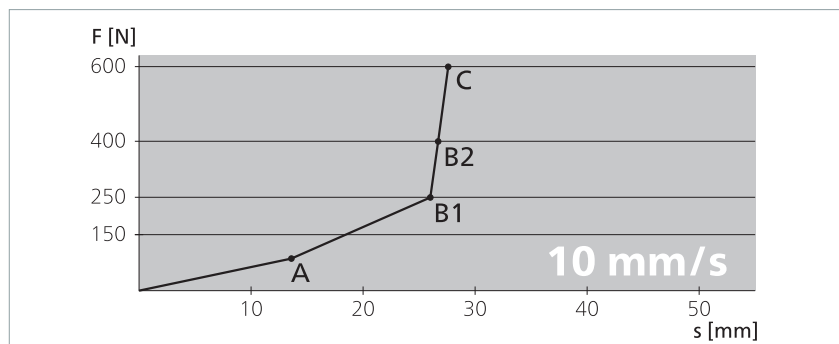

Actuation force	95 N
Response time	148 ms
Actuation distance (A)	14.8 mm
Overtravel distance	
up to 250 N (B1)	10.8 mm
up to 400 N (B2)	11.6 mm
up to 600 N (C)	12.6 mm
Total deformation	26.9 mm

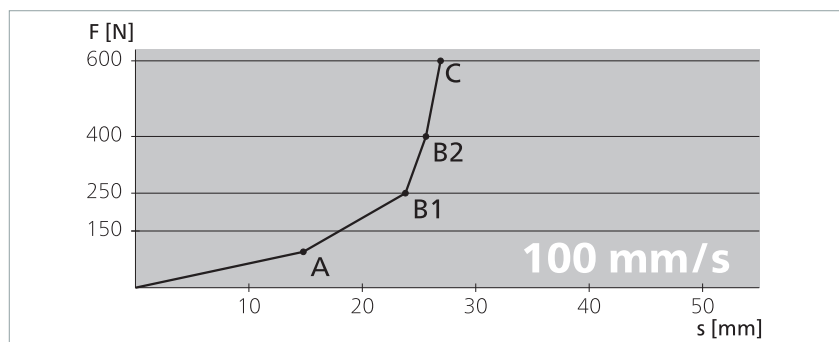

Technical data

GP 65-2 EPDM with C 36

Normally closed safety edge SL NC II consisting of sensor and aluminium profile from the profile range C 36.

Testing basis	
ISO 13856-2	
Switching characteristics at $v_{\text{test}} = 200 \text{ mm/s}$	
Switching operations	>10,000
Actuation force	
Test piece (cylinder) Ø 80 mm	< 150 N
Actuation distance	
Test piece (cylinder) Ø 80 mm	7 mm
Actuation angle	
Test piece (cylinder) Ø 80 mm	90°
Response time	35 ms
Finger detection	no
Safety classifications	
ISO 13856: Reset function	without
ISO 13849-1:2015	Category 3 PL d
B_{10D} (Sensor)	2×10^6
Mechanical operating conditions	
Sensor length (min./max.)	30 cm / 6 m
Cable length (min./max.)	1.5 m / 100 m
Bend radii	not possible
Operating speed	
(min. / max.)	10 mm/s / 200 mm/s
max. load capacity	600 N
IEC 60529: Degree of protection	IP67
Humidity (max. at 23 °C)	95 % (non-condensing)
Operating temperature	-10 to +55 °C
Storage temperature	-20 to +80 °C
Weight	1.9 kg/m
Electrical operating conditions	
Contact transition resistance (max.)	5 Ohm
Number of sensors type BK	max. 10 in series
Switching voltage (PELV) (max.)	48 V DC
	48 V AC 50/60 Hz
Protection class	III
Switching current (max.)	20 mA
Contact fuse protection, external	250 mA slow-acting
Connection cable	Ø 3.3 mm PVC 1x 0.5 mm ²

Dimensions and distances

GP 65-2 EPDM (1:2)

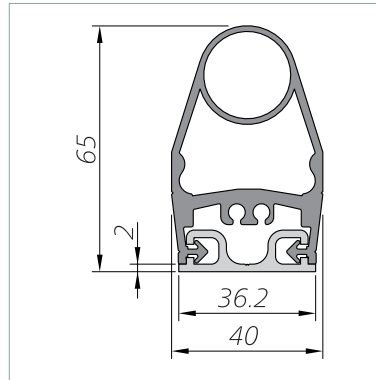

Dimensional tolerances according to ISO 3302 E2/L2.

Test conditions

according to ISO 13856-2

- Installation position B
- Temperature +20 °C
- Measurement point c3
- Test sample 1 with Ø 80 mm
- without control unit

All data stated here is documented in EC design type test certificates.

Force-distance ratios

Actuation force	69 N
Response time	890 ms
Actuation distance (A)	8.9 mm
Overtravel distance	
up to 250 N (B1)	15.6 mm
up to 400 N (B2)	17.5 mm
up to 600 N (C)	19.3 mm
Total deformation	28.2 mm

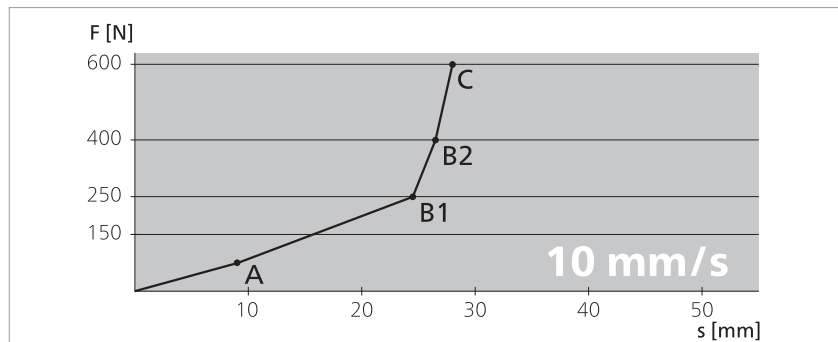

Actuation force	71 N
Response time	80 ms
Actuation distance (A)	8 mm
Overtravel distance	
up to 250 N (B1)	15.5 mm
up to 400 N (B2)	17.3 mm
up to 600 N (C)	19.1 mm
Total deformation	27.1 mm

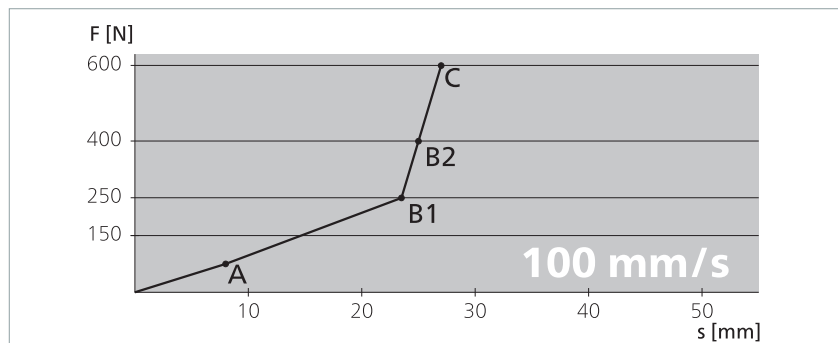

Actuation force	64 N
Response time	34.5 ms
Actuation distance (A)	6.9 mm
Overtravel distance	
up to 250 N (B1)	16.5 mm
up to 400 N (B2)	18.5 mm
up to 600 N (C)	20 mm
Total deformation	26.9 mm

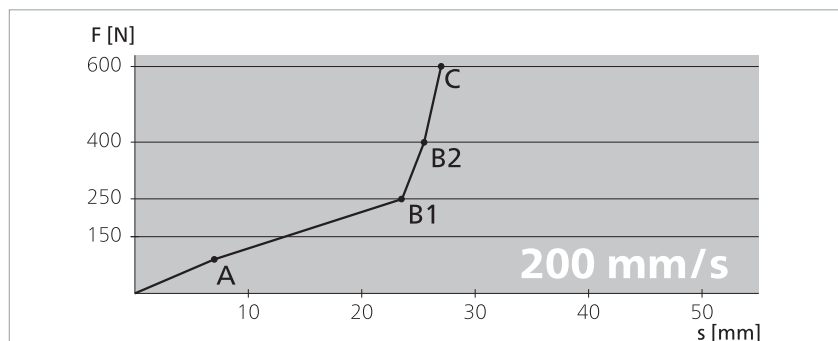

Technical data

GP 100-2 EPDM with C 36

Normally closed safety edge SL NC II consisting of sensor and aluminium profile from the profile range C 36.

Testing basis	
ISO 13856-2	
Switching characteristics at $v_{\text{test}} = 200 \text{ mm/s}$	
Switching operations	>10,000
Actuation force	
Test piece (cylinder) Ø 80 mm	< 150 N
Actuation distance	
Test piece (cylinder) Ø 80 mm	17 mm
Actuation angle	
Test piece (cylinder) Ø 80 mm	90°
Response time	82 ms
Finger detection	no
Safety classifications	
ISO 13856: Reset function	without
ISO 13849-1:2015	Category 3 PL d
B_{10D} (Sensor)	2×10^6
Mechanical operating conditions	
Sensor length (min./max.)	30 cm / 6 m
Cable length (min./max.)	1.5 m / 100 m
Bend radii	not possible
Operating speed	
(min. / max.)	10 mm/s / 200 mm/s
max. load capacity	600 N
IEC 60529: Degree of protection	IP67
Humidity (max. at 23 °C)	95 % (non-condensing)
Operating temperature	-10 to +55 °C
Storage temperature	-20 to +80 °C
Weight	2.1 kg/m
Electrical operating conditions	
Contact transition resistance (max.)	5 Ohm
Number of sensors type BK	max. 10 in series
Switching voltage (PELV) (max.)	48 V DC
	48 V AC 50/60 Hz
Protection class	III
Switching current (max.)	20 mA
Contact fuse protection, external	250 mA slow-acting
Connection cable	Ø 3.3 mm PVC 1x 0.5 mm ²

Dimensions and distances

GP 100-2 EPDM (1:3)

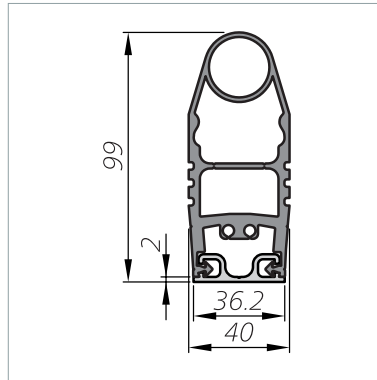

Dimensional tolerances according to ISO 3302 E2/L2.

Test conditions

according to ISO 13856-2

- Installation position B
- Temperature +20 °C
- Measurement point c3
- Test sample 1 with Ø 80 mm
- without control unit

All data stated here is documented in EC design type test certificates.

Force-distance ratios

Actuation force	73 N
Response time	1410 ms
Actuation distance (A)	14.1 mm
Overtravel distance	
up to 250 N (B1)	34.3 mm
up to 400 N (B2)	37.5 mm
up to 600 N (C)	41.1 mm
Total deformation	55.2 mm

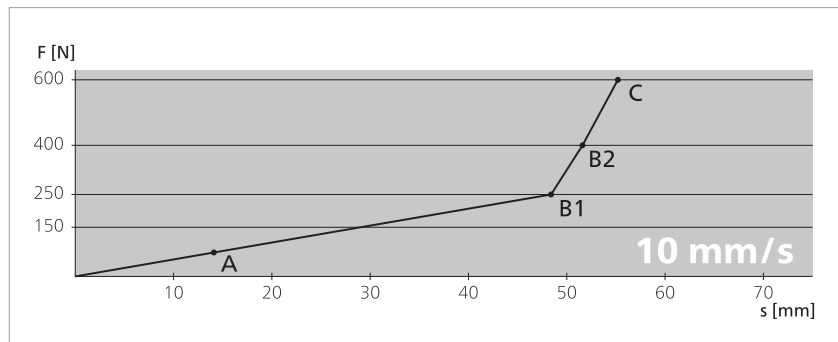

Actuation force	56 N
Response time	76 ms
Actuation distance (A)	7.6 mm
Overtravel distance	
up to 250 N (B1)	36.8 mm
up to 400 N (B2)	40.4 mm
up to 600 N (C)	43.7 mm
Total deformation	51.3 mm

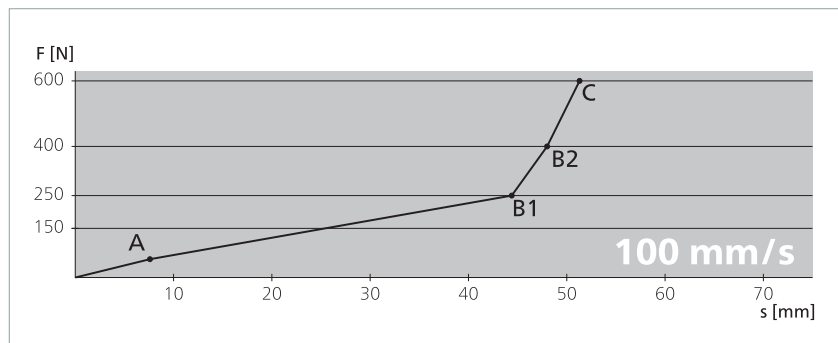

Actuation force	68 N
Response time	82 ms
Actuation distance (A)	16.4 mm
Overtravel distance	
up to 250 N (B1)	29.4 mm
up to 400 N (B2)	32.8 mm
up to 600 N (C)	35.7 mm
Total deformation	52.1 mm

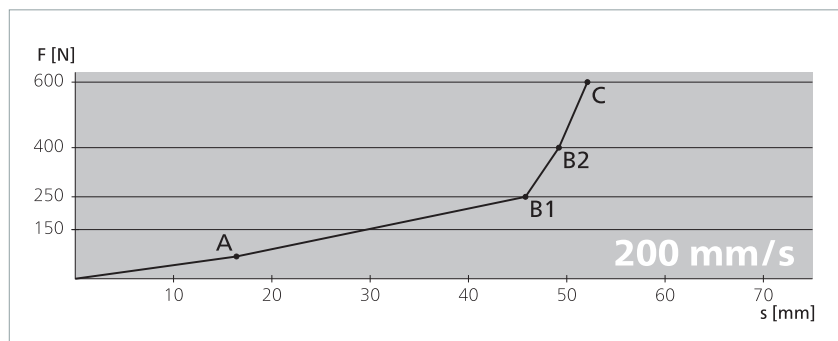

Conformity

Conformity

The CE symbol indicates that this Mayser product complies with the relevant EC directives and that the stipulated conformity assessments have been carried out.



The design type of the product complies with the basic requirements of the following directives:

- 2006/42/EC (Safety of machinery)
- 2014/30/EU (EMC)

The Declaration of Conformity is available in the download section of the website: www.mayser.com/en/downloads

EC design test

The product was tested by an independent institute.

An EC design type test certificate confirms conformity.

The EC design type test certificate is available in the download section of the website: www.mayser.com/en/downloads

UL certification

Certificates

UL certification

U8V 07 10 31146 006

