

Selection diagram

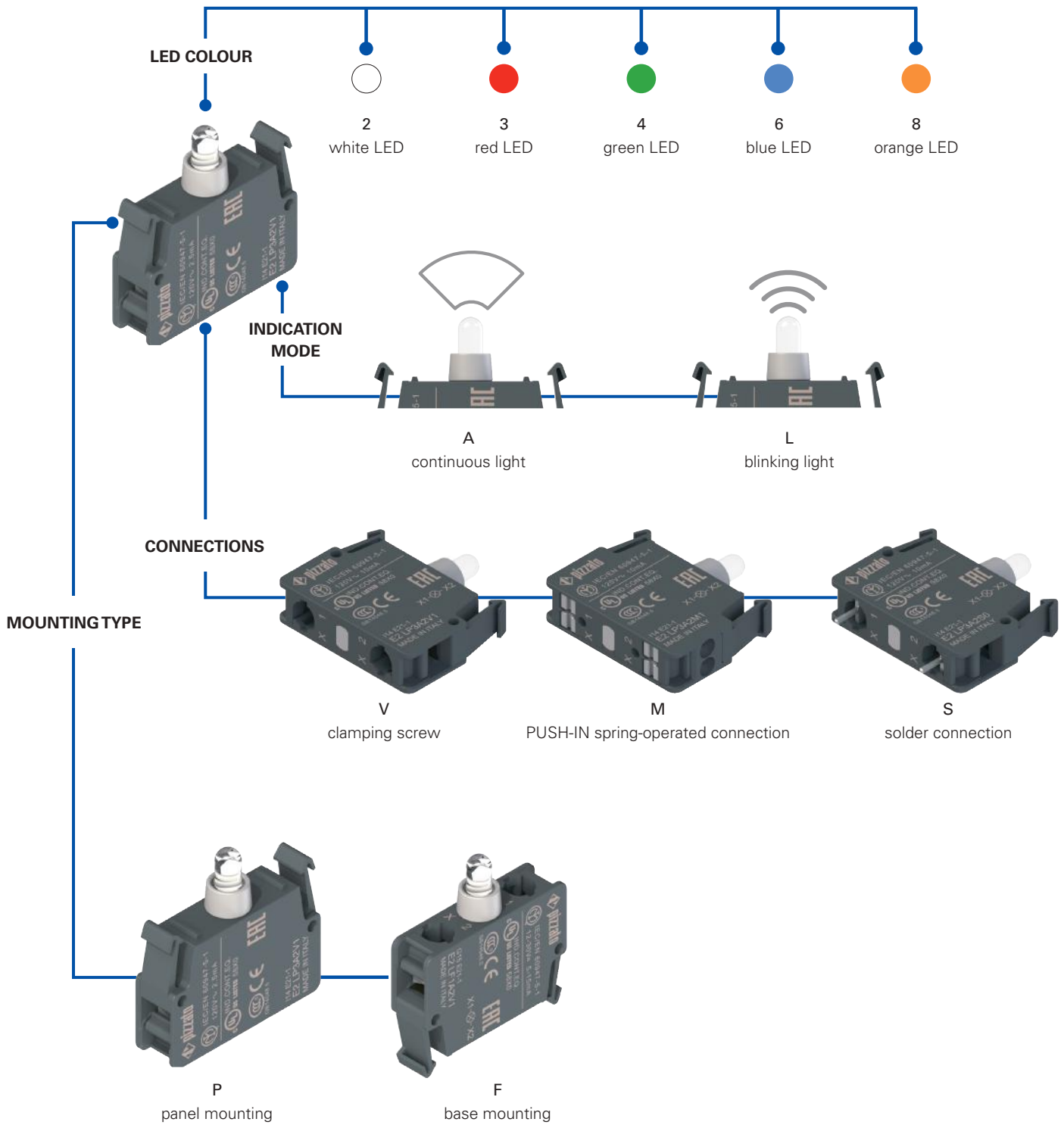

Code structure **Attention!** The feasibility of a code number does not mean the effective availability of a product. Please contact our sales office.

E2 LP1A3V1

Mounting type	
P	panel mounting
F	base mounting

Protection degree	
0	IP00 solder connection
1	IP20 screw connection and PUSH-IN spring-operated connection

Supply voltage	
1	12 ... 30 Vac/dc (high luminosity)
3	120 Vac (high luminosity)
4	230 Vac (high luminosity)
7	120 Vac/dc (standard luminosity)
8	230 Vac/dc (standard luminosity)

Connection type	
V	clamping screw (standard)
M	PUSH-IN spring-operated connection
S	solder connection (panel mounting only)

Indication mode	
A	Continuous light (standard)
L	blinking light (12 ... 30 V power supply only)

LED colour	
2	white
3	red
4	green
6	blue
8	orange

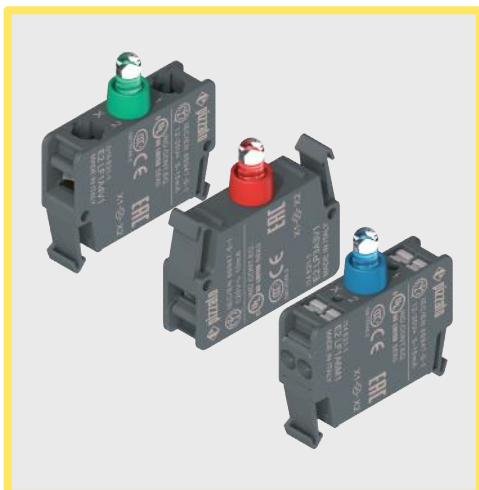

Main features

- High luminosity LED
- Three supply voltages:
 - 12 ... 30 Vac/dc, 120 Vac, 230 Vac
- Screw, PUSH-IN spring, or solder connections.
- Continuous or blinking light
- Panel and base mounting versions

Quality marks:



IMQ approval:	CA02.04806
UL approval:	E131787
CCC approval:	2013010305631156
EAC approval:	RU C-IT.AQ35.B.00454

Technical data

General data

Protection degree acc. to EN 60529:	IP20 with screw connection IP20 with PUSH-IN spring-operated connection IP00 with solder connection
Ambient temperature:	-25°C ... +70°C
Endurance:	100,000 hours (at rated voltage and +25 °C ambient temperature)
Utilization requirements:	see page 149

LED unit

Operating voltages and currents (high luminosity versions):	12 ... 30 Vac/dc; 5 ... 20 mA 102 ... 138 Vac; 20 mA max 195 ... 264 Vac; 20 mA max
Operating voltages and currents (standard luminosity versions):	102 ... 138 Vac/dc; 2.5 mA 195 ... 264 Vac/dc; 2.5 mA
Blinking frequency:	1 Hz

Clamping screw connection

Cable cross section:	min 1 x 0.5 mm ² (1 x AWG 20) max 2 x 2.5 mm ² (2 x AWG 14)
Tightening torque:	0.6 ... 0.8 Nm
Cable stripping length (x):	8 mm

PUSH-IN spring-operated connection

Cable cross section (flexible conductors, with or without wire-end sleeve):	min. 1 x 0.25 mm ² (1 x AWG 24) max. 2 x 1.5 mm ² (1 x AWG 16)
Cable stripping length (x):	min. 8 mm, max. 10 mm



In compliance with standards:

IEC 60947-1, IEC 60947-5-1, IEC 60204-1, EN 60947-1, EN 60947-5-1, EN 60204-1, EN 50581, UL 508, CSA 22-2 N°14.

Compliance with the requirements of:

Low Voltage Directive 2014/35/EU,
EMC Directive 2014/30/EU,
RoHS Directive 2011/65/EU.

Features approved by UL

Electrical ratings:
12-30 V ac/dc, 5-20 mA
120 V ac, 20 mA max
230 V ac, 20 mA max
120 V ac/dc, 2.5 mA
230 V ac/dc, 2.5 mA

Note:
Use 60 or 75 °C copper (CU) conductor and wire size range 12-20 AWG, stranded or solid.
The terminal tightening torque of 7.1 Lb In (0.8 Nm).

Please contact our technical department for the list of approved products.

Features approved by IMQ

Rated insulation voltage (Ui): 500 V
Indicator light type: Incorporated LED
Terminals: screw terminals
Rated operating voltage (Ue):
12 ... 30 Vac/dc (5 ... 20 mA), 120 Vac (20 mA), 230 Vac (20 mA)

In compliance with standards: EN 60947-1, EN 60947-5-1:2004 + A1:2009, fundamental requirements of the Low Voltage Directive 2014/35/EU.

Please contact our technical department for the list of approved products.

General data

Continuous or blinking light



The LED units can be provided with two different lighting types: continuous or blinking light. The blinking light versions allow a faster identification on the panel of the lit device compared to the continuous light. The special internal electronic circuit autonomously alternates the ON and OFF phases without requiring any special electrical connection.

Screw connection with clamping screw plates

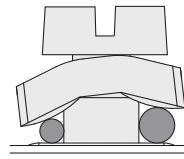

The clamping screw plates of the LED units are provided with a particular "roofing tile" structure and are loosely coupled to the clamping screw. This way, during the wires fixing, the clamping screw plate is able to suit to cables of different diameters and tends to tighten the wires toward the screw instead of permitting them to escape towards the outside.

PUSH-IN spring-operated connection



The PUSH-IN spring connection allows quick and simple wiring, as the wire just needs to be inserted into the appropriate hole in order to establish the electrical connection and automatically secure the wire. The reduced force required to insert the wire allows completely tool-free connection by using wires with crimped wire-end sleeves. They are released by pressing a special wire release button - including individually - with any tool, without the need to use a screwdriver of a predefined size. In addition, the contact block has holes for insertion of tester tips, so that electrical measurements can be carried out, without having to remove the connecting cables.

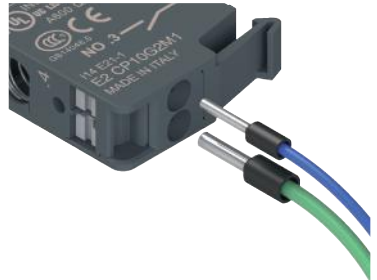

Solder connection on printed circuit

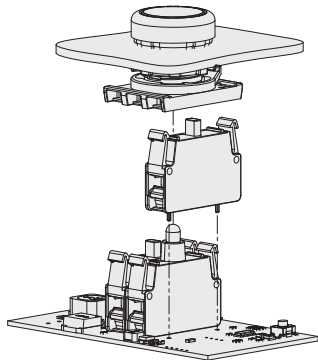

Versions with panel mounting of the EROUND series LED units with solder pin are available. If there is no wiring but a printed circuit, these LED units can be directly welded on the latter.

Available versions

The LED units of the signalling and control devices are available with two types of coupling: panel mounting and base mounting.

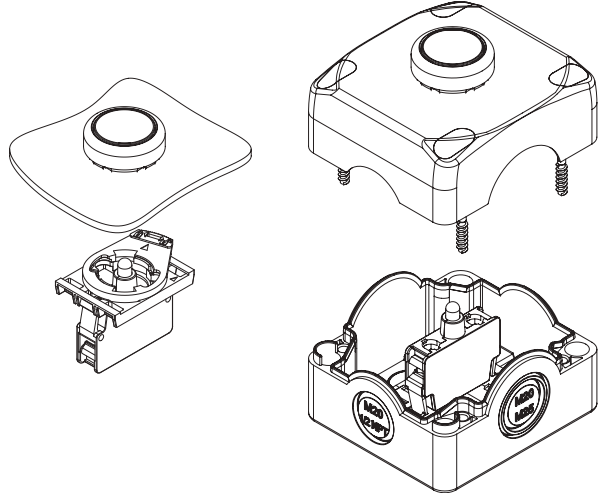

High luminosity LED

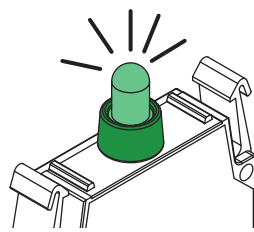

The LED units to combine with the luminous devices feature a high-intensity LED, which ensures greater visibility. The use of an integrated LED gives greater benefits compared to incandescence lamps because they last longer and absorb less power than the latter. LEDs feature greater reliability, low consumption, and high resistance to vibrations.

Selection table for LED units

Packs of 5 pcs.



LED colour	Actuator colour	Panel mounting								
		Screw connection			PUSH-IN spring-operated connection			Solder connection		
		Operating voltage								
		12 ... 30 Vac/dc	120 Vac	230 Vac	12 ... 30 Vac/dc	120 Vac	230 Vac	12 ... 30 Vac/dc	120 Vac	230 Vac
white	white / yellow	E2 LP1A2V1	E2 LP3A2V1	E2 LP4A2V1	E2 LP1A2M1	E2 LP3A2M1	E2 LP4A2M1	E2 LP1A2S0	E2 LP3A2S0	E2 LP4A2S0
red	red	E2 LP1A3V1	E2 LP3A3V1	E2 LP4A3V1	E2 LP1A3M1	E2 LP3A3M1	E2 LP4A3M1	E2 LP1A3S0	E2 LP3A3S0	E2 LP4A3S0
green	green	E2 LP1A4V1	E2 LP3A4V1	E2 LP4A4V1	E2 LP1A4M1	E2 LP3A4M1	E2 LP4A4M1	E2 LP1A4S0	E2 LP3A4S0	E2 LP4A4S0
blue	blue	E2 LP1A6V1	E2 LP3A6V1	E2 LP4A6V1	E2 LP1A6M1	E2 LP3A6M1	E2 LP4A6M1	E2 LP1A6S0	E2 LP3A6S0	E2 LP4A6S0
orange	orange	E2 LP1A8V1	E2 LP3A8V1	E2 LP4A8V1	E2 LP1A8M1	E2 LP3A8M1	E2 LP4A8M1	E2 LP1A8S0	E2 LP3A8S0	E2 LP4A8S0

We recommend to match the colour combination of the LEDs with the actuator colours.













LED colour	Actuator colour	Base mounting					
		Screw connection			PUSH-IN spring-operated connection		
		Operating voltage					
		12 ... 30 Vac/dc	120 Vac	230 Vac	12 ... 30 Vac/dc	120 Vac	230 Vac
white	white / yellow	E2 LF1A2V1	E2 LF3A2V1	E2 LF4A2V1	E2 LF1A2M1	E2 LF3A2M1	E2 LF4A2M1
red	red	E2 LF1A3V1	E2 LF3A3V1	E2 LF4A3V1	E2 LF1A3M1	E2 LF3A3M1	E2 LF4A3M1
green	green	E2 LF1A4V1	E2 LF3A4V1	E2 LF4A4V1	E2 LF1A4M1	E2 LF3A4M1	E2 LF4A4M1
blue	blue	E2 LF1A6V1	E2 LF3A6V1	E2 LF4A6V1	E2 LF1A6M1	E2 LF3A6M1	E2 LF4A6M1
orange	orange	E2 LF1A8V1	E2 LF3A8V1	E2 LF4A8V1	E2 LF1A8M1	E2 LF3A8M1	E2 LF4A8M1





We recommend to match the colour combination of the LEDs with the actuator colours.

Complete units with LED unit, contact block and mounting adapter













LED colour	Contacts			Panel mounting	
	pos. 2	pos. 3	pos. 1	Operating voltage 12 ... 30 Vac/dc	
 white	1NC 	LED	-	E2 AC-XXBC0020 E2 1BAC11 + E2 CP01G2V1 + E2 LP1A2V1	
 red	1NC 	LED	-	E2 AC-XXBC0037 E2 1BAC11 + E2 CP01G2V1 + E2 LP1A3V1	
 green	1NC 	LED	-	E2 AC-XXBC0029 E2 1BAC11 + E2 CP01G2V1 + E2 LP1A4V1	
 blue	1NC 	LED	-	E2 AC-XXBC0045 E2 1BAC11 + E2 CP01G2V1 + E2 LP1A6V1	
 orange	1NC 	LED	-	E2 AC-XXBC0058 E2 1BAC11 + E2 CP01G2V1 + E2 LP1A8V1	

Other combinations on request.

LED colour	Contacts			Panel mounting	
	pos. 2	pos. 3	pos. 1	Operating voltage 12 ... 30 Vac/dc	
 white	-	LED	1NO	E2 AC-XXBC0021 E2 1BAC11 + E2 LP1A2V1 + E2 CP10G2V1	
 red	-	LED	1NO	E2 AC-XXBC0039 E2 1BAC11 + E2 LP1A3V1 + E2 CP10G2V1	
 green	-	LED	1NO	E2 AC-XXBC0031 E2 1BAC11 + E2 LP1A4V1 + E2 CP10G2V1	
 blue	-	LED	1NO	E2 AC-XXBC0047 E2 1BAC11 + E2 LP1A6V1 + E2 CP10G2V1	
 orange	-	LED	1NO	E2 AC-XXBC0059 E2 1BAC11 + E2 LP1A8V1 + E2 CP10G2V1	

Other combinations on request.



LED colour	Contacts			Panel mounting	
	pos. 2	pos. 3	pos. 1	Operating voltage 12 ... 30 Vac/dc	
 white	1NC 	LED	1NO	E2 AC-XXBC0027 E2 1BAC11 + E2 CP01G2V1 + E2 LP1A2V1 + E2 CP10G2V1	
 red	1NC 	LED	1NO	E2 AC-XXBC0044 E2 1BAC11 + E2 CP01G2V1 + E2 LP1A3V1 + E2 CP10G2V1	
 green	1NC 	LED	1NO	E2 AC-XXBC0036 E2 1BAC11 + E2 CP01G2V1 + E2 LP1A4V1 + E2 CP10G2V1	
 blue	1NC 	LED	1NO	E2 AC-XXBC0052 E2 1BAC11 + E2 CP01G2V1 + E2 LP1A6V1 + E2 CP10G2V1	
 orange	1NC 	LED	1NO	E2 AC-XXBC0060 E2 1BAC11 + E2 CP01G2V1 + E2 LP1A8V1 + E2 CP10G2V1	

Other combinations on request.

LED colour	LED			Panel mounting	
	pos. 2	pos. 3	pos. 1	Operating voltage 12 ... 30 Vac/dc	
 white	-	LED	-	E2 AC-XXBC0053 E2 1BAC11 + E2 LP1A2V1	
 red	-	LED	-	E2 AC-XXBC0055 E2 1BAC11 + E2 LP1A3V1	
 green	-	LED	-	E2 AC-XXBC0054 E2 1BAC11 + E2 LP1A4V1	
 blue	-	LED	-	E2 AC-XXBC0056 E2 1BAC11 + E2 LP1A6V1	
 orange	-	LED	-	E2 AC-XXBC0057 E2 1BAC11 + E2 LP1A8V1	

Other combinations on request.

Dimensions

All values in the drawings are in mm

LED units for panel mounting with screw connection, PUSH-IN spring-operated connection

LED units for base mounting with screw connection, PUSH-IN spring-operated connection

LED units for panel mounting with solder connection

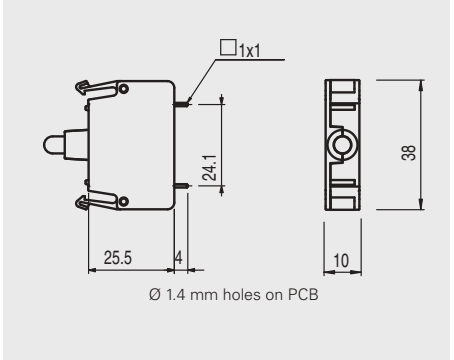
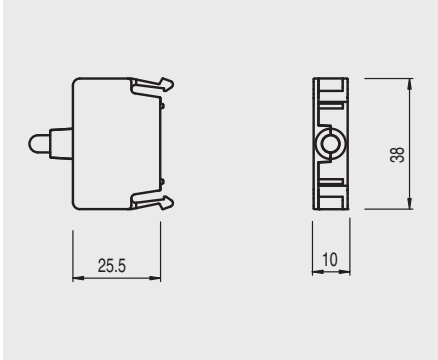
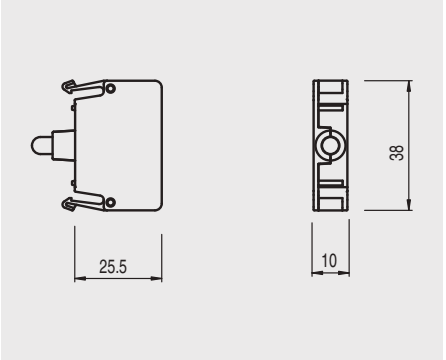

→ The 2D and 3D files are available at www.pizzato.com