

DuraMON

DuraMON15

DuraMON19

DuraMON22

DuraMON24

DuraMON26

DuraMON27

User Reference Manual



Disclaimer

ISIC A/S makes no representation or warranties with respect to the contents or use of this manual, and specifically disclaims any express or implied warranties of merchantability or fitness for any particular purpose. Further, ISIC A/S reserves the right to revise this publication and to make changes to its content at any time, without obligation to notify any person or entity of such revisions or changes.

Image sticking: If the monitor is operated with static images (logo's etc.) it will inevitably lead to images sticking on the display. This is not a permanently situation and can be removed by operating the monitor with a video that is created for this purpose.

FCC Warning

Computing devices and peripherals generate and radiate radio frequency energy, and if not installed and used in accordance with the instructions advised by ISIC A/S, it may cause interference to radio communication.

The DuraMON series, manufactured by ISIC A/S, is designed to comply with the emerging generic EEC standards, that cover applications in maritime environment.

Classification

The monitor is classified as "protected from the weather" according to IEC 60945 ed.4 (former class b).

Approvals

Approval according to IACS E10 ed. 6 and IEC 60945 ed. 4, Maritime navigation and radio communication equipment and systems – General requirements.

ECDIS IEC 61174 ed. 4 (Not available on 15" & 22")

Radar IEC 62288 ed. 2

Radar IEC 62388 ed. 2



ISIC A/S is complying with the WEEE directive within the European Union, stating that electronic and electric products must be collected separately.

Products are marked according to the directive.

Copyright 2018 ISIC A/S

ISIC A/S
Edwin Rahrs Vej 54
DK-8220 Brabrand
Denmark

Phone: +45 70 20 70 77
Fax: +45 70 20 79 76
Web: <http://www.isic-systems.com>



Table of Contents

1	FEATURES	5
2	GENERAL CONSIDERATIONS ON INSTALLATION AND OPERATION	6
3	DURAMON CONNECTIONS	7
3.1	DURAMON 15”.....	7
3.2	DURAMON 19”.....	7
3.3	DURAMON 22”.....	7
3.4	DURAMON 24”.....	8
3.5	DURAMON 26”.....	8
3.6	DURAMON 27”.....	8
4	DURAMON FRONT PANEL CONTROLS	9
5	SERIAL CONNECTION PIN-OUT	10
6	TECHNICAL SPECIFICATIONS DURAMON	10
6.1	SPECIFICATION DURAMON 15”	11
6.2	SPECIFICATION DURAMON 19”	11
6.3	SPECIFICATION DURAMON 22”	11
6.4	SPECIFICATION DURAMON 24”	12
6.5	SPECIFICATION DURAMON 26”	12
6.6	SPECIFICATION DURAMON 27”	12
6.7	MECHANICAL OUTLINE DURAMON 15”.....	13
6.8	MECHANICAL OUTLINE DURAMON 19”.....	14
6.9	MECHANICAL OUTLINE DURAMON 22”.....	15
6.10	MECHANICAL OUTLINE DURAMON 24”.....	16
6.11	MECHANICAL OUTLINE DURAMON 26”.....	17
6.12	MECHANICAL OUTLINE DURAMON 27”.....	18
7	TOUCH SCREEN OPTION (19” ONLY)	19
8	ECDIS MODE	21
9	DURA SERIAL COMMUNICATION PROTOCOL	21
10	COMPASS SAFE DISTANCE	21
11	POWER CONSUMPTION	22
12	INRUSH CURRENT	22
13	POPUP MENU	23
13.1	ADVANCED OSD	23
13.2	INPUT SELECT	23
13.3	VGA ADJUSTMENTS.....	24
13.4	COLOR ADJUSTMENTS (NOT AVAILABLE IN ECDIS MODE)	25
13.5	ADVANCED COLOR (NOT AVAILABLE IN ECDIS MODE)	27
13.6	OSD SETTINGS	28
13.7	SYSTEM SETTINGS	29
15	TROUBLESHOOTING	30
16	SERVICING THE UNIT	30
17	TERMS, ACRONYMS AND ABBREVIATIONS	30
18	ISIC INFO / SUPPORT	31



19 REVISION HISTORY 32
20 APPENDIX A: PIXEL POLICY 33



1 Features

Congratulations on your purchase of a DuraMON. This short form manual is designed to get you started working with your new DuraMON.

The DuraMON series of monitors are all made as rugged monitors especially designed for the demanding operating conditions at sea.

The DuraMON series are tested for full compliance to marine-standards IACS E10 and IEC 60945. The monitor comes with excellent brightness and contrast levels that, together with wide viewing angles, ensure a good readability thus making it very eye-friendly. For the best picture quality, always use a double shielded cable with ferrites, like the one supplied with the monitor.

Direct dimming control (1cd to 100%) from UP/DOWN buttons.
Full settings control via menu or serial link.
Support for DDC
Anti-Reflective coated glass.
IP65 protected front.

Multiple connections to cover the widest range of signal sources:
Display Port / HDMI
DVI-D
VGA

Resistant to most chemicals

Optional Touch Screen available, but has to be ordered with the monitor (not part of the IEC 60945 approval).



2 General considerations on Installation and Operation

The DuraMON is designed to work at conditions according to IEC 60945. However, keeping the temperature and vibration level at a minimum will extend the life time of the product. ISIC recommend operating this product at normal room temperature (20-25 °C), with the lowest level of vibration and humidity.

Installation of the DuraMON

In order to obtain the best possible operating conditions, please note the following precautions.

- Room for cooling.
When designing the cabinet/console for the DuraMON, please ensure that air can flow freely around the cabinet, in order to avoid any unnecessary rise in temperature. If it is not possible to have an adequate natural airflow, use a fan to force the airflow to be higher.
- Mounting positions
To obtain adequate cooling by convection ISIC recommends that the DuraMON is mounted at least 30 degrees from horizontal. If this is not possible, forced cooling must be applied directly to the unit in order not to overheat it.
- Sunlight
If the unit can be exposed to direct sunlight, there is a potential risk that the unit can be overheated. Please take measures to prevent direct sunlight. Do also consider forced cooling on the back of the unit.

Operation of the DuraMON

To ensure that colors and luminance on the display are correct in ECDIS applications, do not use the monitor until the warm-up period has completed.

The warm-up period is as follows:

	Day mode	Dusk mode	Night mode
DuraMON19	30 min	30 min	30 min
DuraMON24	30 min	30 min	30 min
DuraMON26	30 min	30 min	30 min
DuraMON27	30 min	30 min	30 min



3 DuraMON connections

Below is a view of optional connections to the monitor. The default inputs are: power, RS-232, DP/HDMI, DVI and VGA.

3.1 DuraMON 15”:

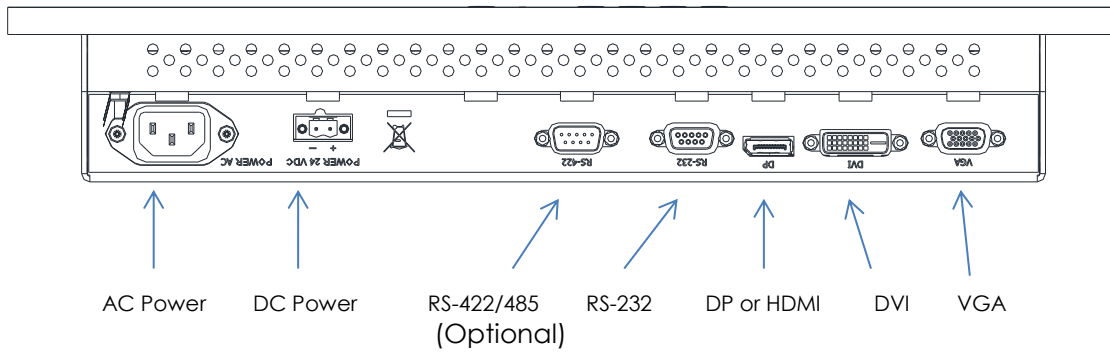

3.2 DuraMON19”:

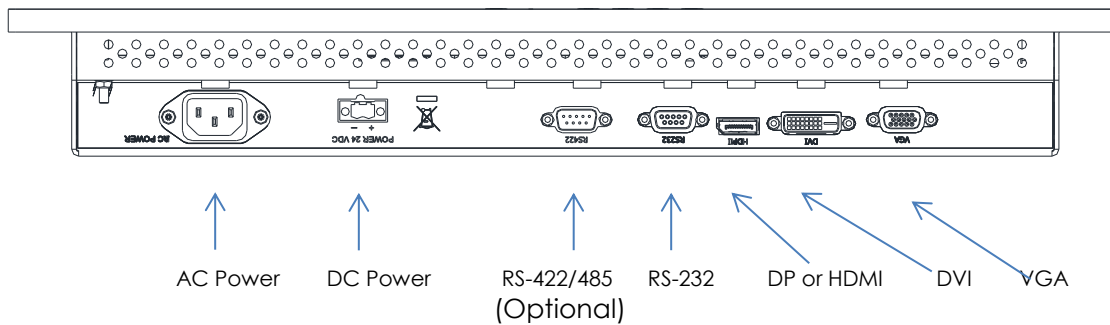

3.3 DuraMON 22”:

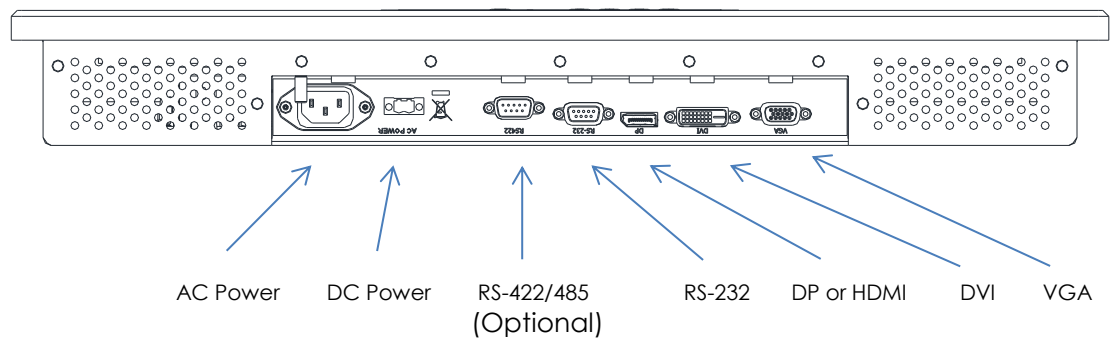

3.4 DuraMON 24”:

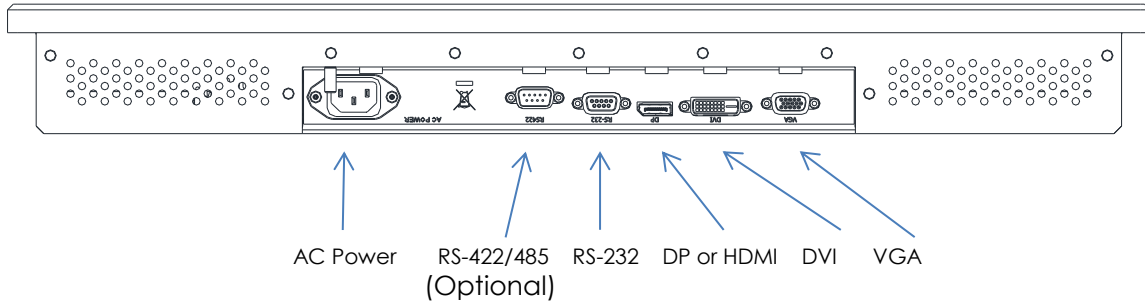

3.5 DuraMON 26”:

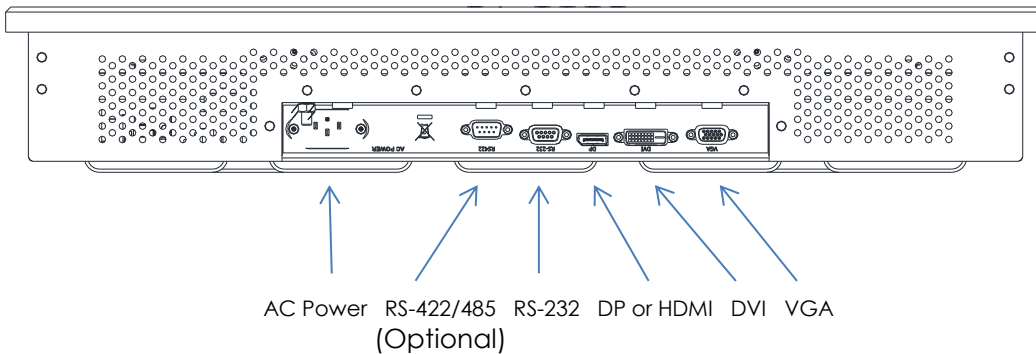

3.6 DuraMON 27”:

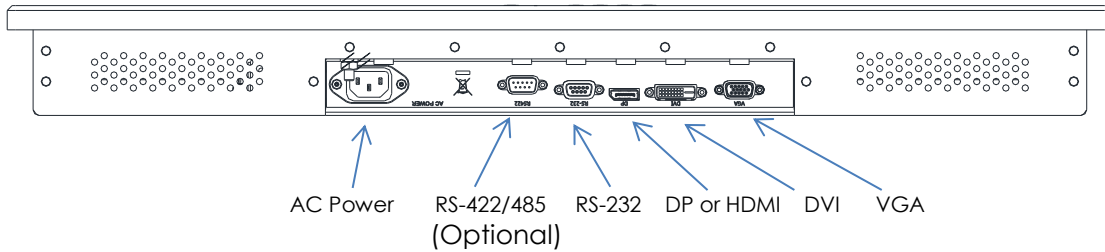

To connect the DC power connector you need a screw driver
Only use multicore cables from AWG16 to AWG12 (1.0 mm² to 4 mm²)
DC connector: Weidmüller, BLZP 5.08HC/02/180F SN BK BX, 1944330000
AC Connector: IEC 60320 type C13

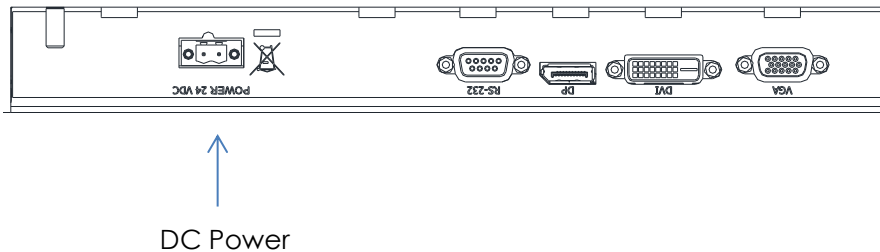

4 DuraMON front panel controls

The front panel is illuminated and will follow the brightness level of the monitor backlight.

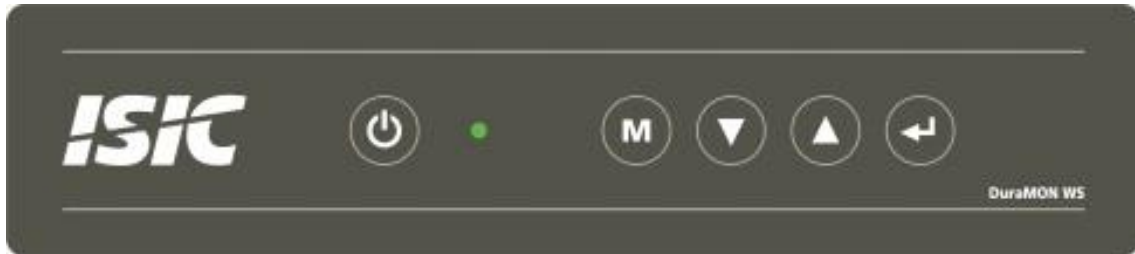

↑ ↑ ↑ ↑ ↑ ↑
On/Off LED Menu Down Up Enter

ON/OFF:

This key is used to turn the product on or off. Pressing it will turn the power on, while holding it pressed for 5 seconds will turn the power off. The light in the button will change from Green to red to indicate it's powered down. It is important to notice that, when powered off, the product still consumes some power from the mains. To cut off the power from the product it is necessary to unplug its power cord from the mains.

If there is no active signal, the monitor will go to suspend mode until an active signal is detected. During suspend mode the status light will blink.

Non ECDIS calibrated monitors:

Monitors: The LED will illuminate Green when the monitor is powered on and red when the monitor is powered down. The LED will be red if no active signal is found.

ECDIS calibrated monitors:

The LED will ONLY illuminate green when the backlight level is at calibrated setting AND ONLY on a calibrated port. If the backlight level isn't at calibrated setting OR an uncalibrated port is used the LED will illuminate orange.

ECDIS calibrated monitors (old units):

The LED will ONLY illuminate orange when the backlight level is at calibrated setting AND ONLY on a calibrated port. If the backlight level isn't at calibrated setting OR an uncalibrated port is used the LED will illuminate green.

Menu:

To activate the OSD menu, press "Menu" and "Enter" buttons at the same time. See Popup Menu section for details.

UP/DOWN:

Used to adjust backlight or to navigate and adjust settings in menus. Pressing UP and DOWN together will restore the backlight level to the last selected ECDIS mode by the serial link. (See document 04924-001 for protocol details).

ENTER:

This key is used to confirm and to enter the advanced OSD by pressing ENTER and thereafter MENU while holding ENTER pressed.



5 Serial connection pin-out

Pin	RS-232	RS-232 (Touch)	RS-422/RS-485 (4 wire)	RS-485 (2 wire)
	SUB-D 9-pol female	SUB-D 9-pol female	SUB-D 9-pol female	SUB-D 9-pol female
1				
2	TX	TX	B (RX-)	B (D-)
3	RX	RX	Y (TX+)	
4				
5	GND	GND	GND	GND
6				
7		RTS	A (RX+)	A (D+)
8		CTS	Z (TX-)	
9				

6 Technical specifications DuraMON

DuraMON I/O

Video inputs:	<p>1 x VGA 1 x DVI-D 1 x Display Port 1.2 / HDMI 1.4a</p> <p>Recommended resolution for: 15" is 1024x768 (4/3) 19" is 1280x1024 (5/4) 22", 24" and 27" is 1920x1080 (16/9) 26" is 1920x1200 (max refresh rate is 60 Hz @ 1920x1200)</p> <p>Generally all VESA compatible video modes are supported. Special modes supported on request.</p>
Control inputs:	<p>1 x RS-232 – for remote control. 1 x RS-422/RS-485 – for remote control / daisy-chain (optional). 1 x USB for touch sensor (optional). For 19" only, 1 x RS232 for touch (optional). 1 x Buzzer, (75-85 dB(A) / 1m) (activated by serial command, only option on 19")</p>

DuraMON Power Supply Options

Standard:	90-264Vac. 50-60Hz Input
Optional:	18-31Vdc Input, (15"/19" is available with both AC and DC simultaneously)

DuraMON Environmental Conditions

Operating Temperature:	-15 to 55 °C
Storage Temperature:	-25 to 70 °C
Relative Humidity:	8 to 90 %

DuraMON Approvals

Marine:	IEC 60945 Ed. 4, 2002-08 & IACS E10 Rev. 6 Oct. 2014
ECDIS, Radar	IEC 61174 ed. 4, IEC 62288 ed. 2, IEC 62388 ed. 2



6.1 Specification DuraMON 15"

Resolution:	1024 × 768
Active Area:	304.1mm x 228.1mm (15.0" diagonal)
Pixel Pitch:	0.297mm x 0.297mm
View angle:	85° (L/R/T/B) (typical)
Luminance:	350 cd/m ² (typical)
Contrast ratio:	1000:1 (typical)
Colours:	16.7 mill. (24-bit)
Response Time:	35 ms (GtG) (typical)
Window:	Anti-Reflective coated front glass
Protection:	IP65 front – IP20 rear
Weight:	4.1 Kg
Dimensions (WxHxD):	406mm x 342mm x 63.9mm

6.2 Specification DuraMON 19"

Resolution:	1280 × 1024
Active Area:	376.320mm x 301.056mm (19.0" diagonal)
Pixel Pitch:	0.294mm x 0.294mm
View angle:	89° (L/R/T/B) (typical)
Viewing distance:	1.02 m
Luminance:	300 cd/m ² (typical)
Contrast ratio:	2000:1 (typical)
Colours:	16.7 mill. (24-bit)
Response Time:	20 ms (GtG) (typical)
Window:	Anti-Reflective coated front glass
Protection:	IP65 front – IP20 rear
Touch:	3M MicroTouch™ ClearTek™ II Capacitive (Optional extra)
Weight:	6.5 Kg
Dimensions (WxHxD):	483mm x 419mm x 63.9mm

6.3 Specification DuraMON 22"

Resolution:	1920 × 1080
Active Area:	476.64mm x 268.11mm (21.53" diagonal)
Pixel Pitch:	0.2482mm x 0.2482mm
View angle:	89° (L/R/T/B) WVA (typical) – 80°/80°/80°/60° (L/R/T/B) TN (typical)
Luminance:	300 cd/m ² WVA - 250 cd/m ² TN (typical)
Contrast ratio:	5000:1 WVA - 1000:1 TN (typical)
Colours:	16.7 mill. (24-bit)
Response Time:	20 ms (GtG) (typical)
Window:	Anti-Reflective coated front glass
Protection:	IP65 front – IP20 rear
Weight:	9 Kg
Dimensions (WxHxD):	552mm x 380mm x 68mm



6.4 Specification DuraMON 24"

Resolution:	1920 × 1080
Active Area:	521.28mm x 293.22mm (23.6" diagonal)
Pixel Pitch:	0.2715mm x 0.2715mm
View angle:	89° (L/R/T/B) (typical)
Viewing distance:	1.00 m
Luminance:	250 cd/m ² (typical)
Contrast ratio:	3000:1 (typical)
Colours:	16.7 mill. (24-bit)
Response Time:	25 ms (GtG) (typical)
Window:	Anti-Reflective coated front glass
Protection:	IP65 front – IP20 rear
Weight:	10 Kg
Dimensions (WxHxD):	599.2mm x 408.3mm x 68mm

6.5 Specification DuraMON 26"

Resolution:	1920 × 1200
Active Area:	550.08mm x 343.8mm (25.54" diagonal)
Pixel Pitch:	0.2865mm x 0.2865mm
View angle:	88° (L/R/T/B) (typical)
Viewing distance:	1.02 m
Luminance:	350 cd/m ² (typical)
Contrast ratio:	1500:1 (typical)
Colours:	16.7 mill. (24-bit)
Response Time:	20 ms (GtG) (typical)
Window:	Anti-Reflective coated front glass
Protection:	IP65 front – IP20 rear
Weight:	12 Kg
Dimensions (WxHxD):	619mm x 463mm x 98.6mm

6.6 Specification DuraMON 27"

Resolution:	1920 × 1080
Active Area:	597.888 mm x 336.312 mm (27" diagonal)
Pixel Pitch:	0.3114mm x 0.3114mm
View angle:	89° (L/R/T/B) (typical)
Viewing distance:	1.08 m
Luminance:	300 cd/m ² (typical)
Contrast ratio:	1000:1 (typical)
Colours:	16.7 mill. (24-bit)
Response Time:	14 ms (GtG) (typical)
Window:	Anti-Reflective coated front glass
Protection:	IP65 front – IP20 rear
Weight:	12 Kg
Dimensions (WxHxD):	683.5mm x 451.6mm x 68mm



6.7 Mechanical outline DuraMON 15"

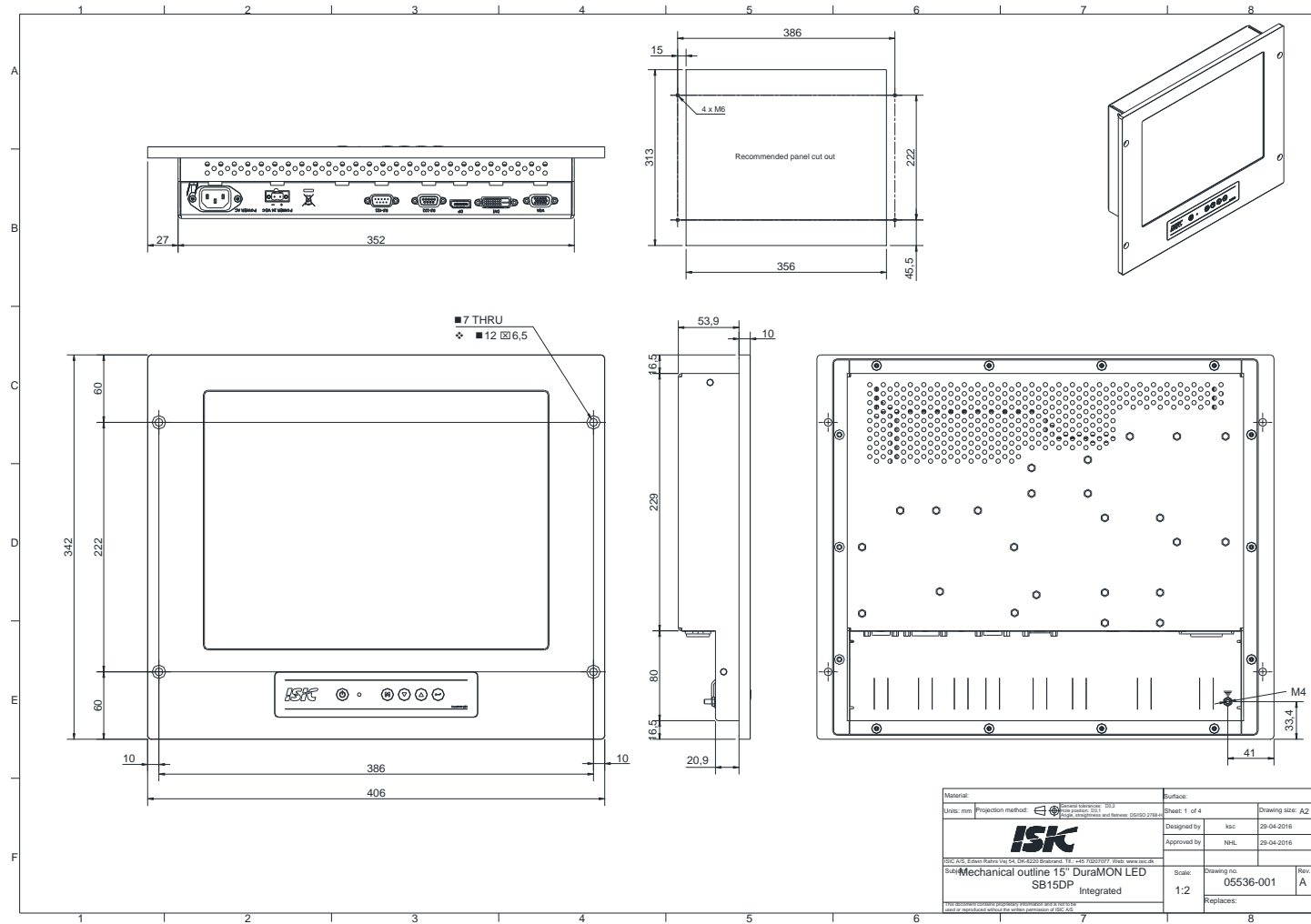

6.8 Mechanical outline DuraMON 19"

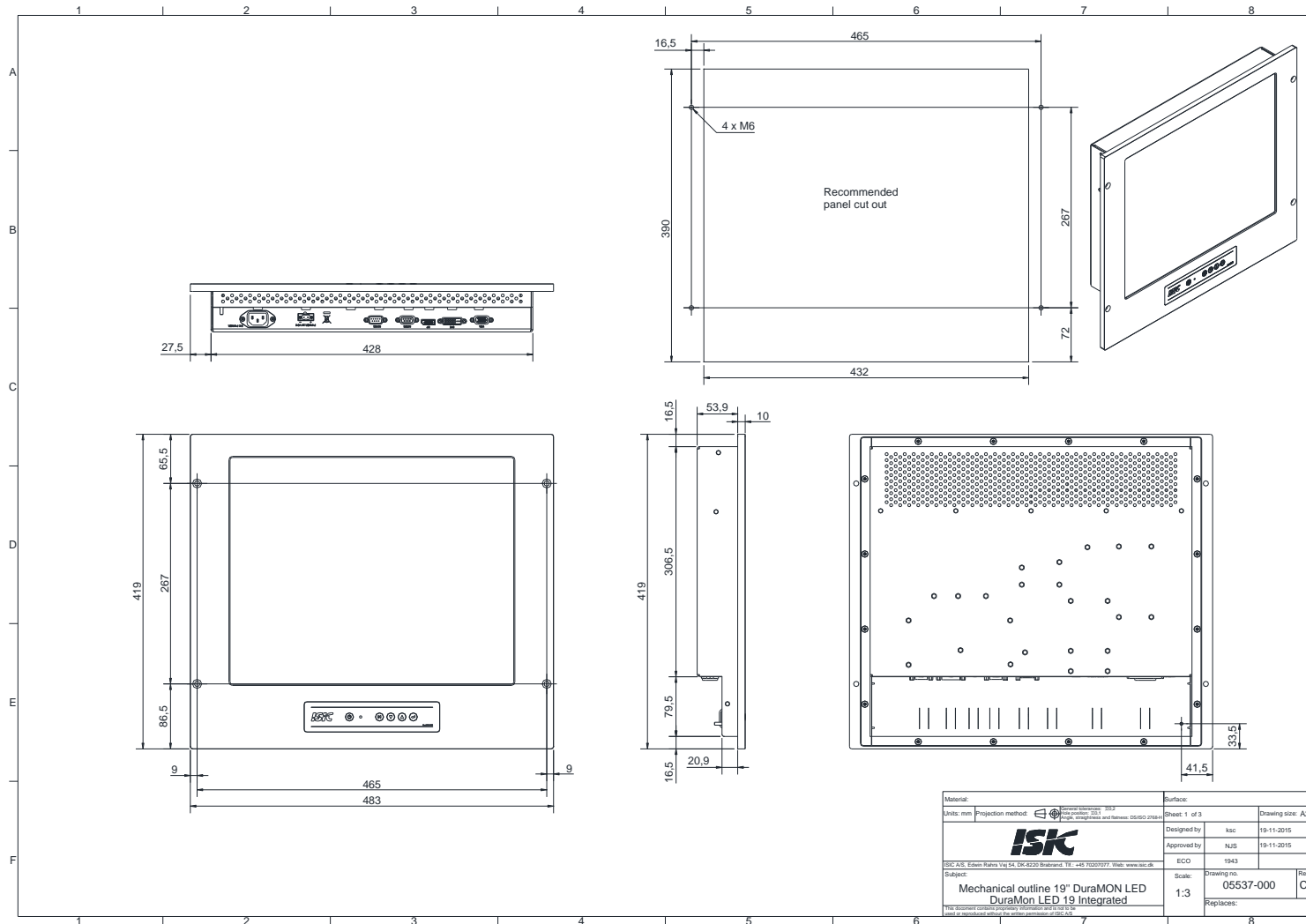

Material:	Surface:
Units: mm	Projection method:
ISIC	Sheet: 1 of 3
ISIC A/S, Edelevangsvej 54, DK-6220 Strømtved 1, Tlf: +45 70207077, Web: www.isic.dk	Designed by: KSC
Subject: Mechanical outline 19" DuraMON LED DuraMon LED 19 Integrated	Approved by: NJS
Scale: 1:3	ECD: 1943
Replaces:	Scale: 1:3
	Drawing no: 05537-000
	Rev: C
	Drawing size: A2



6.9 Mechanical outline DuraMON 22"

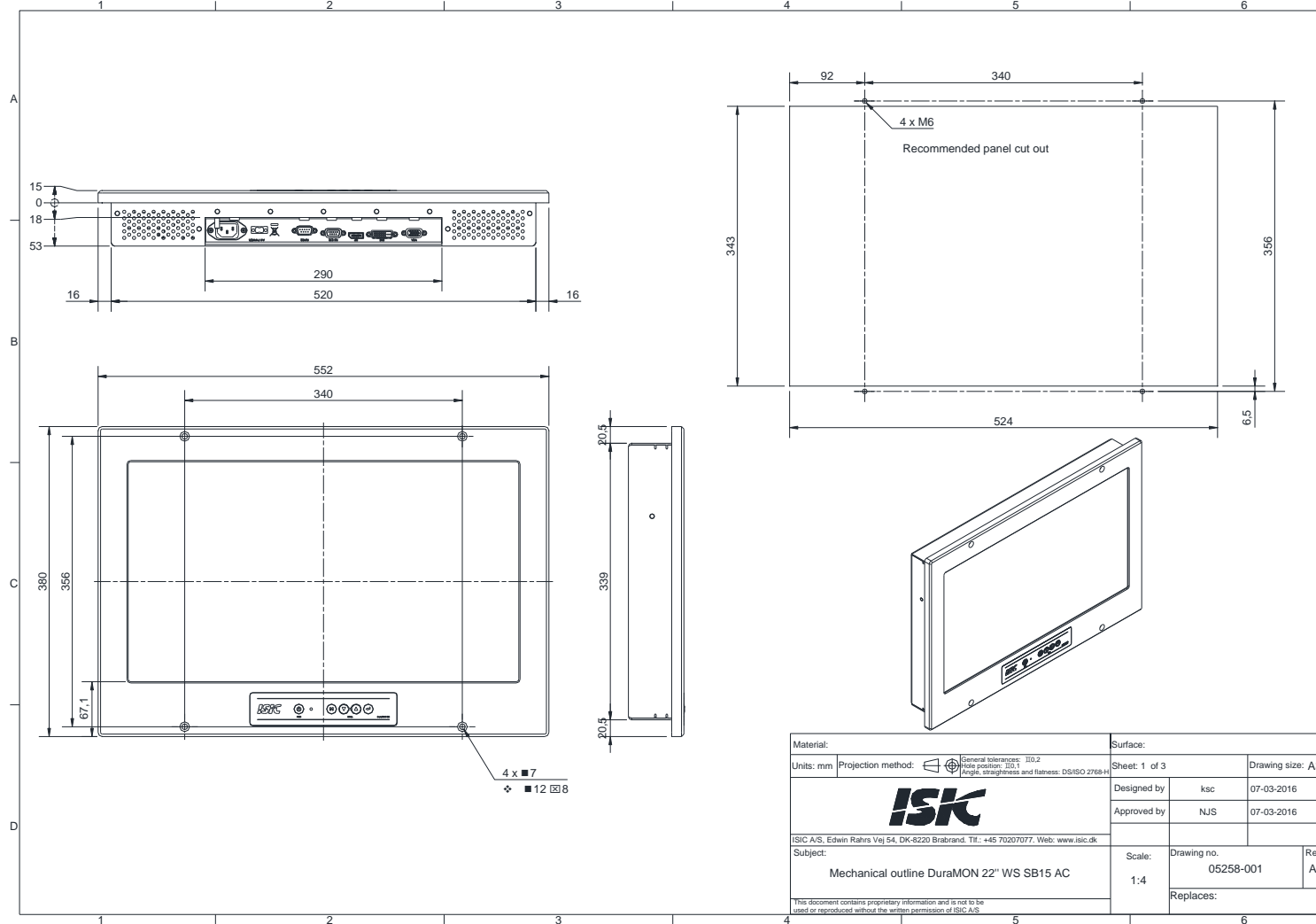

6.10 Mechanical outline DuraMON 24"

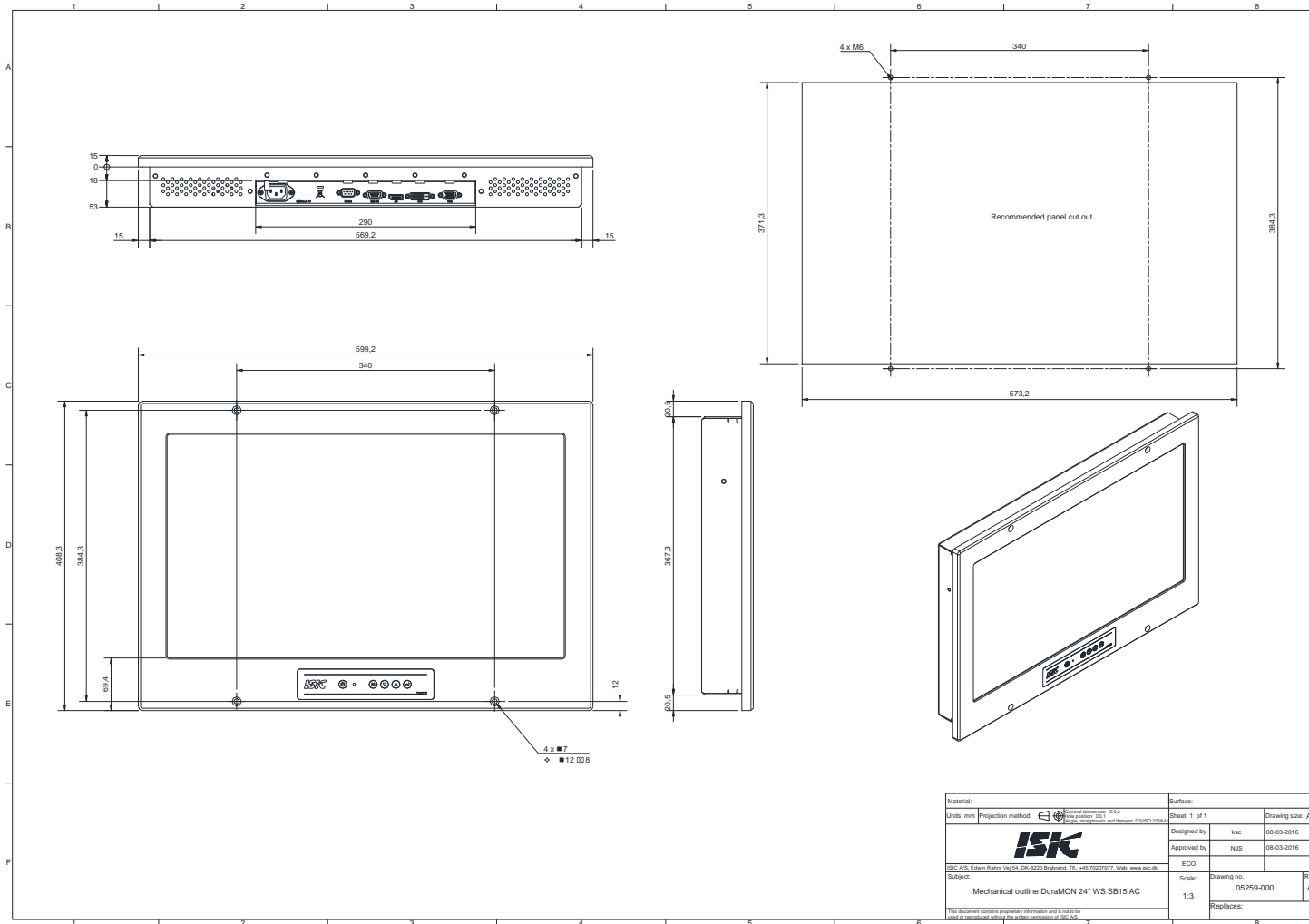

6.11 Mechanical outline DuraMON 26"

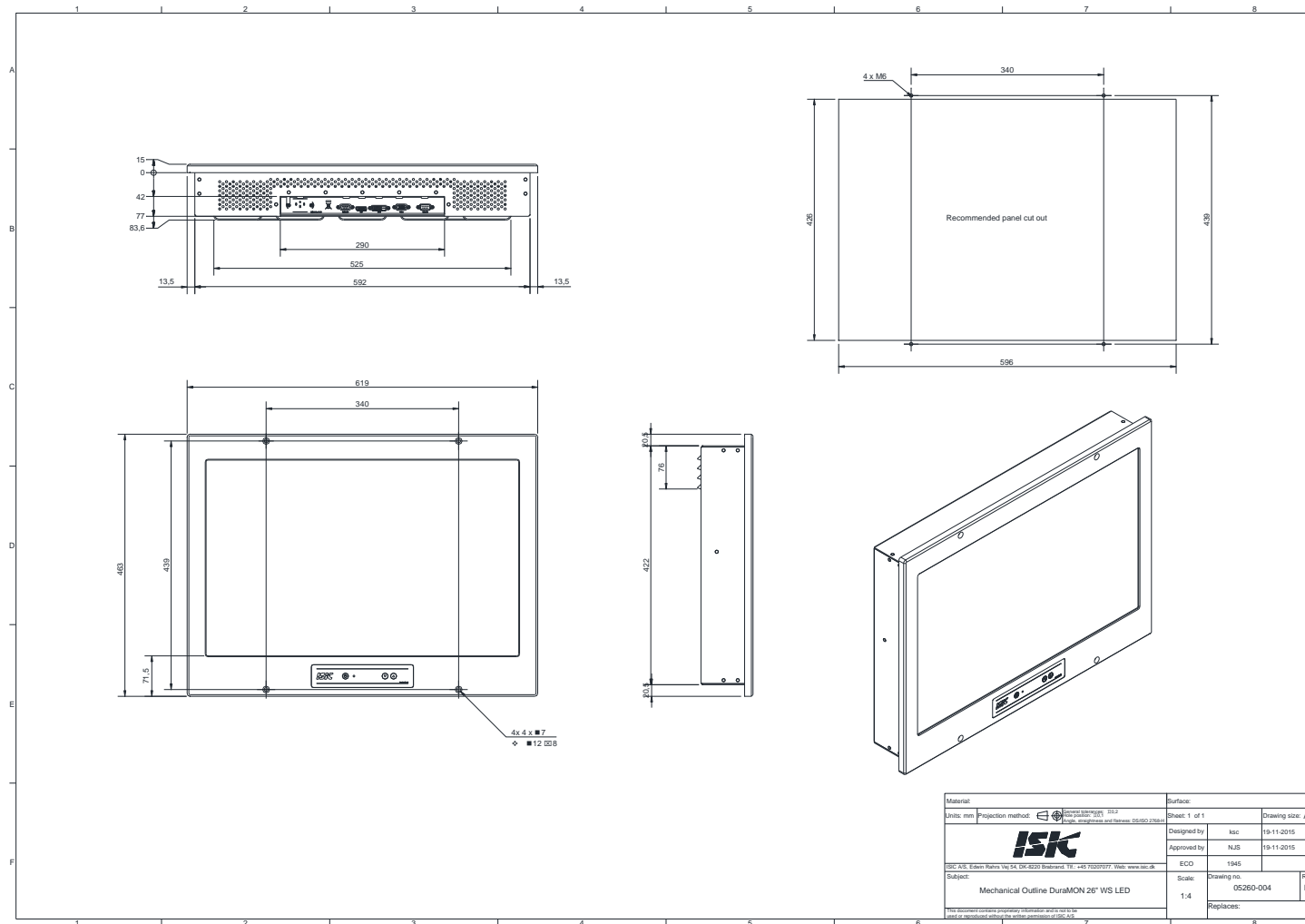

Material:	Surface:	Sheet: 1 of 1	Drawing size: A2
Units: mm	Projection method:	Designed by: ksc	19-11-2015
 <small>ISK A/S, Egevej 54 DK-8220 Sønderby, Tlf: +45 70207077, Web: www.isk.dk</small>		Approved by: NJS	19-11-2015
		ECO: 1945	
Subject: Mechanical Outline DuraMON 26" WS LED		Scale: 1:4	Drawing no. 05260-004
<small>This document contains proprietary information and is not to be used or reproduced without the written permission of ISK A/S.</small>		Replaces:	Rev: B



6.12 Mechanical outline DuraMON 27"

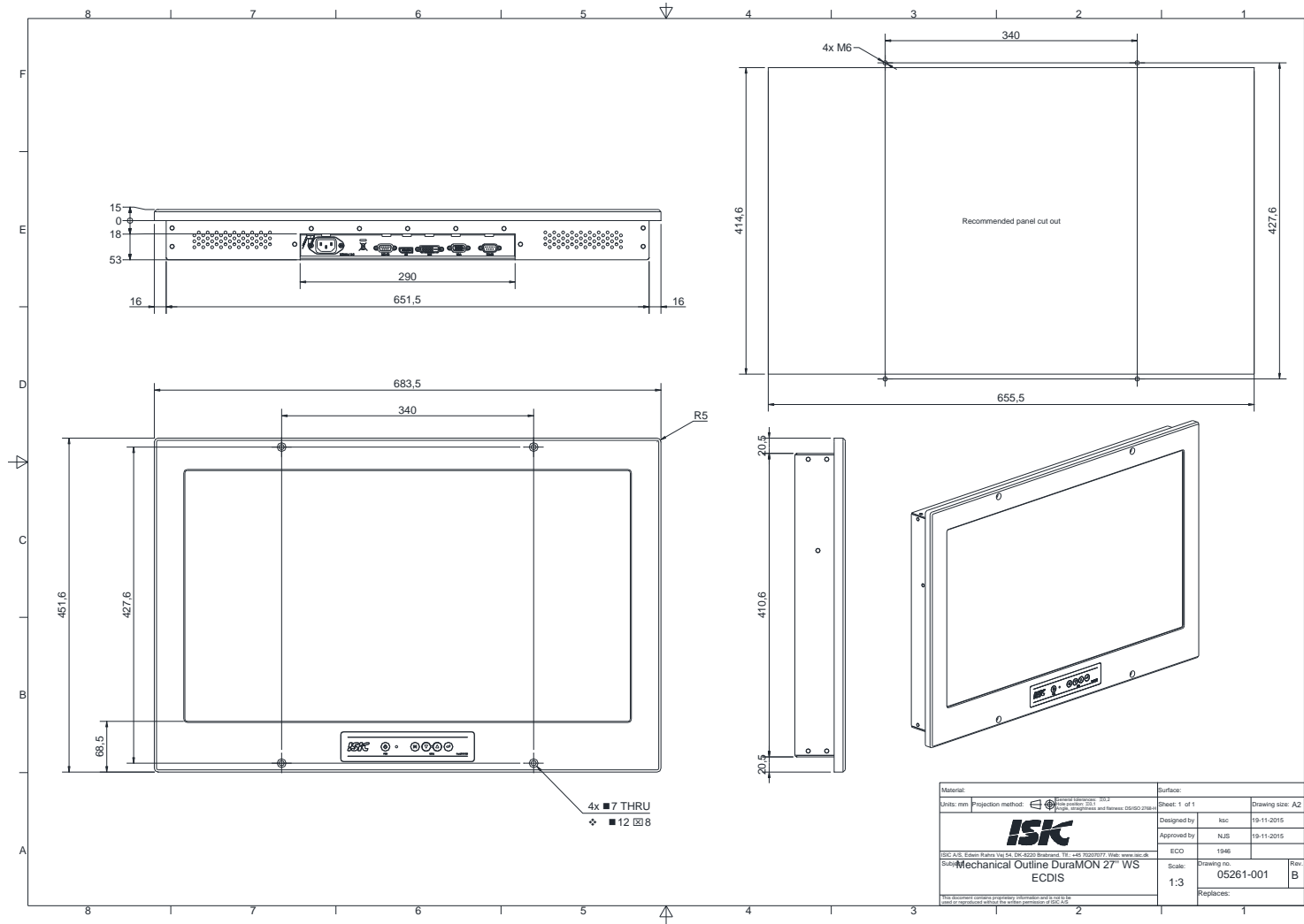

Material:	Surface:
Units: mm	Projection method:
ISK	
Mechanical Outline DuraMON 27" WS ECDIS	
Scale:	Drawing no.
1:3	05261-001
Replaces:	Rev.
	B



7 Touch screen option (19" only)

The OSD menu on the DuraMON does NOT contain any special entries with respect to the touch functions, as no features are controllable from the monitor itself.

All special functions has to be controlled from the PC

For description of special touch functions and help section, please go to the touch program folder, and select Readme or Help.

The touch screen on the monitor needs only to be connected to a PC via a RS-232 cable.

Touch Screen Software installation

The following instructions are based on the 3M MT7.11 driver.

The driver supports Windows XP and Windows 2000.

Unzip the MT7.... File, and run setup.exe

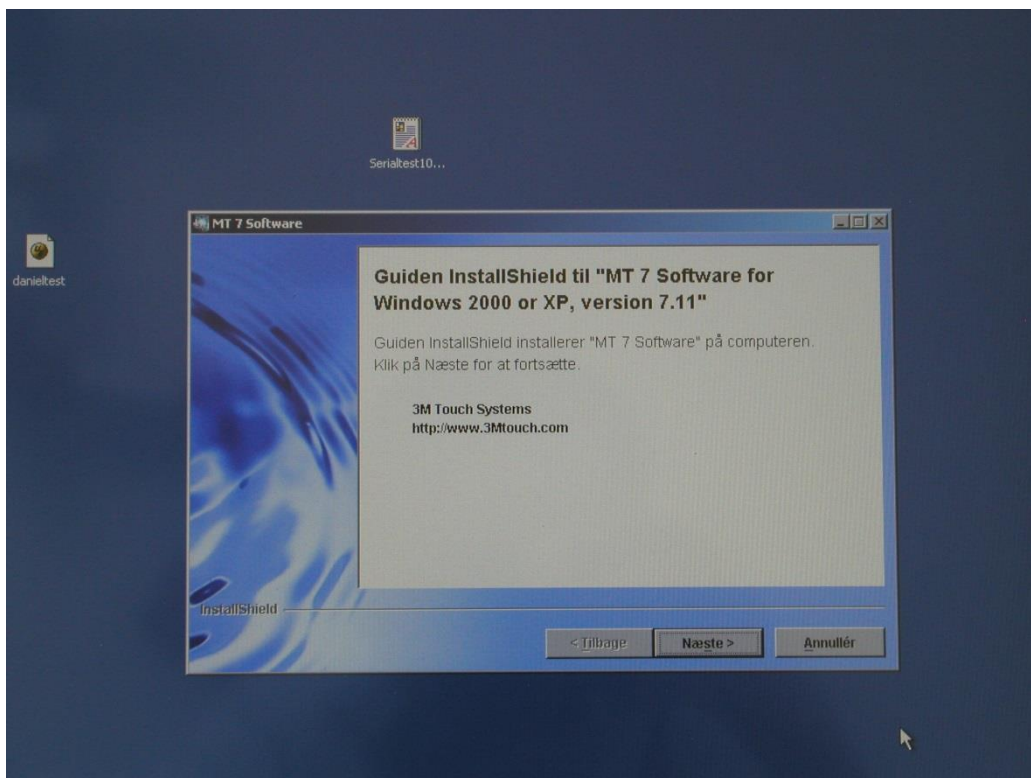

Follow the instructions on the screen.

After having completed the installation, the touch is working immediately. No reboot is necessary.



Calibration of Touch Screen

The Touch Screen is calibrated from the factory and normally no recalibration is needed.

If a Calibration is needed, go to the Programs/MT7 Software folder
Select the Control program

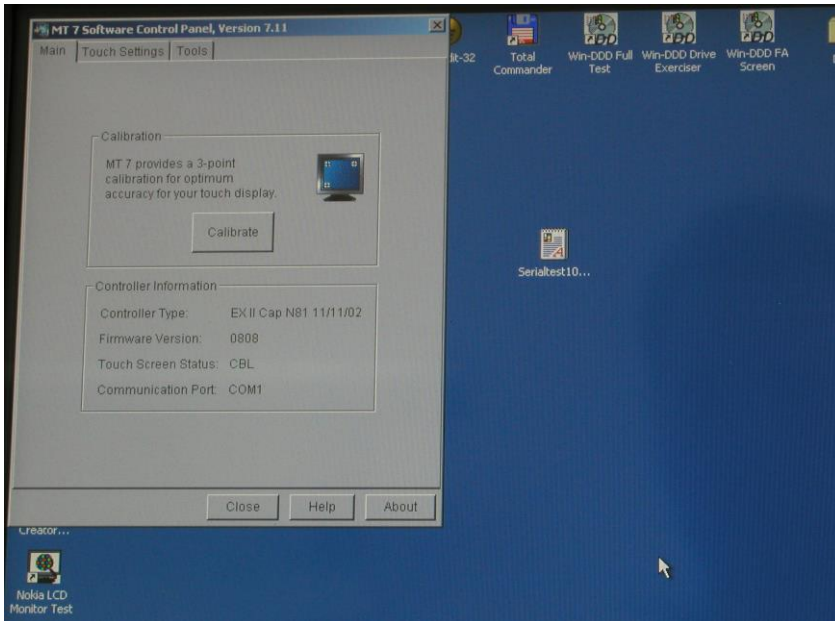

Press the Calibrate button, and place your finger at target points.

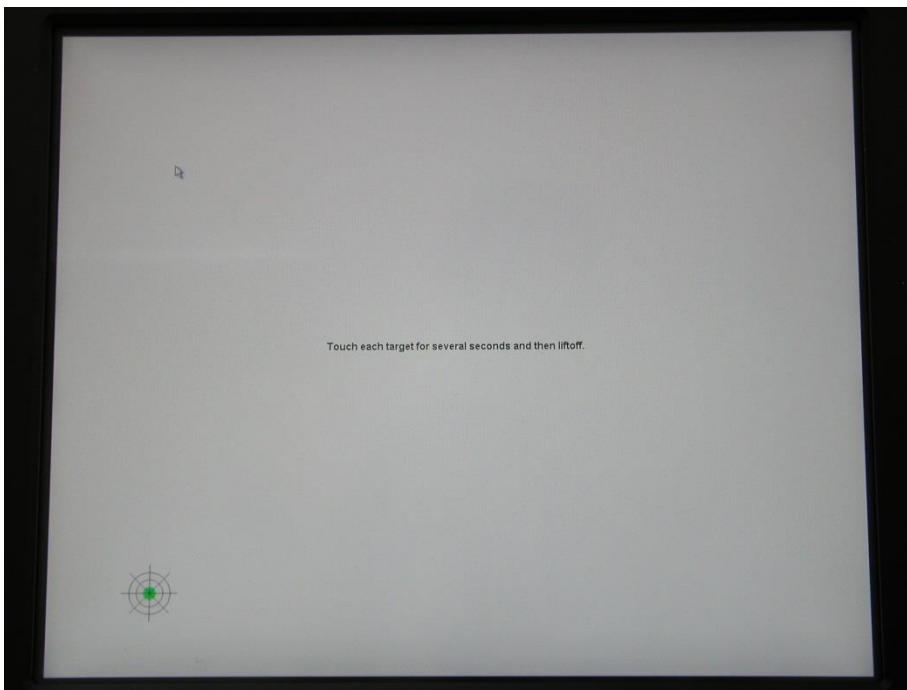

If the calibration process was not satisfactory, please re-calibrate.



8 ECDIS mode

Be aware that use of the backlight, brightness or contrast controls in ECDIS mode may inhibit visibility of information particularly at night!

To setup ECDIS on the system a color map must be downloaded from the monitor to the ECDIS application. Please see the Dura Serial Communication protocol for details.

9 Dura Serial Communication protocol

See document 04924-001 for protocol details.

The type of the product can be queried by sending the 'TYP' command, ref. the Serial Protocol Document.

Monitor	Typ response from monitor
DuraMON 15	DuraMON 15
DuraMON 19	DuraMON 19
DuraMON 22	DuraMON 22
DuraMON 24	DuraMON 24
DuraMON 26	DuraMON 26
DuraMON 27	DuraMON 27

10 Compass safe distance

Test object / condition	Minimum Compass safe distance [cm] (5.4°/H deviation or a horizontal magnetic flux of 0.094μT)	Minimum Compass safe distance [cm] (18°/H deviation or a horizontal magnetic flux of 0.313μT)
DuraMON 15	165	110
DuraMON 19	65	35
DuraMON 22 TN	205	135
DuraMON 22 WVA	175	110
DuraMON 24	215	140
DuraMON 26	225	135
DuraMON 27	180	110



11 Power Consumption

Test object / condition	P _{typ} [W]	P _{max} [W]
DuraMON 15	18	30
DuraMON 19	35	45
DuraMON 22 TN	25	30
DuraMON 22 WVA	31	35
DuraMON 24	25	30
DuraMON 26	50	60
DuraMON 27	30	35

12 Inrush current

Test object / condition	24 [VDC]	115 [VAC]	230 [VAC]
DuraMON 15	105	55	100
DuraMON 19	105	55	100
DuraMON 22	105	55	100
DuraMON 24	105	55	100
DuraMON 26	105	60	110
DuraMON 27	105	55	100



13 Popup Menu

Without entering the OSD menu it is possible to adjust brightness by pressing “up” or “down” key.

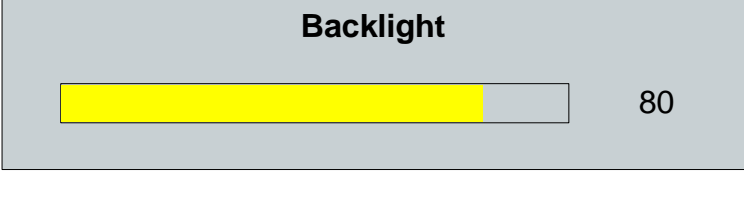
Press “up” or “down”	 <p style="text-align: center;">Backlight</p> <p style="text-align: right;">80</p>	It is now possible to adjust the backlight level by pressing either up- or down key.
----------------------	---	--

13.1 Advanced OSD

With the Advanced OSD (On Screen Display) you can modify the settings and control the special features of the DuraMON as described on the next pages.

To enter the Advanced OSD, press both the “ENTER” and the “MENU” button at the same time.

To navigate the Advanced OSD use the “UP” and “DOWN” buttons and press “ENTER” to select a specific setting. To get back to the previous menu point, press the “MENU” button.

13.2 Input select

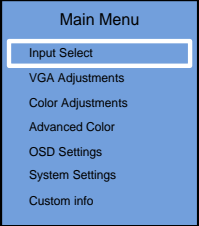
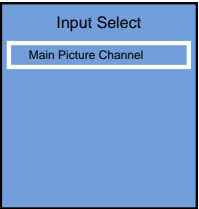
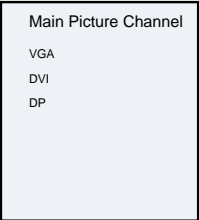
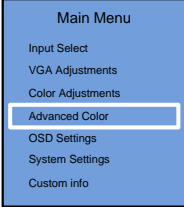
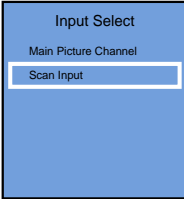
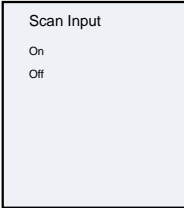
Input Select – Main Picture Channel	Input Select – Scan Input
<div style="display: flex; justify-content: space-between;"> <div style="width: 30%;">  <p style="text-align: center;">Main Menu</p> <ul style="list-style-type: none"> Input Select VGA Adjustments Color Adjustments Advanced Color OSD Settings System Settings Custom info </div> <div style="width: 65%;"> <p>The Main Picture Channel can be selected between all available inputs (VGA, Display Port and DVI).</p> </div> </div> <div style="display: flex; justify-content: space-between; margin-top: 10px;"> <div style="width: 30%;">  <p style="text-align: center;">Input Select</p> <ul style="list-style-type: none"> Main Picture Channel </div> <div style="width: 65%;"></div> </div> <div style="display: flex; justify-content: space-between; margin-top: 10px;"> <div style="width: 30%;">  <p style="text-align: center;">Main Picture Channel</p> <ul style="list-style-type: none"> VGA DVI DP </div> <div style="width: 65%;"></div> </div>	<div style="display: flex; justify-content: space-between;"> <div style="width: 30%;">  <p style="text-align: center;">Main Menu</p> <ul style="list-style-type: none"> Input Select VGA Adjustments Color Adjustments Advanced Color OSD Settings System Settings Custom info </div> <div style="width: 65%;"> <p>Scans Inputs for active source.</p> <p>Default is On.</p> </div> </div> <div style="display: flex; justify-content: space-between; margin-top: 10px;"> <div style="width: 30%;">  <p style="text-align: center;">Input Select</p> <ul style="list-style-type: none"> Main Picture Channel Scan Input </div> <div style="width: 65%;"></div> </div> <div style="display: flex; justify-content: space-between; margin-top: 10px;"> <div style="width: 30%;">  <p style="text-align: center;">Scan Input</p> <ul style="list-style-type: none"> On Off </div> <div style="width: 65%;"></div> </div>



13.3 VGA Adjustments

Image Adjustments – Auto Adjust	Image Adjustments – Clock
<div data-bbox="156 342 379 589"> <p>Main Menu</p> <ul style="list-style-type: none"> Input Select VGA Adjustments Color Adjustments Advanced Color OSD Settings System Settings Custom info </div> <div data-bbox="156 600 379 790"> <p>VGA Adjustments</p> <ul style="list-style-type: none"> Auto Adjust Clock Phase Hor. Position Ver. Position </div> <div data-bbox="156 801 379 958"> <p>Auto Adjust</p> <p>Auto Adjust</p> </div>	<p>Selecting auto adjust will force the system to adjust the image (clock, phase, bandwidth and position)</p> <div data-bbox="834 342 1058 589"> <p>Main Menu</p> <ul style="list-style-type: none"> Input Select VGA Adjustments Color Adjustments Advanced Color OSD Settings System Settings Custom info </div> <div data-bbox="834 600 1058 790"> <p>VGA Adjustments</p> <ul style="list-style-type: none"> Auto Adjust Clock Phase Hor. Position Ver. Position </div> <div data-bbox="834 801 1058 1037"> <p>Clock</p> <p>Value</p> <p>MIN [] MAX</p> </div>
<div data-bbox="156 1052 379 1328"> <p>Main Menu</p> <ul style="list-style-type: none"> Input Select VGA Adjustments Color Adjustments Advanced Color OSD Settings System Settings Custom info </div> <div data-bbox="156 1339 379 1529"> <p>VGA Adjustments</p> <ul style="list-style-type: none"> Auto Adjust Clock Phase Hor. Position Ver. Position </div> <div data-bbox="156 1541 379 1776"> <p>Phase</p> <p>Value</p> <p>MIN [] MAX</p> </div>	<div data-bbox="834 1052 1058 1328"> <p>Main Menu</p> <ul style="list-style-type: none"> Input Select VGA Adjustments Color Adjustments Advanced Color OSD Settings System Settings Custom info </div> <div data-bbox="834 1339 1058 1507"> <p>VGA Adjustments</p> <ul style="list-style-type: none"> Auto Adjust Clock Phase Hor. Position Ver. Position </div> <div data-bbox="834 1518 1058 1742"> <p>Hor. Position</p> <p>Value</p> <p>MIN [] MAX</p> </div>



Image Adjustments – Vert. Position

<p>Main Menu</p> <ul style="list-style-type: none"> Input Select VGA Adjustments Color Adjustments Advanced Color OSD Settings System Settings Custom info 	<p>The vertical position of the picture can be set here.</p>
<p>VGA Adjustments</p> <ul style="list-style-type: none"> Auto Adjust Clock Phase Hor. Position Ver. Position 	
<p>Ver. Position</p> <p>Value</p> <p>MIN [Slider] MAX</p>	

13.4 Color adjustments (not available in ECDIS mode)

Color Adjustment – Backlight

<p>Main Menu</p> <ul style="list-style-type: none"> Input Select VGA Adjustments Color Adjustments Advanced Color OSD Settings System Settings Custom info 	<p>It is possible to set the backlight level.</p> <p>Default is 50%.</p>
<p>Color Adjustments</p> <ul style="list-style-type: none"> Backlight Brightness Contrast Saturation Hue Auto Color Adjust 	<p><i>Unless popups or OSD is present it is possible to press the "UP" or "DOWN" button to adjust the backlight level and then press "ENTER" afterwards.</i></p>
<p>Backlight</p> <p>Value</p> <p>MIN [Slider] MAX</p>	

Color Adjustment – Brightness

<p>Main Menu</p> <ul style="list-style-type: none"> Input Select VGA Adjustments Color Adjustments Advanced Color OSD Settings System Settings Custom info 	<p>It is possible to set the brightness level.</p> <p>Default is 50%.</p>
<p>Color Adjustments</p> <ul style="list-style-type: none"> Backlight Brightness Contrast Saturation Hue Auto Color Adjust 	
<p>Brightness</p> <p>Value</p> <p>MIN [Slider] MAX</p>	



<p>Color Adjustment – Contrast</p>   	<p>It is possible to set the Contrast level.</p> <p>Default is 50%.</p>
<p>Color Adjustment – Saturation</p>   	<p>It is possible to set the color saturation level.</p> <p>Default is 50%.</p>
<p>Color Adjustment – Hue</p>   	<p>It is possible to set the Hue level.</p> <p>Default is 50%.</p>
<p>Color Adjustment – Auto Color Adjust</p>   	<p>It is possible to set use the command Auto Color Adjust.</p>



13.5 Advanced Color (not available in ECDIS mode)

Adv. Color Settings – Gamma	Adv. Color Settings – Color Temp
<div data-bbox="156 376 368 607"> <p>Main Menu</p> <ul style="list-style-type: none"> Input Select VGA Adjustments Color Adjustments Advanced Color OSD Settings System Settings Custom info </div> <div data-bbox="156 622 368 904"> <p>Advanced Color</p> <ul style="list-style-type: none"> Gamma Color Temperature Red Gain Green Gain Blue Gain </div> <div data-bbox="156 943 368 1167"> <p>Gamma</p> <ul style="list-style-type: none"> √ Native 2.2 2.4 </div>	<div data-bbox="834 376 1046 607"> <p>Main Menu</p> <ul style="list-style-type: none"> Input Select VGA Adjustments Color Adjustments Advanced Color OSD Settings System Settings Custom info </div> <div data-bbox="834 622 1046 801"> <p>Advanced Color</p> <ul style="list-style-type: none"> Gamma Color Temperature Red Gain Green Gain Blue Gain </div> <div data-bbox="834 817 1046 1041"> <p>Color Temperature</p> <ul style="list-style-type: none"> √ User 4200K 5000K 5400K 6500K 7500K 9300K </div>
<div data-bbox="156 1211 368 1442"> <p>Main Menu</p> <ul style="list-style-type: none"> Input Select VGA Adjustments Color Adjustments Advanced Color OSD Settings System Settings Custom info </div> <div data-bbox="156 1458 368 1637"> <p>Advanced Color</p> <ul style="list-style-type: none"> Gamma Color Temperature Red Gain Green Gain Blue Gain </div> <div data-bbox="156 1653 368 1883"> <p>Red Gain</p> <p>0 <input type="range" value="255"/> 255</p> </div>	<p>The rate for Red/Green/Blue can be set here from 0 – 255.</p> <p>Default is 255/255/255</p> <p>Note: These values are only adjustable when Color Temperature is set to 'User'</p>



13.6 OSD settings

OSD Settings – Menu Timeout	OSD Settings – Menu Hor. Pos.
<div data-bbox="156 344 357 568"> <p>Main Menu</p> <ul style="list-style-type: none"> Input Select VGA Adjustments Color Adjustments Advanced Color OSD Settings System Settings Custom info </div> <div data-bbox="156 584 357 730"> <p>OSD Settings</p> <ul style="list-style-type: none"> Timeout Hor. Position Ver. Position Transparency </div> <div data-bbox="156 745 357 958"> <p>Timeout</p> <p>Value</p> <p>MIN [Slider] MAX</p> </div> <p data-bbox="395 344 746 470">The Menu Timeout period can be set between 0 and 60 seconds in steps of 5 seconds.</p> <p data-bbox="395 506 667 535">Default is 30 seconds</p>	<div data-bbox="842 344 1043 568"> <p>Main Menu</p> <ul style="list-style-type: none"> Input Select VGA Adjustments Color Adjustments Advanced Color OSD Settings System Settings Custom info </div> <div data-bbox="842 584 1043 730"> <p>OSD Settings</p> <ul style="list-style-type: none"> Timeout Hor. Position Ver. Position Transparency </div> <div data-bbox="842 745 1043 958"> <p>Hor. Position</p> <p>Value</p> <p>MIN [Slider] MAX</p> </div> <p data-bbox="1082 344 1433 470">The Horizontal Position of the OSD can be set from 0 (left margin) to 100 (right margin).</p> <p data-bbox="1082 506 1353 535">Default is 0 (left margin).</p>
OSD Settings – Menu Vert. Pos.	OSD Settings – Transparency
<div data-bbox="156 1097 357 1321"> <p>Main Menu</p> <ul style="list-style-type: none"> Input Select VGA Adjustments Color Adjustments Advanced Color OSD Settings System Settings Custom info </div> <div data-bbox="156 1337 357 1482"> <p>OSD Settings</p> <ul style="list-style-type: none"> Timeout Hor. Position Ver. Position Transparency </div> <div data-bbox="156 1498 357 1711"> <p>Ver. Position</p> <p>Value</p> <p>MIN [Slider] MAX</p> </div> <p data-bbox="395 1097 746 1223">The Vertical Position of the OSD can be set from 0 (upper margin) to 100 (bottom margin).</p> <p data-bbox="395 1258 746 1323">Default is 50 (center of the display)</p>	<div data-bbox="842 1097 1043 1321"> <p>Main Menu</p> <ul style="list-style-type: none"> Input Select VGA Adjustments Color Adjustments Advanced Color OSD Settings System Settings Custom info </div> <div data-bbox="842 1337 1043 1482"> <p>OSD Settings</p> <ul style="list-style-type: none"> Timeout Hor. Position Ver. Position Transparency </div> <div data-bbox="842 1498 1043 1711"> <p>Transparency</p> <p>Value</p> <p>MIN [Slider] MAX</p> </div> <p data-bbox="1082 1097 1433 1223">The transparency of both the OSD and the Popup can be selected from 0 (solid) to 15 (clear)</p> <p data-bbox="1082 1258 1225 1288">Default is 2</p>

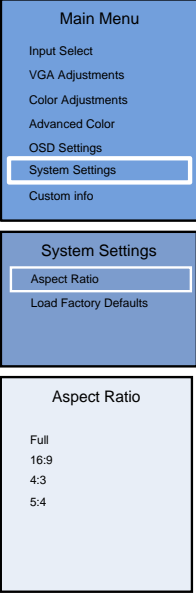
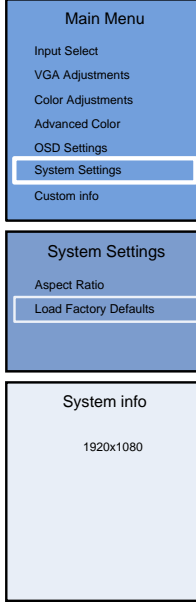

13.7 System settings

System Settings – Aspect Ratio	System Settings – Load Factory Defaults
 <p>The screenshot shows three menu screens. The first screen is the 'Main Menu' with 'System Settings' highlighted. The second screen is 'System Settings' with 'Aspect Ratio' highlighted. The third screen is 'Aspect Ratio' with options: Full, 16:9, 4:3, and 5:4.</p>	<p>Change Aspect Ratio. Default is Full.</p>  <p>The screenshot shows three menu screens. The first screen is the 'Main Menu' with 'System Settings' highlighted. The second screen is 'System Settings' with 'Load Factory Defaults' highlighted. The third screen is 'System info' showing '1920x1080'.</p> <p>Reset the monitor to factory settings.</p>



15 Troubleshooting

Problem	Cause	Solutions
No picture on display	Backlight level set to minimum	Increase backlight
No picture on display	Monitor turned off	Turn on the monitor
No picture on display	No input signal present	Apply signal
No picture on display	No power cord connected	Apply power
Buttons on front doesn't work	Unit in ECDIS mode	Press Menu + Enter to unlock the monitor
No picture on display	No power cord connected	Apply power
Buttons on front doesn't work	Keypad defect	Please do not try to open the unit. Send it to ISIC A/S for repair.
The unit will not turn on.	Unknown	Please do not try to open the unit. Send it to ISIC A/S for repair.

16 Servicing the unit

In case that the unit still fails after following the troubleshooting send the unit to ISIC for repair. There are no user serviceable parts inside and to ensure ECDIS compliance the monitor has to be recalibrated at ISIC.

17 Terms, Acronyms and abbreviations

Communication protocol:	Use a serial link to control various settings in the monitor
DVI-D:	Digital Visual Interface
ECDIS:	Electronic Chart Display and Information System
GtG:	Grey to Grey
IP20:	International Protection Rating (protected against objects with a size larger than 12.5mm)
IP65:	International Protection Rating (dust tight and protected against water jets)
OSD:	On Screen Display
VGA:	Video Graphics Array
DP:	Display Port
HDMI:	High-Definition Multimedia Interface



18 ISIC info / Support

In case you have inquiries or problems with your DuraMON, you have a number of possibilities to get support.

Company name: ISIC A/S

Head office: Edwin Rahrs Vej 54
DK – 8220 Brabrand
Denmark

Shipping address: Holmstrupgaardvej 5
DK-8220 Brabrand
Denmark

Telephone: +45 70 20 70 77
Fax: +45 70 20 79 76

Mail: isic@isic-systems.com
www: www.isic-systems.com

VAT number: DK 16 70 45 39

Bank Address: Handelsbanken A/S
Havneholmen 29
DK-1561 København V
Denmark

Bank Code: 0892
IBAN DKK: DK53 0892 0001 0159 69
IBAN EUR: DK48 0892 0003 0026 19
IBAN USD: DK26 0892 0003 0026 27
SWIFT: HANDDKKK

Contacts:
RFQ's: By fax to +45 70 20 79 76
By mail to sales@isic-systems.com

Orders: By fax to +45 70 20 79 76
By mail to orders@isic-systems.com

Support: Via homepage www.isic-systems.com under aftersales
By mail to service@isic-systems.com
During office-hours (Mo-Fr: CET 0800 - 1600) at +45 70 20 70 77

Service: Before shipment for service Request Return Material Authorisation number at homepage <http://www.isic-systems.com/aftersales/tech-support-rma/>
By mail to service@isic-systems.com



19 Revision history

Rev A	June 2016	First release
Rev B		Page 14 , corrected vert position and transparency in bottom menu. Page 18 , view distance for 27" changed to 1.08m
Rev C	2018	Page 2 , remove ISIC PN Move OSD menu to end of manual Page 4 , changed dimming from 0% to 1cd Page 9 , changed DC voltage to 18-31VDC, added resolution for 15" and 22", added RS232 touch interface for 19" Page 10,11 , changed weight of monitors, changed brightness of 27" to 300 cd, view distance for 24" changed to 1.00m, changed weight for 26" to 12Kg. Page 20 , changed compass distance for 15" to 110
Rev D	Marts, 2018	Page 9 , changed the ECDIS color



20 Appendix A: Pixel policy

ISO 9241-307:2008 guidelines for LCD pixel defects

Introduction

TFT displays consist of a set number of pixels. Each pixel consists of 3 sub-pixels also called dots (one red, one blue and one green). Every sub-pixel is addressed by its own transistor. As a result, the manufacturing of glass substrate is very complex.

Due to the nature of this manufacturing process, occasional defects can occur. Pixel defects or failures cannot be fixed or repaired and may occur at any stage during the service life of the TFT display.

To regulate the acceptability of defects and protect the end user, ISIC A/S complies with the ISO 9241-307:2008 standard. This standard recommends how many defects are considered acceptable in a display, before it should be replaced within the terms of the warranty.

Monitor classification

ISO 9241-307:2008

Allowed defects per type per million pixels						
Defect classes	Pixel defects			Cluster defect		
	Type 1	Type 2	Type 3 total ($2 \times N_{3a} + N_{3b}$)	Type 1	Type 2	Type 3
Class: 0	0	0	0	0	0	0
Class: I	1	1	5	0	0	0
Class: II	2	2	10	0	0	1
Class: III	5	15	100	0	0	5

ISIC TFT monitors comply with ISO 9241-307:2008 Class II.

Special agreements about other classifications can be made between ISIC A/S and the customer.

Measurement method/monitoring conditions for pixel defects

In compliance with the ISO-9241-307:2008 standard, the following conditions are observed:

- Final check for pixel fault undertaken right after burn-in, i.e. with pre-heating of the display.
- Surrounding temperature $25^{\circ}\text{C} \pm 5^{\circ}\text{C}$
- Relative air humidity 40–70%

Pixel definition

Every pixel consists of three sub-pixels/dots (red, blue, green).

Every sub-pixel has its own transistor.

The three sub-pixels/dots must be considered as one unit.



Pixel

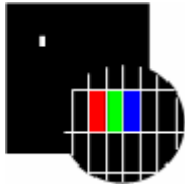

Pixel defect type 1 Pixel constantly lit

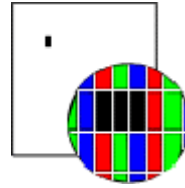

Pixel defect type 2 Pixel constantly dark

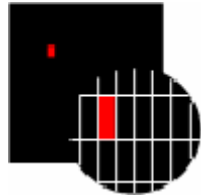

Pixel defect type 3a
Sub-pixel/dot (red, blue, green) constantly lit

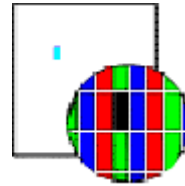

Pixel defect type 3b
Sub-pixel/dot (red, blue, green) constantly dark

Cluster

A cluster consists of 5 x 5 pixels.

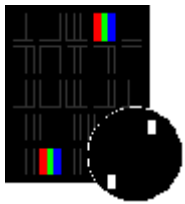

Cluster pixel defect type 1

Pixels in a cluster area constantly lit



Cluster pixel defect type 2

Pixels in a cluster area constantly dark

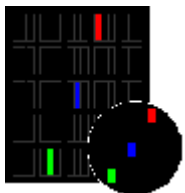

Cluster pixel defect type 3a
Sub-pixels/dots in a cluster area constantly lit



Cluster pixel defect type 3b
Sub-pixels/dots in a cluster area constantly dark



Pixel faults accepted by ISIC A/S

The maximum number of pixel faults that is considered acceptable at different screen resolutions is shown in the table below.

This is the native resolution and not the resolution as adjusted by user.

Class II

Allowable number of pixel faults in monitor applications							
Screen type	Native resolution	Number of pixels	Pixel defect type 1	Pixel defect type 2	Pixel defect Type 3 total ($2 \times N_{3a} + N_{3b}$)	Cluster defect type 1 and 2	Cluster defect type 3
WVGA	800x480	384,000	0	0	3	0	0
XGA	1024x768	768,432	1	1	7	0	0
WXGA	1280x800	1,024,000	2	2	10	0	1
SXGA	1280x1024	1,310,720	2	2	13	0	1
UXGA	1600x1200	1,920,000	3	3	19	0	1
FHD	1920x1080	2,073,600	4	4	20	0	2
WUXGA	1920x1200	2,304,000	4	4	23	0	2





Edwin Rahrs Vej 54

DK-8220 Brabrand

Denmark

Web: <http://www.isic-systems.com>

Email: service@isic.dk

