

User Guide

UniStream® Built-in

US5-B5-B1, US5-B10-B1, US5-B5-TR22,
US5-B10-TR22, US5-B5-T24, US5-B10-T24,
US5-C5-B1, US5-C10-B1, US5-C5-TR22,
US5-C10-TR22, US5-C5-T24, US5-C10-T24

US7-B5-B1, US7-B10-B1, US7-B5-TR22,
US7-B10-TR22, US7-B5-T24, US7-B10-T24,
US7-C5-B1, US7-C10-B1, US7-C5-TR22,
US7-C10-TR22, US7-C5-T24, US7-C10-T24

US10-B5-B1, US10-B10-B1, US10-B5-TR22,
US10-B10-TR22, US10-B5-T24, US10-B10-T24,
US10-C5-B1, US10-C10-B1, US10-C5-TR22,
US10-C10-TR22, US10-C5-T24, US10-C10-T24

US15-B10-B1, US15-C10-B1

This guide provides basic installation information for specific UniStream® models with built-in I/O. Technical specifications may be downloaded from the Unitronics website.

General Features

Unitronics' UniStream® Built-in series are PLC+HMI All-in-One programmable controllers that comprise a built-in CPU, an HMI panel, and built-in I/Os.

The series is available in two versions: UniStream Built-in and UniStream Built-in Pro.

Note that a model number that includes:

- **B5/C5** refers to UniStream Built-in
- **B10/C10** refers to UniStream Built-in Pro. These models offer additional features, detailed below.

HMI	<ul style="list-style-type: none">▪ Resistive Color Touch-screens▪ Rich graphic library for HMI design
Power Features	<ul style="list-style-type: none">▪ Built-in Trends and Gauges, auto-tuned PID, data tables, data sampling, and Recipes▪ UniApps™: Access & edit data, monitor, troubleshoot & debug and more – via HMI or remotely via VNC▪ Security: Multi-level password protection▪ Alarms: Built-in system, ANSI/ISA standards
I/O Options	<ul style="list-style-type: none">▪ Built-in I/O configuration, varies according to model▪ Local I/O via UAG-CX series I/O expansion adapters and standard UniStream Uni-I/O™ modules▪ Remote I/O using UniStream Remote I/O or via EX-RC1▪ US15 only – Integrate I/O into your system by using UAG-BACK-IOADP, snap onto the panel for an all-in-one configuration.
COM Options	<ul style="list-style-type: none">▪ Built-in ports: 1 Ethernet, 1 USB host, 1 Mini-B USB device port (USB-C in US15)▪ Serial and CANbus ports may be added via UAC-CX modules
COM Protocols	<ul style="list-style-type: none">▪ Fieldbus: CANopen, CAN Layer2, MODBUS, EtherNetIP and more. Implement any serial RS232/485, TCP/IP, or CANbus third-party protocols via Message Composer▪ Advanced: SNMP Agent/Trap, e-mail, SMS, modems, GPRS/GSM, VNC Client, FTP Server/Client
Programming Software	All-in-One software for hardware configuration, communications, and HMI /PLC applications, available as a free download from Unitronics.

Comparison table	Feature	B5/C5	B10/C10 (Pro)
	System Memory	3GB	6GB
	Audio Jack	No	Yes
	Video/RSTP Support	No	Yes
	Web Server	No	Yes
	SQL Client	No	Yes



Before You Begin

Before installing the device, the user must:

- Read and understand this document.
- Verify the Kit Contents.

Alert Symbols and General Restrictions

When any of the following symbols appear, read the associated information carefully.

Symbol	Meaning	Description
	Danger	The identified danger causes physical and property damage.
	Warning	The identified danger could cause physical and property damage.
Caution	Caution	Use caution.

- All examples and diagrams are intended to aid understanding, and do not guarantee operation. Unitronics accepts no responsibility for actual use of this product based on these examples.
- Please dispose of this product according to local and national standards and regulations.
- This product should be installed only by qualified personnel.
- If the equipment is used in a manner not specified by the manufacturer, the protection provided by the equipment may be impaired.

-  Failure to comply with appropriate safety guidelines can cause severe injury or property damage.
- Do not attempt to use this device with parameters that exceed permissible levels.
- Do not connect/disconnect the device when power is on.

Environmental Considerations

-  Ventilation: 10mm space is required between the device top/bottom edges and the enclosure's walls
- Do not install in areas with: excessive or conductive dust, corrosive or flammable gas, moisture or rain, excessive heat, regular impact shocks or excessive vibration, in accordance with the standards and limitations given in the product's technical specification sheet.
- Do not place in water or let water leak onto the unit.
- Do not allow debris to fall inside the unit during installation.
- Install at maximum distance from high-voltage cables and power equipment.

UL Compliance

The following section is relevant to Unitronics' products that are listed with the UL.

The following models are UL listed for Hazardous Locations: US5-B5-B1, US5-B10-B1, US7-B5-B1 and US7-B10-B1

The following models are UL listed for Ordinary Location:

- USL followed by -, followed by 050 or 070 or 101, followed by B05
- US followed by 5 or 7 or 10, followed by -, followed by B5 or B10 or C5 or C10, followed by -, followed by B1 or TR22 or T24 or RA28 or TA30 or R38 or T42



Models from series US5, US7 and US10 that include "T10" or "T5" in the model name are suitable for mounting on the flat surface of Type 4X enclosure. For examples: US7-T10-B1, US7-T5-R38, US5-T10-RA22 and US5-T5-T42.

UL Ordinary Location

In order to meet the UL ordinary location standard, panel-mount this device on the flat surface of Type 1 or 4X enclosures

UL Ratings, Programmable Controllers for Use in Hazardous Locations, Class I, Division 2, Groups A, B, C and D

These Release Notes relate to all Unitronics products that bear the UL symbols used to mark products that have been approved for use in hazardous locations, Class I, Division 2, Groups A, B, C and D.

Caution	This equipment is suitable for use in Class I, Division 2, Groups A, B, C and D, or Non-hazardous locations only.
	▪ Input and output wiring must be in accordance with Class I, Division 2 wiring methods and in accordance with the authority having jurisdiction.
	▪ WARNING—Explosion Hazard—substitution of components may impair suitability for Class I, Division 2.
	▪ WARNING – EXPLOSION HAZARD – Do not connect or disconnect equipment unless power has been switched off or the area is known to be non-hazardous.
	▪ WARNING – Exposure to some chemicals may degrade the sealing properties of material used in Relays.

- This equipment must be installed using wiring methods as required for Class I, Division 2 as per the NEC and/or CEC.

Panel-Mounting

For programmable controllers that can be mounted also on panel, in order to meet the UL Haz Loc standard, panel-mount this device on the flat surface of Type 1 or Type 4X enclosures.

Communication and Removable Memory Storage

When products comprise either USB communication port, SD card slot, or both, neither the SD card slot nor the USB port are intended to be permanently connected, while the USB port is intended for programming only.

Removing / Replacing the battery

When a product has been installed with a battery, do not remove or replace the battery unless the power has been switched off, or the area is known to be non-hazardous.

Please note that it is recommended to back up all data retained in RAM, in order to avoid losing data when changing the battery while the power is switched off. Date and time information will also need to be reset after the procedure.

UL des zones ordinaires:

Pour respecter la norme UL des zones ordinaires, monter l'appareil sur une surface plane de type de protection 1 ou 4X

Certification UL des automates programmables, pour une utilisation en environnement à risques, Class I, Division 2, Groups A, B, C et D.

Cette note fait référence à tous les produits Unitronics portant le symbole UL - produits qui ont été certifiés pour une utilisation dans des endroits dangereux, Classe I, Division 2, Groupes A, B, C et D.

Attention

- Cet équipement est adapté pour une utilisation en Classe I, Division 2, Groupes A, B, C et D, ou dans Non-dangereux endroits seulement.
- Le câblage des entrées/sorties doit être en accord avec les méthodes de câblage selon la Classe I, Division 2 et en accord avec l'autorité compétente.
- AVERTISSEMENT: Risque d'Explosion – Le remplacement de certains composants rend caduque la certification du produit selon la Classe I, Division 2.
- AVERTISSEMENT - DANGER D'EXPLOSION - Ne connecter pas ou ne débranche pas l'équipement sans avoir préalablement coupé l'alimentation électrique ou la zone est reconnue pour être non dangereuse.
- AVERTISSEMENT - L'exposition à certains produits chimiques peut dégrader les propriétés des matériaux utilisés pour l'étanchéité dans les relais.
- Cet équipement doit être installé utilisant des méthodes de câblage suivant la norme Class I, Division 2 NEC et /ou CEC.



Montage de l'écran:

Pour les automates programmables qui peuvent aussi être monté sur l'écran, pour pouvoir être au standard UL, l'écran doit être monté dans un coffret avec une surface plane de type 1 ou de type 4X.

Communication et de stockage amovible de mémoire (carte mémoire)

Produits comprend un port USB de communication, soit un port carte SD ou les deux, ni le port SD, ni le port USB ne sont censés être utilisés en permanence, tandis que l'USB est destiné à la programmation uniquement.

Retrait / Remplacement de la batterie

Lorsqu'un produit a été installé avec une batterie, retirez et remplacez la batterie seulement si l'alimentation est éteinte ou si l'environnement n'est pas dangereux.

Veillez noter qu'il est recommandé de sauvegarder toutes les données conservées dans la RAM, afin d'éviter de perdre des données lors du changement de la batterie lorsque l'alimentation est coupée. Les informations sur la date et l'heure devront également être réinitialisées après la procédure.

Kit Contents

- 1 PLC+HMI controller
- 4,8,10 mounting brackets (US5/US7, US10, US15)
- 1 panel mounting seal
- 2 panel supports (US7/US10/US15 only)
- 1 power terminal block
- 2 I/O terminal blocks (provided only with models comprising built-in I/Os)
- 1 Battery

Product Diagram

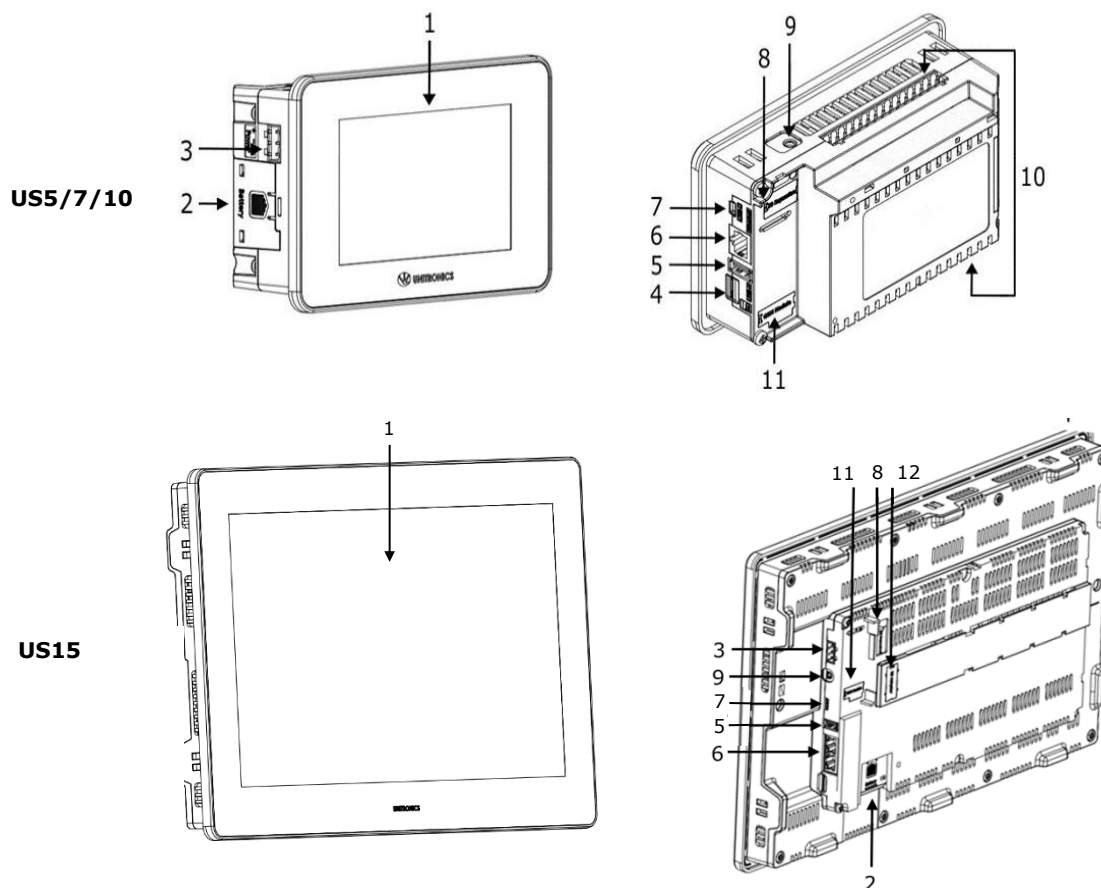

Front and Rear View

1	Screen Protection	A plastic sheet attached to the screen for protection. Remove it during installation of the HMI Panel.
2	Battery Cover	The battery is supplied with the unit, but must be installed by the user.
3	Power Supply Input	Connection point for the controller power source. Connect the Terminal Block supplied with the kit to the end of the power cable.
4	microSD Slot	Supports standard microSD cards.
5	USB Host port	Provides the interface for external USB devices.
6	Ethernet port	Supports high-speed Ethernet communications.
7	USB Device	Use for application download and direct PC-UniStream communication.
8	I/O Expansion Jack	Connection point for an I/O Expansion Port. Ports are supplied as part of I/O Expansion Model Kits. Kits are available by separate order. Note that UniStream® Built-in is compatible only with adapters from the series UAG-CX.
9	Audio Jack	Pro models only. This 3.5mm Audio jack enables you to connect external audio equipment.
10	Built-in I/O	Model-dependent. Present in models with built-in I/O configurations.
11	Uni-COM™ CX Module Jack	Connection point for up to 3 stack-on modules. These are available by separate order.
12	UAG-BACK-IOADP Adapter Jack	Connection point for snap onto the panel for an all-in-one configuration. Adapter is available by Separate order.

Installation Space Considerations

Allocate space for:

- the controller
- any modules that will be installed
- access to ports, jacks, and the microSD card slot

For exact dimensions, please refer to the Mechanical Dimensions shown below.

Mechanical Dimensions

UniStream 5"

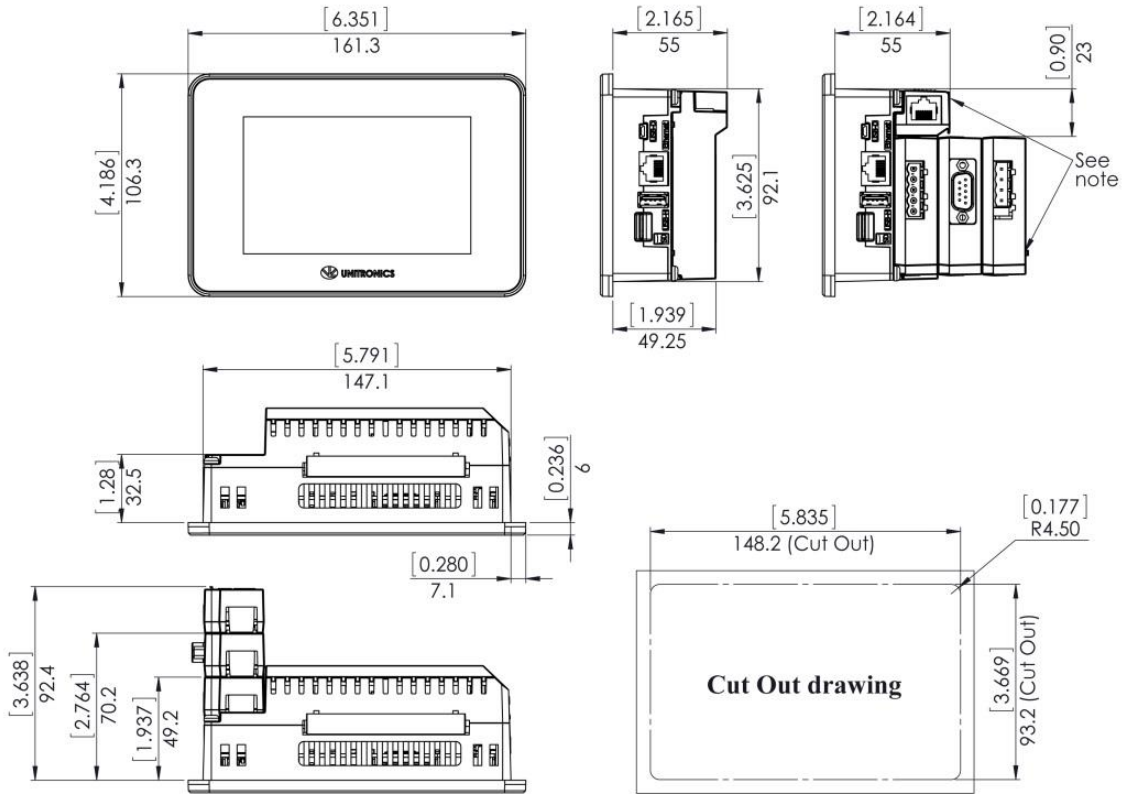

UniStream 7"

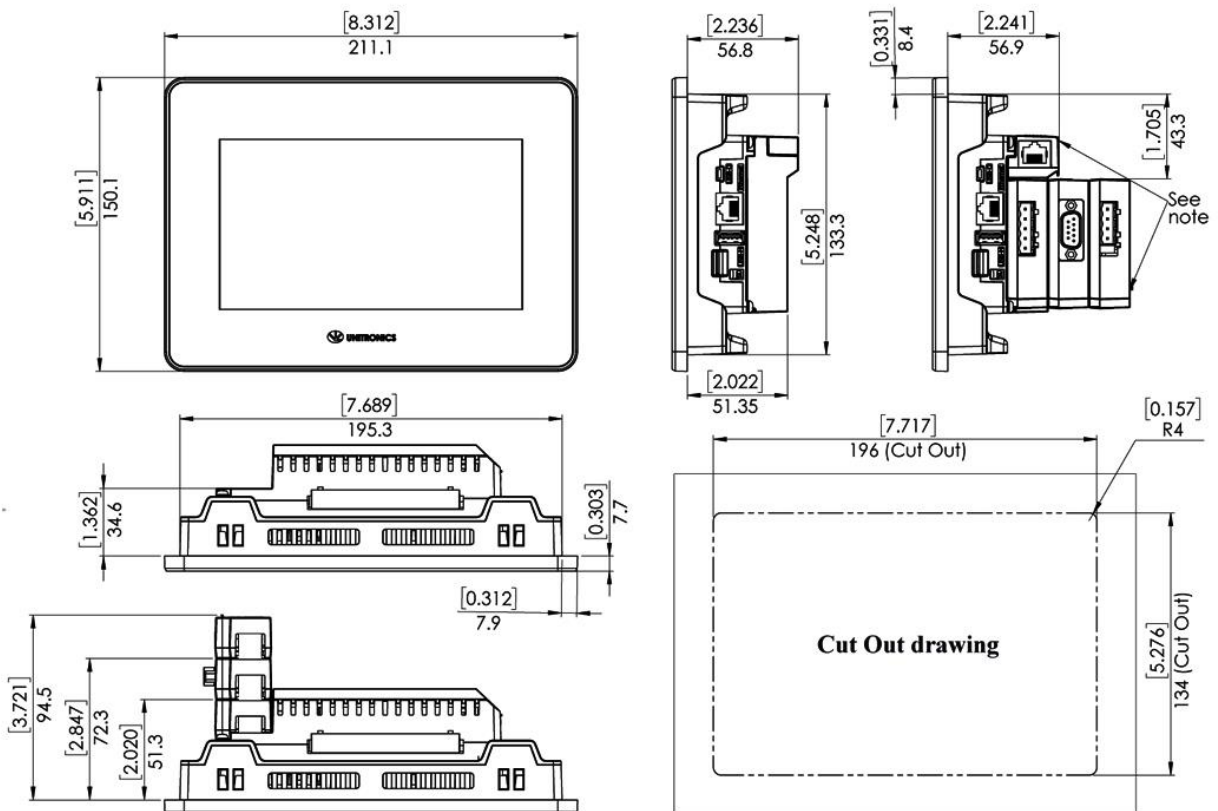

UniStream 10.1"

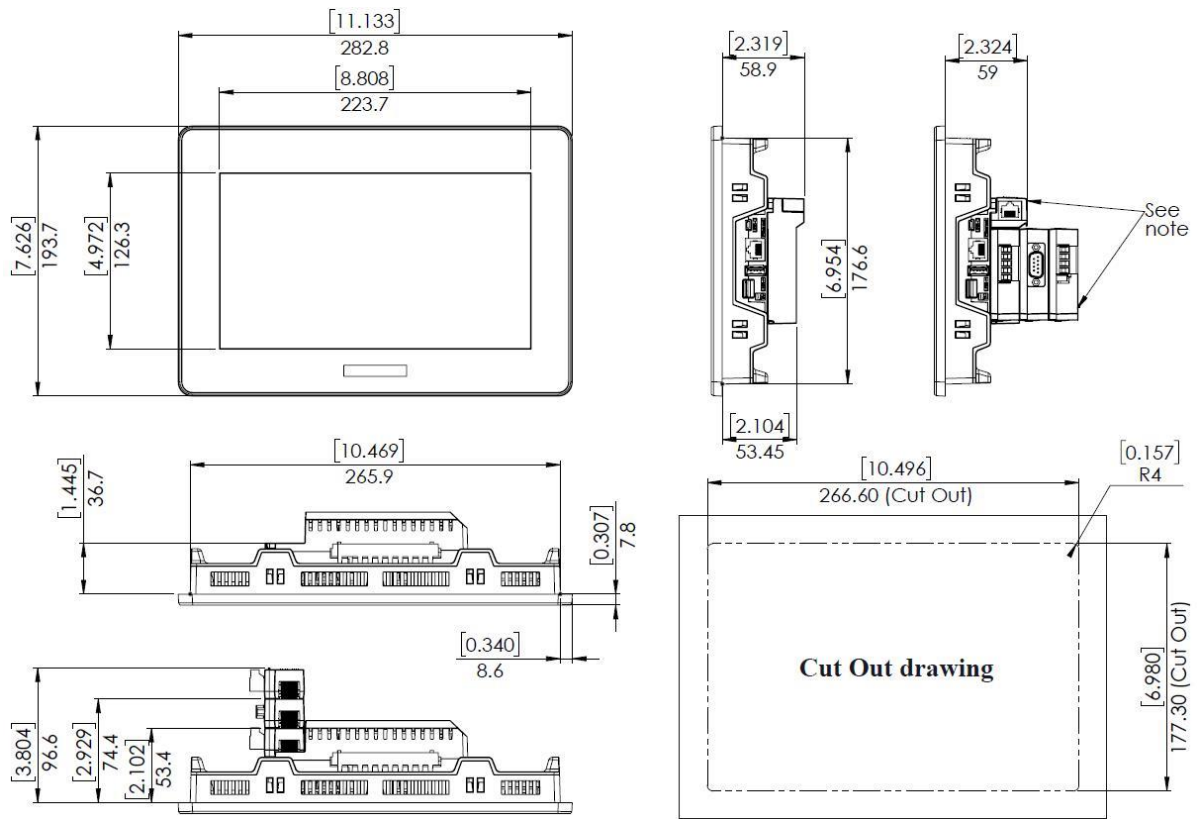

UniStream 15.6"

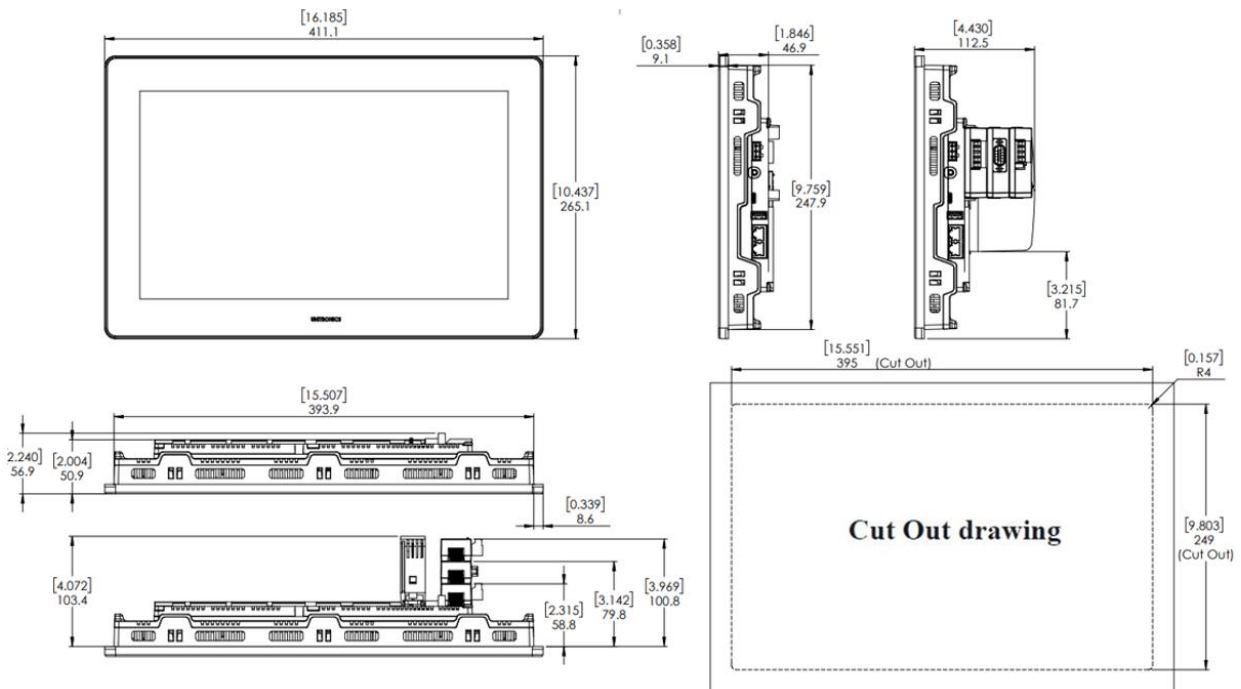

NOTE Allow space for modules to be snapped onto the back of the controller, if required by your application. Modules are available by separate order.

Panel Mounting

- NOTE**
- Mounting panel thickness must be less or equal to 5mm (0.2").
 - Ensure that the space considerations are met.

1. Prepare a panel cut-out according to the dimensions as shown in the previous section.
2. Slide the controller into the cut-out, ensuring that the Panel Mounting Seal is in place as shown below.
3. Push the mounting brackets into their slots on the sides of the panel as shown below.
4. Tighten the bracket screws against the panel. Hold the brackets securely against the unit while tightening the screws. The torque required is 0.35 N·m (3.1 in-lb).

When properly mounted, the panel is squarely situated in the panel cut-out as shown below.

- Caution**
- Do not apply torque exceeding 0.35 N·m (3.1 in-lb) of torque to tighten the bracket screws. Using excessive force to tighten the screw can damage this product.

UniStream 5"

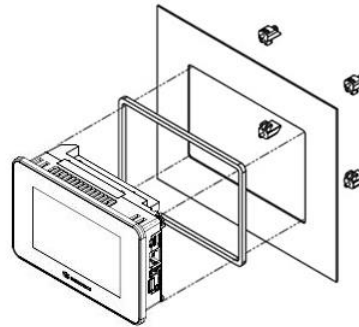
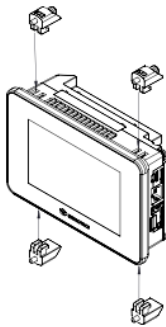

UniStream 7"

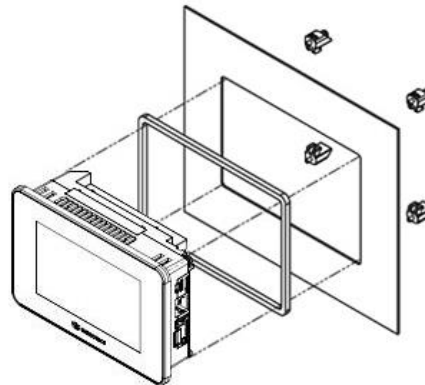
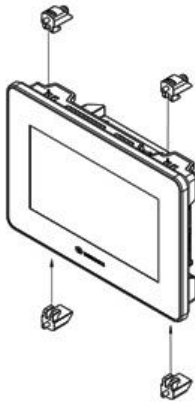

UniStream 10.1"

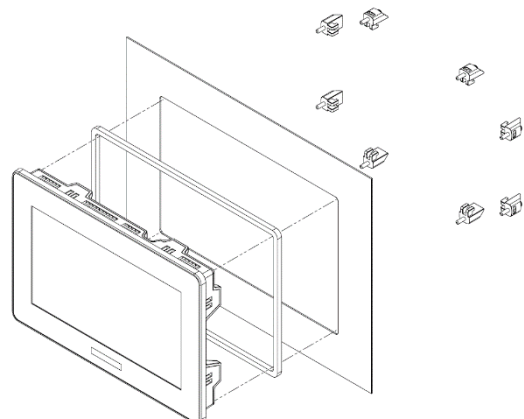
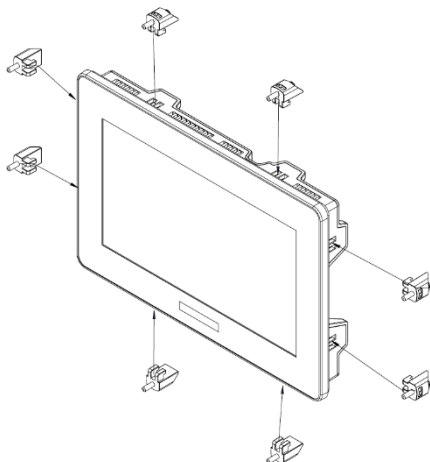

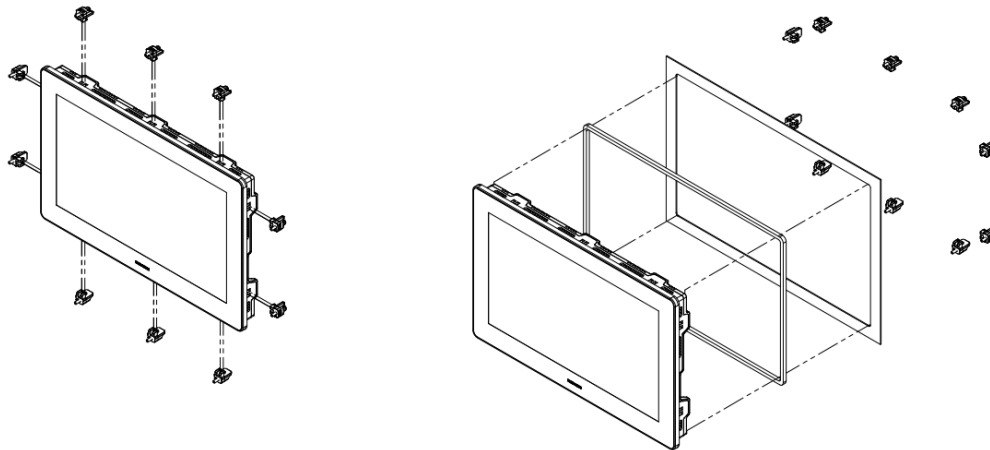
UniStream 15.6"**Battery: Back-up, First Use, Installation, and Replacement****Back-up**

In order to preserve back-up values for RTC and system data in the event of power off, the battery must be connected.

First Use

The battery is protected by a removable cover on the side of the controller.

The battery is supplied installed inside the unit, with a plastic tab preventing contact which must be removed by the user.

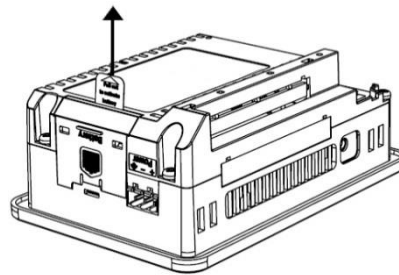
**Battery Installation and Replacement**

- ⚠ Use proper precautions to prevent Electro-Static Discharge (ESD) while servicing the battery.

- Caution**
- To preserve back-up values for RTC and system data during battery replacement, the controller must be powered.
 - Note that disconnecting the battery halts the preservation of back-up values and causes them to be deleted.

1. Remove the battery cover from the controller as shown in the accompanying figure:
 - Press the tab on the module to disengage it.
 - Slide it up to remove it.
2. If you are replacing the battery, remove the battery from its slot on the side of the controller.
3. Insert the battery, ensuring that the polarity is aligned with the polarity marking as shown in the accompanying figure.
4. Replace the battery cover.
5. Dispose of the used battery according to local and national standards and regulations.

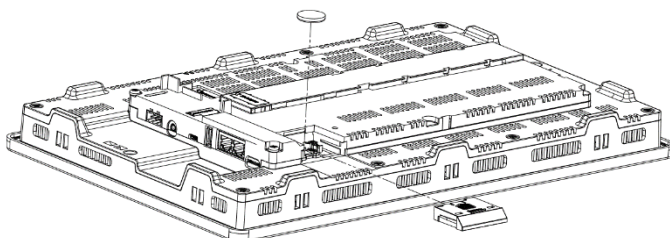
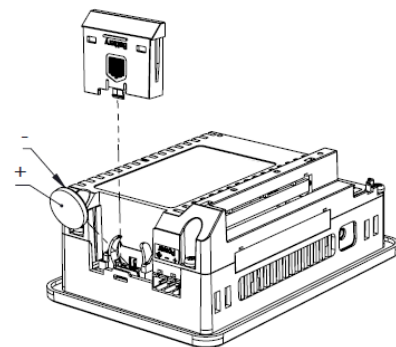

Wiring



- This equipment is designed to operate only at SELV/PELV/Class 2/Limited Power environments.
- All power supplies in the system must include double insulation. Power supply outputs must be rated as SELV/PELV/Class 2/Limited Power.
- Do not connect either the 'Neutral' or 'Line' signal of the 110/220VAC to device's 0V point.
- Do not touch live wires.
- All wiring activities should be performed while power is OFF.
- Use over-current protection, such as a fuse or circuit breaker, to avoid excessive currents into the power supply connection point.
- Unused points should not be connected (unless otherwise specified). Ignoring this directive may damage the device.
- Double-check all wiring before turning on the power supply.

-
- Caution*
- To avoid damaging the wire, use a maximum torque of 0.5 N·m (4.4 in-lb).
 - Do not use tin, solder, or any substance on stripped wire that might cause the wire strand to break.
 - Wire and cable should have a temperature rating of minimum 75°C.
 - Install at maximum distance from high-voltage cables and power equipment.
-

Wiring Procedure

Use crimp terminals for wiring; use 26-12 AWG wire (0.13 mm² –3.31 mm²)

1. Strip the wire to a length of 7±0.5mm (0.250–0.300 inches).
2. Unscrew the terminal to its widest position before inserting a wire.
3. Insert the wire completely into the terminal to ensure a proper connection.
4. Tighten enough to keep the wire from pulling free.

Wiring Guidelines

In order to ensure that the device will operate properly and to avoid electromagnetic interference:

- Use a metal cabinet. Make sure the cabinet and its doors are properly earthed.
- Use wires that are properly sized for the load.
- Use shielded twisted pair cables for wiring High Speed and Analog I/O signals. In either case, do not use the cable shield as a signal common / return path.
- Route each I/O signal with its own dedicated common wire. Connect common wires at their respective common (CM) points at the controller.
- Individually connect each 0V point and each common (CM) point in the system to the power supply 0V terminal, unless otherwise specified.
- Individually connect each functional ground point (⚡) to the earth of the system (preferably to the metal cabinet chassis). Use the shortest and thickest wires possible: less than 1m (3.3') in length, minimum thickness 14 AWG (2 mm²).
- Connect the power supply 0V to the earth of the system.

- Earthing the cables' shield:
 - Connect the cable shield to the earth of the system (preferably to the metal cabinet chassis). Note that the shield must be connected only at one end of the cable; it is recommended to earth the shield at the PLC-side.
 - Keep shield connections as short as possible.
 - Ensure shield continuity when extending shielded cables.

NOTE For detailed information, refer to the document System Wiring Guidelines, located in the Technical Library in the Unitronics' website.

Wiring the Power Supply

The controller requires an external power supply.

- ⚠ In the event of voltage fluctuations or non-conformity to voltage power supply specifications, connect the device to a regulated power supply.

Connect the +V and 0V terminals as shown in the accompanying figure.

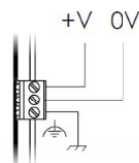

Connecting Ports

- Ethernet CAT-5e shielded cable with RJ45 connector
- USB Device Standard USB cable with Mini-B USB plug (USC-C plug in US15)
- USB Host Standard USB device with Type-A plug

Connecting Audio

- Audio-Out Use 3.5mm stereo audio plug with shielded audio cable
Note that only Pro models support this feature.

Audio Pinout

- 1 Headphone Left Out (Tip)
- 2 Headphone Right Out (Ring)
- 3 Ground (Ring)
- 4 Don't connect (Sleeve)

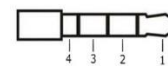

Note that below, the letters "xx" that is used in the model numbers means that the section refers both to B5/C5 and B10/C10 models.

US5-xx-TR22, US5-xx-T24

US5-xx-TR22, US7-xx-TR22, US10-xx-TR22

US7-xx-TR22, US7-xx-T24

US10-xx-TR22, US10-xx-T24

I/O Connection Points

The IOs for these models are arranged in two groups of fifteen points each, as shown in the figures to the right.

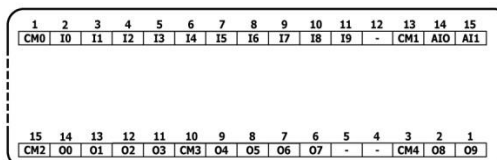

US5-xx-T24, US7-xx-T24, US10-xx-T24

Top group

Input connection points

Bottom group

Output connection points

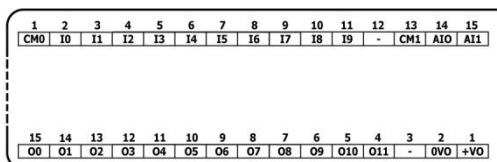

The function of certain I/Os may be adapted via wiring and software settings.

Wiring the Digital Inputs

All 10 digital inputs share the common point CM0. The digital inputs may be wired together as sink or source.

Input wiring, sink

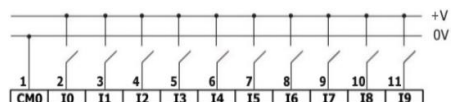

Input wiring, source

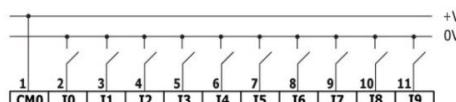

NOTE Use sink input wiring to connect a sourcing (pnp) device. Use source input wiring to connect a sinking (npn) device.

Wiring the Analog Inputs

Both inputs share the common point CM1.

- NOTE**
- The inputs are not isolated.
 - Each input offers two modes: voltage or current. You can set each input independently.
 - The mode is determined by the hardware configuration within the software application.
 - Note that if, for example, you wire the input to current, you must also set it to current in the software application.

Voltage

Differential

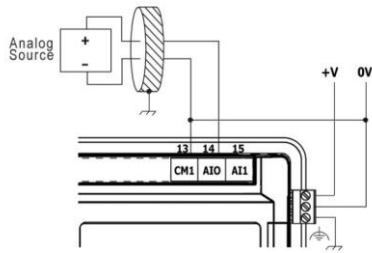

Single-ended

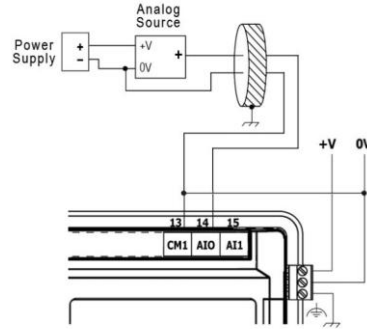

Current

2-wire

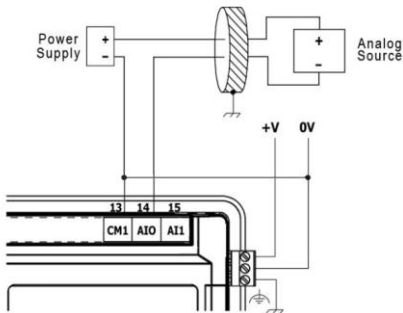

3-wire

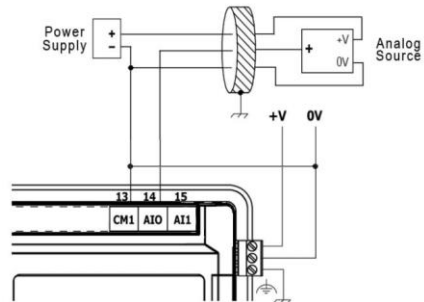

4-wire

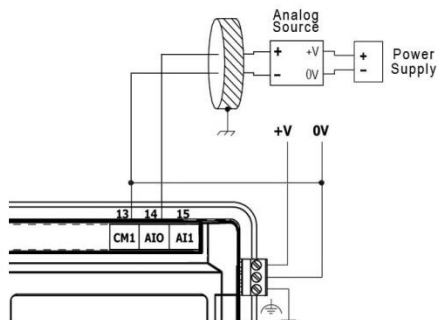

Wiring the Relay Outputs (US5-xx-TR22, US7-xx-TR22, US10-xx-TR22)

- ⚠ To avoid risk of fire or property damage, always use a limited current source or connect a current limiting device in series with the relay contacts

The relay outputs are arranged in two isolated groups:

O0-O3 share the common return CM2.

O4-O7 share the common return CM3.

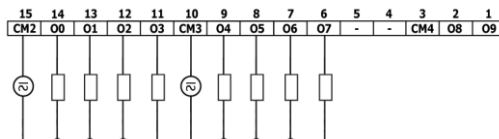

Increasing Contact Life Span

To increase the life span of the relay contacts and protect the controller from potential damage by reverse EMF, connect:

- a clamping diode in parallel with each inductive DC load,
- a RC snubber circuit in parallel with each inductive AC load

DC Load

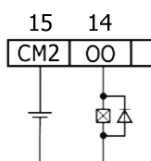

AC Load

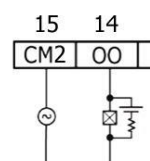

Wiring the Sink Transistor Outputs (US5-xx-TR22, US7-xx-TR22, US10-xx-TR22)

- ⚠ Connect a current limiting device in series with outputs O8 and O9. These outputs are not short-circuit protected.

- Outputs O8 and O9 can independently be configured as either normal digital outputs or as high speed PWM outputs.
- Outputs O8 and O9 share the common point CM4.

Normal Transistor Output

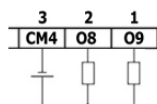

High Speed PWM Output

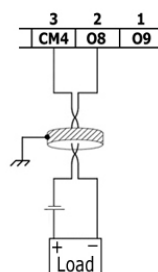

Wiring the Source Transistor Outputs (US5-xx-T24, US7-xx-T24, US10-xx-T24)

Output's power supply

The use of any of the outputs requires an external 24VDC power supply as shown in the accompanying figure.

Outputs

Connect the +VO and 0VO terminals as shown in the accompanying figure.

O0-O11 share common return 0VO.

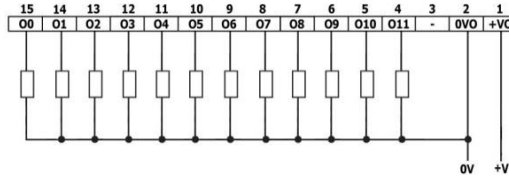

Installing Uni-I/O™ & Uni-COM™ Modules

Refer to the Installation Guides provided with these modules.



- Turn off system power before connecting or disconnecting any modules or devices.
- Use proper precautions to prevent Electro-Static Discharge (ESD).

Uninstalling the Controller

1. Disconnect the power supply.
2. Remove all wiring and disconnect any installed devices according to the device's installation guide.
3. Unscrew and remove the mounting brackets, taking care to support the device to prevent it from falling during this procedure.

The information in this document reflects products at the date of printing. Unitronics reserves the right, subject to all applicable laws, at any time, at its sole discretion, and without notice, to discontinue or change the features, designs, materials and other specifications of its products, and to either permanently or temporarily withdraw any of the foregoing from the market.

All information in this document is provided "as is" without warranty of any kind, either expressed or implied, including but not limited to any implied warranties of merchantability, fitness for a particular purpose, or non-infringement. Unitronics assumes no responsibility for errors or omissions in the information presented in this document. In no event shall Unitronics be liable for any special, incidental, indirect or consequential damages of any kind, or any damages whatsoever arising out of or in connection with the use or performance of this information.

The tradenames, trademarks, logos and service marks presented in this document, including their design, are the property of Unitronics (1989) (R"G) Ltd. or other third parties and you are not permitted to use them without the prior written consent of Unitronics or such third party as may own them

UniStream® Built-in

Technical Specifications

US5-B5-B1, US5-B10-B1, US5-B5-TR22, US5-B10-TR22, US5-B5-T24, US5-B10-T24, US5-C5-B1, US5-C10-B1, US5-C5-TR22, US5-C10-TR22, US5-C5-T24, US5-C10-T24

US7-B5-B1, US7-B10-B1, US7-B5-TR22, US7-B10-TR22, US7-B5-T24, US7-B10-T24, US7-C5-B1, US7-C10-B1, US7-C5-TR22, US7-C10-TR22, US7-C5-T24, US7-C10-T24

US10-B5-B1, US10-B10-B1, US10-B5-TR22, US10-B10-TR22, US10-B5-T24, US10-B10-T24, US10-C5-B1, US10-C10-B1, US10-C5-TR22, US10-C10-TR22, US10-C5-T24, US10-C10-T24

US15-B10-B1, US15-C10-B1

Unitronics' UniStream® Built-in series are PLC+HMI All-in-One programmable controllers that comprise built-in HMI and built-in I/Os. UniStream connects directly to UniCloud, Unitronics' IIoT cloud platform using built-in UniCloud connectivity. More information about UniCloud is available at www.unitronics.cloud.

Model numbers in this document

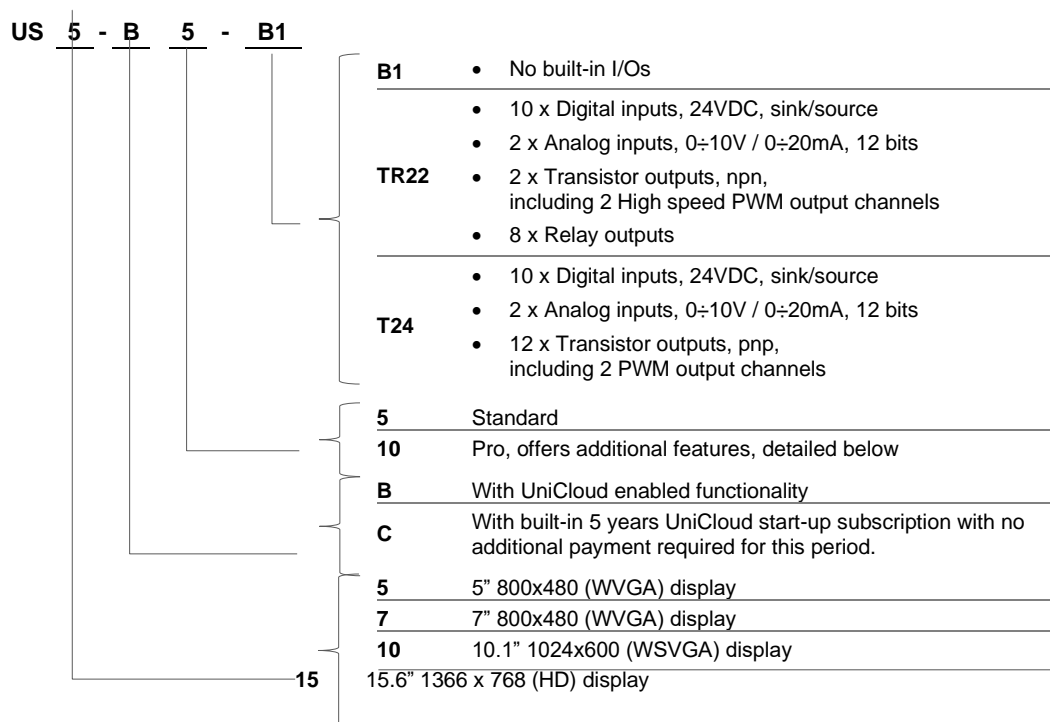

Installation Guides are available in the Unitronics Technical Library at www.unitronicsplc.com.

Power Supply		USx-xx-B1	USx-xx-TR22	USx-xx-T24
Input voltage		12VDC or 24VDC	24VDC	24VDC
Permissible range		10.2VDC to 28.8VDC	20.4VDC to 28.8VDC	20.4VDC to 28.8VDC
Max. current consumption	US5	0.7A@12VDC 0.4A@24VDC	0.44A@24VDC	0.4A@24VDC
	US7	0.79A@12VDC 0.49A@24VDC	0.53A@24VDC	0.49A@24VDC
	US10	0.85A@12VDC 0.52A@24VDC	0.56A@24VDC	0.52A@24VDC
	US15	2.2A@12VDC 1.1A@24VDC	None	None
Isolation		None		

Display	UniStream 5"	UniStream 7"	UniStream 10.1"	UniStream 15.6"
LCD type	TFT			
Backlight type	White LED			
Luminous intensity (brightness)	Typically 350 nits (cd/m ²), at 25°C	Typically 400 nits (cd/m ²), at 25°C	Typically 300 nits (cd/m ²), at 25°C	Typically 400 nits (cd/m ²), at 25°C
Backlight longevity (1)	30k hours			
Resolution (pixels)	800 x 480 (WVGA)		1024 x 600 (WSVGA)	1366 x 768 (HD)
Size	5"	7"	10.1"	15.6"
Viewing area	Width x Height (mm) 108 x 64.8	Width x Height (mm) 154.08 x 85.92	Width x Height (mm) 222.72 x 125.28	Width x Height (mm) 344.23 x 193.53
Color support	65,536 (16bit)			
Surface treatment	Anti-glare			
Touch screen	Resistive Analog			
Actuation force (min)	> 80 g (0.176 lb)			

General	
I/O support	Up to 2,048 I/O points
Built-in I/O	According to model
Local I/O expansion	To add local I/Os, use UAG-CX I/O Expansion Adapters (2). These adapters provide the connection point for standard UniStream Uni-I/O™ modules. You can connect up to 80 I/O modules to a single controller using these adapters. US15 only – Integrate I/O into your system by using UAG-BACK-IOADP adapter, snap onto the panel for an all-in-one configuration.
Remote I/O	Up to 8 UniStream Remote I/O Adapters (URB)
Communication ports	
Built-in COM ports	Specifications are provided below in the section Communications
Add-on Ports	Add up to 3 ports to a single controller using Uni-COM™ UAC-CX Modules (3).

Internal memory	Standard (B5/C5)	Pro (B10/C10)
	RAM: 512MB ROM: 3GB system memory 1GB user memory	RAM: 1GB ROM: 6GB system memory 2GB user memory
Ladder memory	1 MB	

External memory	microSD or microSDHC card Size: up to 32GB, Data Speed: up to 200Mbps
Bit operation	0.13 μ s
Battery	Model: 3V CR2032 Lithium battery ⁽⁴⁾ Battery lifetime: 4 years typical, at 25°C Battery Low detection and indication (via the HMI and via System Tag).

Audio (Pro B10/C10 models only)

Bit Rate	192kbps
Audio compatibility	Stereo MP3 files
Interface	3.5mm Audio-out jack - use shielded audio cable of up to 3 m (9.84 ft)
Impedance	16 Ω , 32 Ω
Isolation	None

Video (Pro B10/C10 models only)

Supported Formats	MPEG-4 Visual , AVC/H.264
-------------------	---------------------------

Communication (Built-in Ports)	US5, US7, US10	US15
Ethernet port		
Number of ports	1	2
Port type	10/100 Base-T (RJ45)	
Auto crossover	Yes	
Auto negotiation	Yes	
Isolation voltage	500VAC for 1 minute	
Cable	Shielded CAT5e cable, up to 100 m (328 ft)	
USB device		
Port type	Mini-B	USB-C
Data rate	USB 2.0 (480Mbps)	
Isolation	None	
Cable	USB 2.0 compliant; < 3 m (9.84 ft)	
USB host		
Over current protection	Yes	

Digital Inputs (T24,TR22 models)

Number of inputs	10
Type	Sink or Source
Isolation voltage	
Input to bus	500VAC for 1 minute
Input to input	None
Nominal voltage	24VDC @ 6mA
Input voltage	
Sink/Source	On state: 15-30VDC, 4mA min. Off state: 0-5VDC, 1mA max.
Nominal impedance	4k Ω
Filter	6ms typical

Analog Inputs (T24,TR22 models)

Number of inputs	2		
Input range (6) (7)	Input Type	Nominal Values	Over-range Values *
	0 \div 10VDC	0 \leq Vin \leq 10VDC	10 < Vin \leq 10.15VDC

	0 ÷ 20mA	0 ≤ I _{in} ≤ 20mA	20 < I _{in} ≤ 20.3mA		
	* Overflow ⁽⁸⁾ is declared when an input value exceeds the Over-range boundary.				
Absolute maximum rating	±30V (Voltage), ±30mA (Current)				
Isolation	None				
Conversion method	Successive approximation				
Resolution	12 bits				
Accuracy (25°C / -20°C to 55°C)	±0.3% / ±0.9% of full scale				
Input impedance	541kΩ (Voltage), 248Ω (Current)				
Noise rejection	10Hz, 50Hz, 60Hz, 400Hz				
Step response ⁽⁹⁾ (0 to 100% of final value)	Smoothing	Noise Rejection Frequency			
		400Hz	60Hz	50Hz	10Hz
	None	2.7ms	16.86ms	20.2ms	100.2ms
	Weak	10.2ms	66.86ms	80.2ms	400.2ms
	Medium	20.2ms	133.53ms	160.2ms	800.2ms
Strong	40.2ms	266.86ms	320.2ms	1600.2ms	

Update time ⁽⁹⁾	Noise Rejection Frequency	Update Time
	400Hz	5ms
	60Hz	4.17ms
	50Hz	5ms
	10Hz	10ms
Operational signal range (signal + common mode)	Voltage mode – A _{ix} : -1V ÷ 10.5V ; CM1: -1V ÷ 0.5V Current mode – A _{ix} : -1V ÷ 5.5V ; CM1: -1V ÷ 0.5V (x=0 or 1)	
Cable	Shielded twisted pair	
Diagnostics ⁽⁸⁾	Analog input overflow	

Relay Outputs (USx-xx-TR22)

Number of outputs	8 (O0 to O7)
Output type	Relay, SPST-NO (Form A)
Isolation groups	Two groups of 4 outputs each
Isolation voltage	
Group to bus	1,500VAC for 1 minute
Group to group	1,500VAC for 1 minute
Output to output within group	None
Current	2A maximum per output (Resistive load)
Voltage	250VAC / 30VDC maximum
Minimum load	1mA, 5VDC
Switching time	10ms maximum
Short-circuit protection	None
Life expectancy ⁽¹⁰⁾	100k operations at maximum load

Sink Transistor Outputs (USx-xx-TR22)

Number of outputs	2 (O8 and O9)
Output type	Transistor, Sink
Isolation	
Output to bus	1,500VAC for 1 minute
Output to output	None
Current	50mA max. per output
Voltage	Nominal: 24VDC Range: 3.5V to 28.8VDC
On state voltage drop	1V max
Off state leakage current	10 μ A max
Switching times	Turn-on: 1.6 μ s max. (4k Ω load, 24V) Turn-off: 13.4 μ s max. (4k Ω load, 24V)
High speed outputs	
PWM Frequency	0.3Hz min. 30kHz max. (4k Ω load)
Cable	Shielded twisted pair

Source Transistor Outputs (USx-xx-T24)

Number of outputs	12
Output type	Transistor, Source (pnp)
Isolation voltage	
Output to bus	500VAC for 1 minute
Output to output	None
Outputs power supply to bus	500VAC for 1 minute
Outputs power supply to output	None
Current	0.5A maximum per output
Voltage	See Source Transistor Outputs Power Supply specification below
ON state voltage drop	0.5V maximum
OFF state leakage current	10 μ A maximum
Switching times	Turn-on: 80 μ s maximum, Turn-off: 155 μ s maximum (Load resistance < 4k Ω)
PWM Frequency ⁽¹¹⁾	O0, O1: 3kHz max. (Load resistance < 4k Ω)
Short-circuit protection	Yes

Source Transistor Outputs Power Supply (USx-xx-T24)

Nominal operating voltage	24VDC
Operating voltage	20.4 – 28.8VDC
Maximum current consumption	30mA@24VDC Current consumption does not include load current

Environmental	US5, US7, US10	US15
Protection	Front face: IP66, NEMA 4X Rear side: IP20, NEMA1	
Operating temperature	-20°C to 55°C (-4°F to 131°F)	0°C to 50°C (32°F to 122°F)
Storage temperature	-30°C to 70°C (-22°F to 158°F)	-20°C to 60°C (-4°F to 140°F)
Relative Humidity (RH)	5% to 95% (non-condensing)	
Operating Altitude	2,000 m (6,562 ft)	
Shock	IEC 60068-2-27, 15G, 11ms duration	
Vibration	IEC 60068-2-6, 5Hz to 8.4Hz, 3.5mm constant amplitude, 8.4Hz to 150Hz, 1G acceleration	

Dimensions		
	Weight	Size
US5-xx-B1	0.31 Kg (0.68 lb)	Refer to the images on page 7
US5-xx-TR22	0.37 Kg (0.81 lb)	
US5-xx-T24	0.35 Kg (0.77 lb)	
US7-xx-B1	0.62 Kg (1.36 lb)	Refer to the images on page 8
US7-xx-TR22	0.68 Kg (1.5 lb)	
US7-xx-T24	0.68 Kg (1.5 lb)	
US10-xx-B1	1.02 Kg (2.25 lb)	Refer to the images on page 8
US10-xx-TR22	1.08 Kg (2.38 lb)	
US10-xx-T24	1.08 Kg (2.38 lb)	
US15-xx-B1	2.68Kg (5.9 lb)	Refer to the images on page 9

UniStream 5"

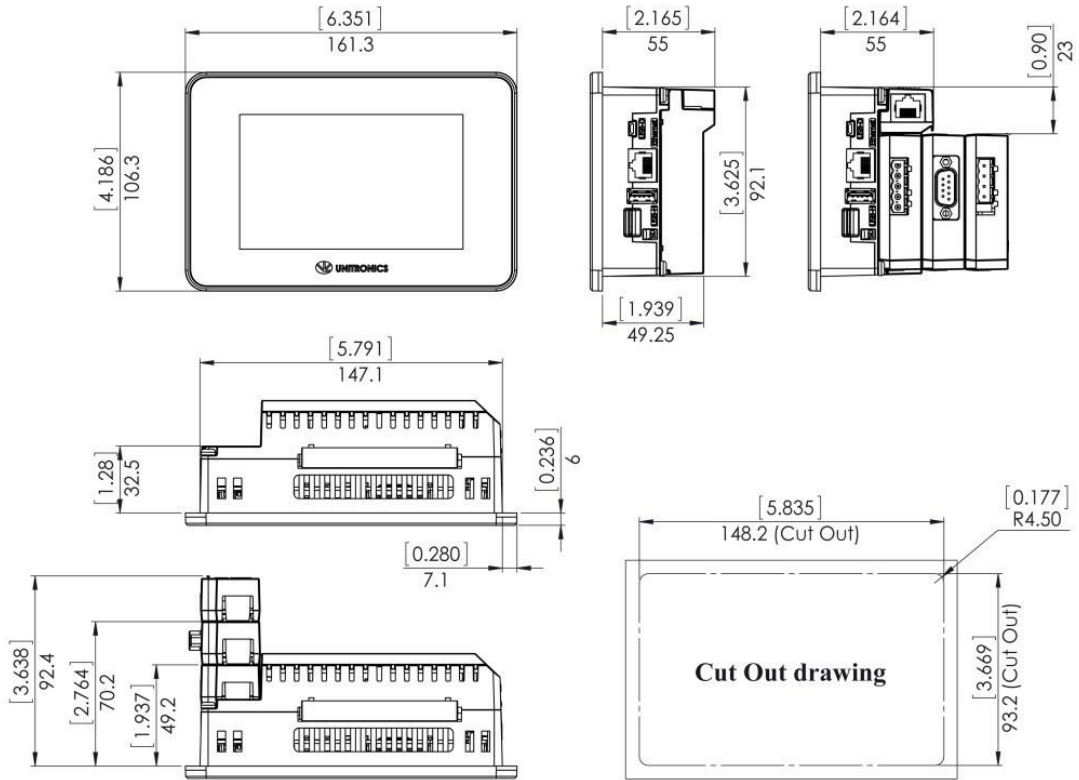

UniStream 7"

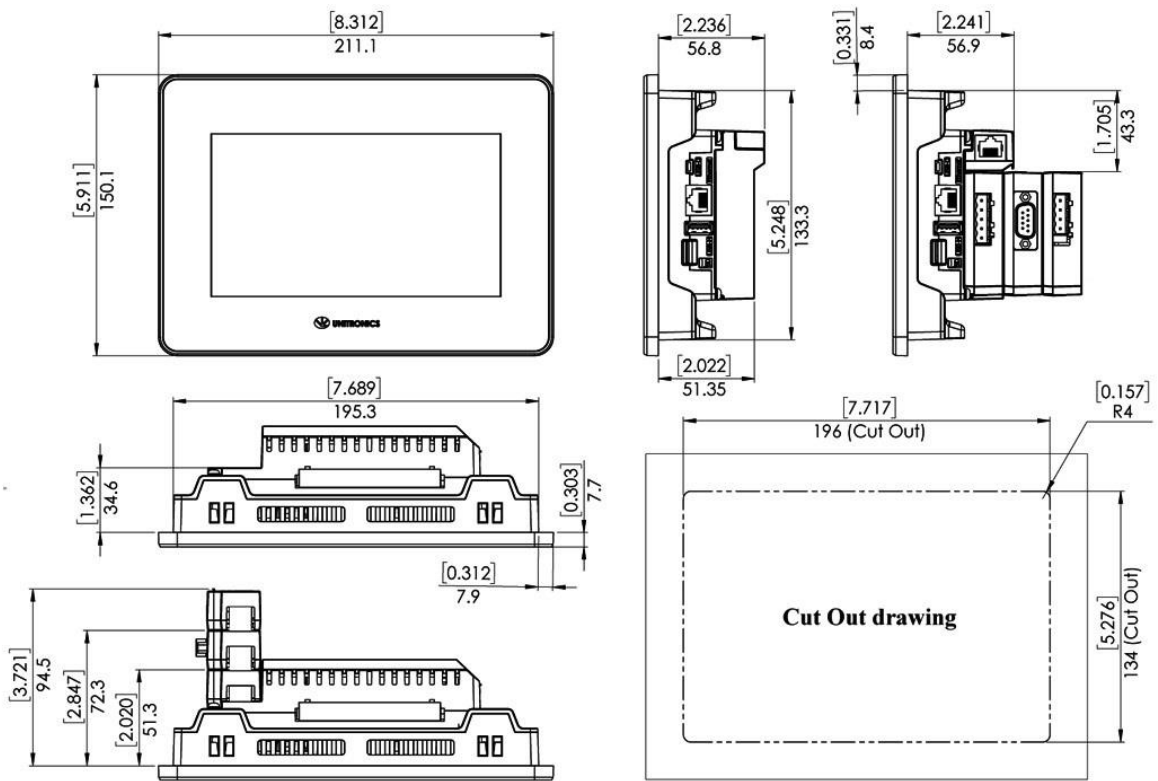

UniStream 10.1"

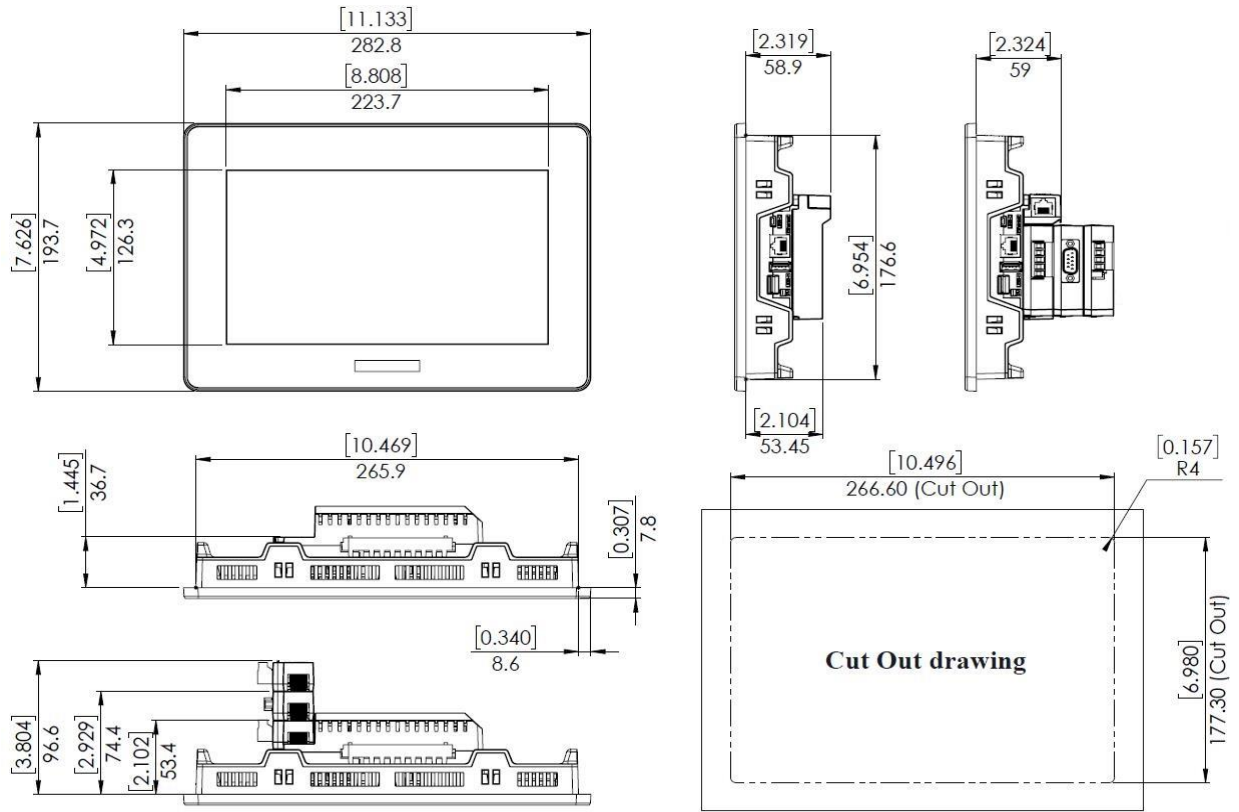

UniStream 15.6"

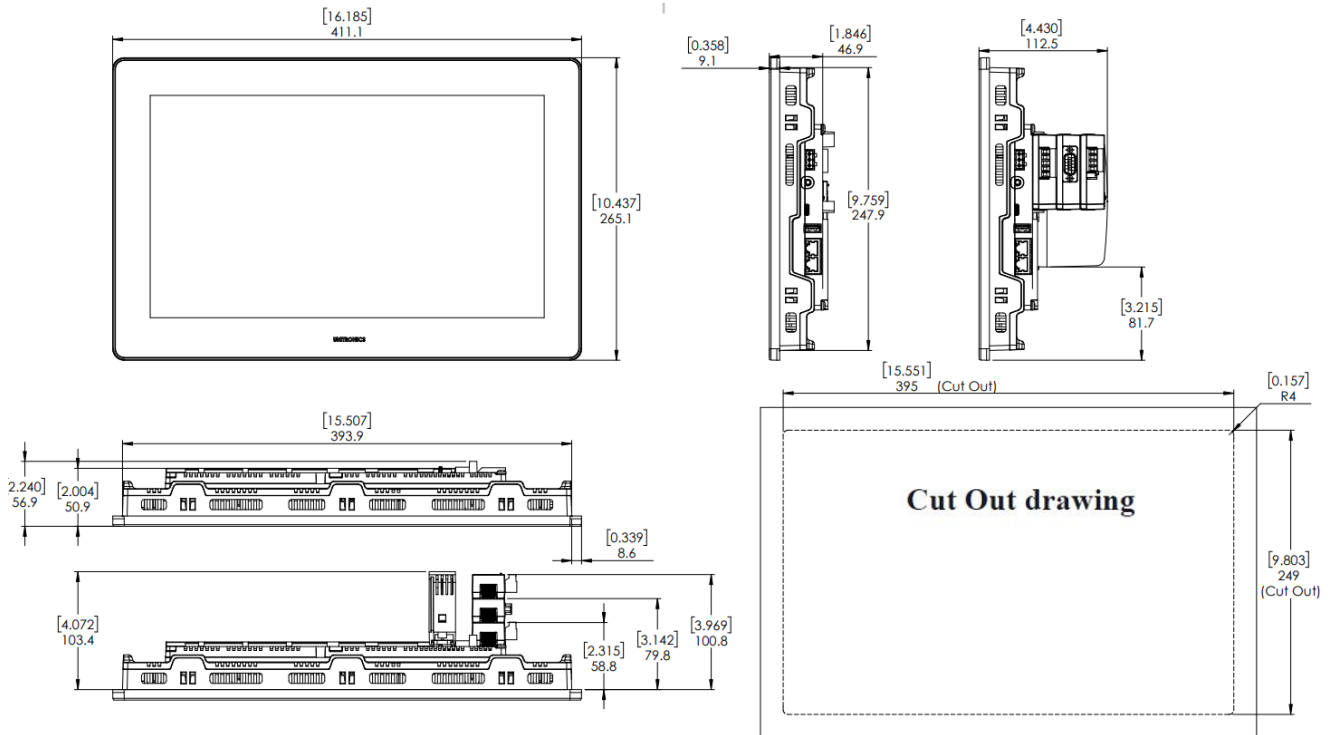

Notes:

1. The HMI panel's backlight longevity is the typical operating time after which the brightness drops to 50% of its original level.
2. UAG-CX Expansion Adapter Kits comprise a Base unit, an End unit, and a connecting cable. You plug the Base Unit into the controller's I/O Expansion Jack and connect standard UniStream Uni-I/O™ modules. For more information, refer to the product's installation guide and technical specifications.
3. Uni-COM™ CX modules plug directly into the Uni-COM™ CX Module Jack on the back of the controller. UAC-CX modules may be installed in the following configurations:
 - If a module comprising a serial port is snapped directly into to the back of UniStream, it may be followed only by another serial module, for a total of 2.
 - If your configuration includes a CANbus module, it must be snapped directly to the back of UniStream. The CANbus module may be followed by up to two serial modules, for a total of 3.
 For more information, refer to the product's installation guide and technical specifications.
4. When replacing the unit's battery, make sure that the new one has environmental specifications that are similar or better than the one specified in this document.
5. The USB device port is used to connect the device to a PC.
6. The 4-20mA input option is implemented using 0-20mA input range.
7. The analog inputs measure values that are slightly higher than the nominal input range (Input Over-range).
Note that when the input overflow occurs, it is indicated in the corresponding I/O Status tag while the input value is registered as the maximum permissible value. For example, if the specified input range is 0 ÷ 10V, the Over-range values can reach up to 10.15V, and any input voltage higher than that will still register as 10.15V while the Overflow system tag is turned on.
8. The diagnostics results are indicated in the system tags and can be observed through the UniApps™ or the online state of the UniLogic™.
9. Step response and update time are independent of the number of channels that are used.
10. Life expectancy of the relay contacts depends on the application that they are used in. The product's installation guide provides procedures for using the contacts with long cables or with inductive loads.
11. Outputs O0 and O1 can be configured as either normal digital outputs or as PWM outputs. PWM outputs specifications apply only when outputs are configured as PWM outputs.

The information in this document reflects products at the date of printing. Unitronics reserves the right, subject to all applicable laws, at any time, at its sole discretion, and without notice, to discontinue or change the features, designs, materials and other specifications of its products, and to either permanently or temporarily withdraw any of the forgoing from the market.

All information in this document is provided "as is" without warranty of any kind, either expressed or implied, including but not limited to any implied warranties of merchantability, fitness for a particular purpose, or non-infringement. Unitronics assumes no responsibility for errors or omissions in the information presented in this document. In no event shall Unitronics be liable for any special, incidental, indirect or consequential damages of any kind, or any damages whatsoever arising out of or in connection with the use or performance of this information.

The tradenames, trademarks, logos and service marks presented in this document, including their design, are the property of Unitronics (1989) (R"G) Ltd. or other third parties and you are not permitted to use them without the prior written consent of Unitronics or such third party as may own them.