



V200-19-ET2 Ethernet COM Port



The V200-19-ET2 Ethernet COM Port is a communication module that enables you to install an Ethernet COM port into compatible Vision controllers. The Ethernet port enables you to implement communications via TCP/IP, such as MODBUS over TCP.

- Before using this product, it is the responsibility of the user to read and understand this document and any accompanying documentation.
- All examples and diagrams shown herein are intended to aid understanding, and do not guarantee operation. Unitronics accepts no responsibility for actual use of this product based on these examples.
- Please dispose of this product in accordance with local and national standards and regulations.
- Only qualified service personnel should open this device or carry out repairs.

User safety and equipment protection guidelines

This document is intended to aid trained and competent personnel in the installation of this equipment as defined by the European directives for machinery, low voltage, and EMC. Only a technician or engineer trained in the local and national electrical standards should perform tasks associated with the device's electrical wiring.

Symbols are used to highlight information relating to the user's personal safety and equipment protection throughout this document. When these symbols appear, the associated information must be read carefully and understood fully.

| Symbol | Meaning | Description |
|---|---------|---|
|  | Danger | The identified danger causes physical and property damage. |
|  | Warning | The identified danger can cause physical and property damage. |
| <i>Caution</i> | Caution | Use caution. |



- Failure to comply with appropriate safety guidelines can result in severe personal injury or property damage. Always exercise proper caution when working with electrical equipment.



- Check the user program before running it.
- Do not attempt to use this device with parameters that exceed permissible levels.
- Install an external circuit breaker and take appropriate safety measures against short-circuiting in external wiring.

Software & Hardware compatibility

The V200-19-ET2 hardware is backward compatible with existing and new Vision series PLCs as listed in the table below.

The V200-19-ET2 is supported by the following (or higher) software versions:

| Vision PLC | Hardware Compatibility | Minimum Operating System Software version | Minimum BOOT version | Minimum VisiLogic version |
|--------------------------|------------------------|---|----------------------|---------------------------|
| V230/V260/V280/V290/V530 | ✓ | 5.4.55 (Released 1/2015) | Not relevant | 9.7.41 |
| V560/V570 | ✓ | 3.3.0 (Released 11/2010) | 2.2.04 | 9.0.0 |
| V1040 and V1210 | ✓ | 3.3.0 (Released 11/2010) | 2.2.04 | 9.0.0 |

Installation Instructions

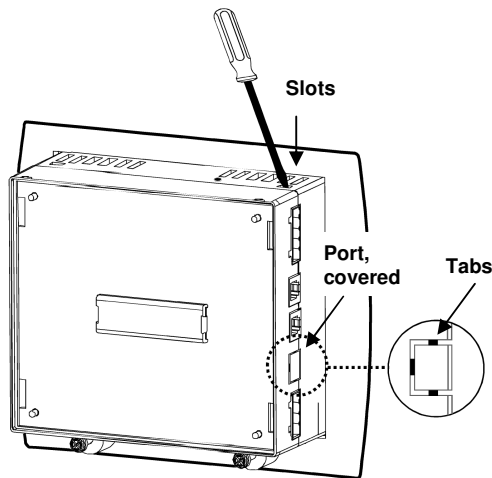

Figure 1. Opening the Controller

1. Turn power off before opening the controller.
2. If the controller has an installed Snap-in I/O module, remove it. Instructions are given in 'Removing a Snap-in Module' in the Vision User Guide.
3. Open the OPLC by inserting a screwdriver into the slots located on the sides of the controller as shown, then carefully prying the cover off.
4. The port's location is covered by plastic. Remove the plastic covering using a razor cutter to cut through the tabs shown in Figure 1.
5. Locate the J1 and J3 connectors shown in Figure 2.
6. Install the module by placing the module's connectors onto the controller card as shown in Figure 3. In order to avoid bending the connector pins, exercise appropriate caution. Make sure that the connection is secure.
7. Close the controller by snapping the plastic cover back in its place. If the card is placed correctly, the cover will snap on easily.
8. If required, reinstall the Snap-in Module.

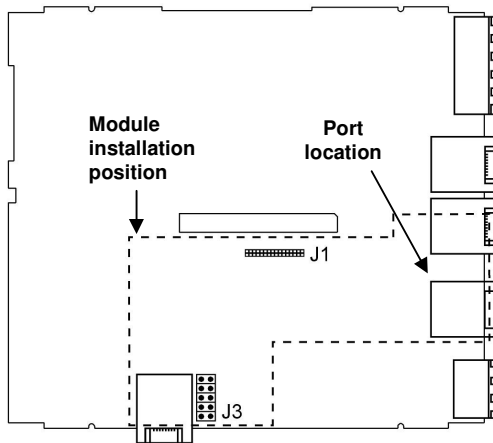

Figure 2. Controller, Main PCB Board

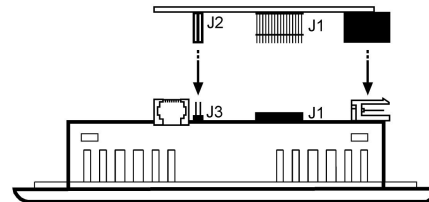

Figure 3. Installing the Module

V1040/V1210

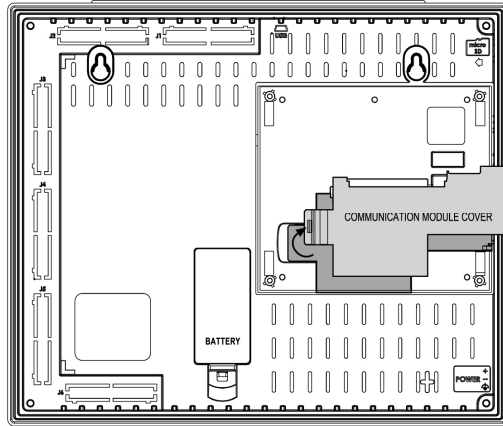

Figure 4. Communication Module Cover

1. If the I/O connector cap is in place, remove it.
2. Open the communication module cover shown in Figure 4 .
3. The port's location, COM 3, is covered by plastic. Remove the plastic covering using a razor cutter to cut through the tabs shown in Figure 1.
4. Install the module by lining up the module's connectors with those in the controller, and push it into place. See Notes below.
5. Close the controller by snapping the plastic cover back in its place. If the card is placed correctly, the cover will snap on easily.
6. If required, reinstall the Snap-in Module. If there is no Snap-in Module, replace the I/O connector cap.

Note

- Your card was supplied with a single screw, and you are installing it in a V1040/V1210, after pushing the module into place, screw it into the hole that is located near the port.

Wiring



- Do not touch live wires.



- Unused pins should not be connected. Ignoring this directive may damage the device.
- Double-check all wiring before turning on the power supply.

Ethernet Wiring—General

- Use CAT5 STP (shielded twisted pair) cable.
- Set up the network in accordance with the star configuration shown below.

RJ45 Connector Pin-out

| Pin Number | Function | <p>Pin#1</p> <p>Metal Lining</p> |
|------------|-------------------------------|----------------------------------|
| 1 | T+ = Positive transmit signal | |
| 2 | T- = Negative transmit signal | |
| 3 | R+ = Positive receive signal | |
| 6 | R- = Negative receive signal | |

Topology

Star topology is recommended.

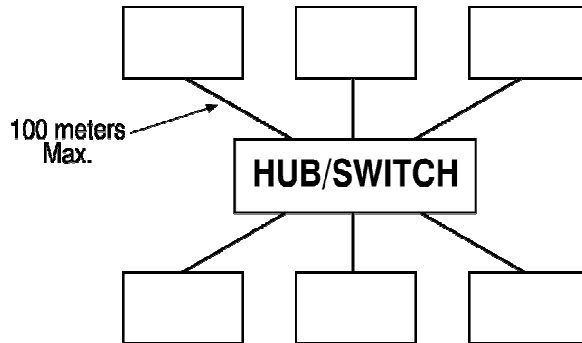

Ethernet Connections

| Controller to hub/switch connection | | | | |
|-------------------------------------|----------|---|------------|----------|
| Controller | | | Hub/Switch | |
| Pin # | Function | | Pin # | Function |
| 1 | T+ | → | 1 | T+ |
| 2 | T- | → | 2 | T- |
| 3 | R+ | ← | 3 | R+ |
| 6 | R- | ← | 6 | R- |

| Controller to controller connection | | | | |
|-------------------------------------|----------|---|------------|----------|
| Controller | | | Controller | |
| Pin # | Function | | Pin # | Function |
| 1 | T+ | → | 3 | R+ |
| 2 | T- | → | 6 | R- |
| 3 | R+ | ← | 1 | T+ |
| 6 | R- | ← | 2 | T- |

V200-19-ET2 Technical Specifications

| | |
|--------------------|--|
| Transmission speed | 10/100Mbps |
| Network topology | Star, based on external hub/switch |
| Cable type | Category 5 STP (shielded twisted pair) is recommended; UTP (unshielded twisted pair) may also be used |
| Connector type | RJ45 |
| Drop line length | Up to 100 meters, controller to hub/switch or controller to controller. |

The information in this document reflects products at the date of printing. Unitronics reserves the right, subject to all applicable laws, at any time, at its sole discretion, and without notice, to discontinue or change the features, designs, materials and other specifications of its products, and to either permanently or temporarily withdraw any of the foregoing from the market. All information in this document is provided "as is" without warranty of any kind, either expressed or implied, including but not limited to any implied warranties of merchantability, fitness for a particular purpose, or non-infringement. Unitronics assumes no responsibility for errors or omissions in the information presented in this document. In no event shall Unitronics be liable for any special, incidental, indirect or consequential damages of any kind, or any damages whatsoever arising out of or in connection with the use or performance of this information.

The tradenames, trademarks, logos and service marks presented in this document, including their design, are the property of Unitronics (1989) (R'G) Ltd. or other third parties and you are not permitted to use them without the prior written consent of Unitronics or such third party as may own them.

V200-19-RS4, V200-19-RS4-X RS485/232 COM Port

V200-19-RS4, V200-19-RS4-X are communication modules that enable you to install compatible Vision controllers with an additional COM port, COM 3. The port may be adapted to either the RS232 or the RS485 standard, via jumpers located on the modules and with the appropriate VisiLogic program settings.

Note that the modules are identical except for isolation:

- V200-19-RS4 is **not** isolated
- V200-19-RS4-X is **is** isolated

Installation instructions begin on page 3.

For specific information on RS485/232 networking, refer to the controller's user guides and VisiLogic's Help file.

Component identification

| | |
|---|------------------------------------|
| 1 | J1 connector, plugs into PLC board |
| 2 | RJ11 connector * |
| 3 | RS485/232 jumpers |
| 4 | Termination jumpers |

* Older versions of this module offered an RJ45 connector.

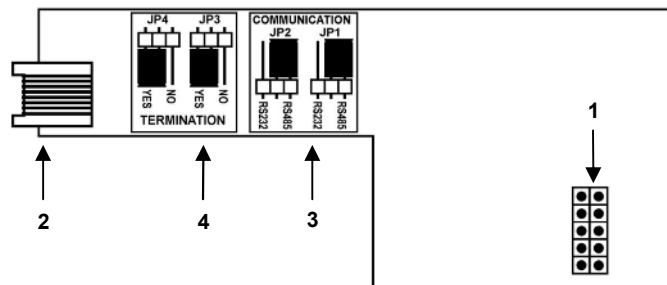

Module V200-19-RS4/V200-19-RS4-X

User safety and equipment protection guidelines

This document is intended to aid trained and competent personnel in the installation of this equipment as defined by the European directives for machinery, low voltage and EMC. Only a technician or engineer trained in the local and national electrical standards should perform tasks associated with the electrical wiring of this device.

- Under no circumstances will Unitronics be liable or responsible for any consequential damage that may arise as a result of installation or use of this equipment, and is not responsible for problems resulting from improper or irresponsible use of this device.
- All examples and diagrams shown in the manual are intended to aid understanding. They do not guarantee operation.
- Unitronics accepts no responsibility for actual use of this product based on these examples.
- Only qualified service personnel should open this device or carry out repairs.
- Please dispose of this product in accordance with local and national standards and regulations.



- Turn off power before making communication connections.
- Check the user program before running it.
- Do not attempt to use this device with voltage exceeding permissible levels.
- Install an external circuit breaker and take appropriate safety measures against short-circuiting in external wiring.
- Do not connect the device directly to a telephone or telephone line.
- The V200-19-RS4 RJ-11 type serial port is not isolated; note that communication signals are related to the controller's 0V; this is the same 0V used by the power supply.
- Ports must always be used with an appropriate adapter.

V200-19-RS4, V200-19-RS4-X RS485/232 COM Port



- Failure to comply with appropriate safety guidelines can result in severe personal injury or property damage. Always exercise proper caution when working with electrical equipment.



- Do not touch live wires.
- Double-check all the wiring before turning on the power supply.

RS232

RS232 Connector Pin-out

| Pin Number | Function |
|------------|--------------|
| 1 | DTR signal |
| 2 | 0V reference |
| 3 | TxD signal |
| 4 | RxD signal |
| 5 | 0V reference |
| 6 | DSR signal |

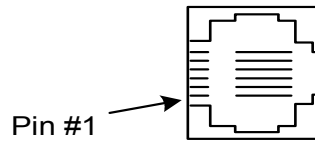

Note that standard programming cables do not provide connection points for pins 1 and 6.

In addition, note that when a port is adapted to RS485, Pin 1 (DTR) is used for signal A, and Pin 6 (DSR) signal is used for signal B as shown in the RS485 pinout.

RS485 Wiring

Note that when a port is set to RS485, you can switch between end devices using either RS232 and RS485 without changing jumper settings. To enable you to do this, do not use flow control signals DTR and DSR.



- Note that the V200-19-RS4 port is not isolated. If the controller is used with a non-isolated external device, avoid potential voltage that exceeds $\pm 10V$. To avoid damaging the system, all non-isolated device ports should relate to the same ground signal.

Caution

- Use shielded, twisted pair cables.
- Minimize the stub (drop) length leading from each device to the bus.
- Ideally, the main cable should be run in and out of the network device.
- Do not cross positive (A) and negative (B) signals. Positive terminals must be wired to positive, and negative terminals to negative.

RS485 Connector Pin-out

| Pin Number | Function |
|------------|----------------|
| 1 | A signal (+) |
| 2 | (RS232 signal) |
| 3 | (RS232 signal) |
| 4 | (RS232 signal) |
| 5 | (RS232 signal) |
| 6 | B signal (-) |

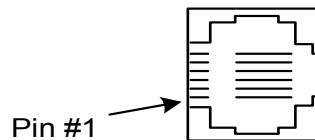

RS485 Network Termination Settings

The jumper settings shown below determine whether the controller can function as an end device in a RS485 network. Note that the factory default setting is ON. If the OPLC is not a network end device, set both jumpers to OFF.

RS232/RS485 Jumper Settings

The tables below show how to set a specific jumper to change the functionality of the port. To open the controller and access the jumpers, refer to the installation instructions below.

RS232/RS485 Jumper Settings

| | | |
|------------|-------|-------|
| To use as: | JP2 | JP1 |
| RS232 | RS232 | RS232 |
| RS485* | RS485 | RS485 |

RS485 Termination Settings

| | | |
|-------------|-----|-----|
| Termination | JP4 | JP3 |
| ON* | Yes | Yes |
| OFF | No | No |

* Default factory setting.

Installation Instructions

- Turn power off before opening the controller.
- If the controller has an installed Snap-in I/O module, remove it. Instructions are given in 'Removing a Snap-in Module' in your Vision model's Installation Guide.
- If the controller does not comprise a Snap-in I/O Module, ensure that the I/O connector cap is in place.

V2xx, V5xx

Note that the V2xx is shown for representational purposes.

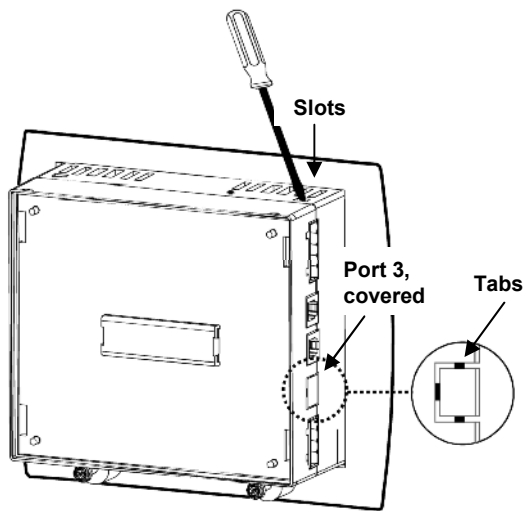

Figure 1. Opening the Controller

1. Open the OPLC according to the instructions given in your Vision model's Installation Guide.
2. The port's location, COM 3, is covered by plastic. Remove the plastic covering using a razor cutter to cut through the tabs shown in Figure 1.
3. Locate the J3 connector shown in Figure 2.
4. Install the module by placing the J1 connector (female) of the module onto the J3 connector (male) on the controller card as shown in Figure 3. Make sure that the connection is secure.
5. Close the controller by snapping the plastic cover back in its place. If the card is placed correctly, the cover will snap on easily.
6. If required, reinstall the Snap-in Module.

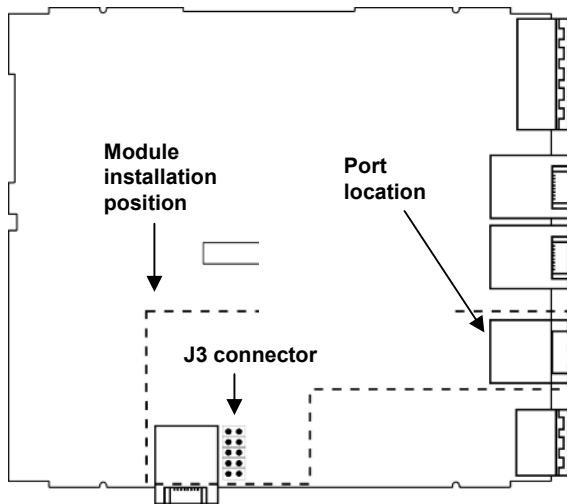

Figure 2. Controller, Main PCB Board

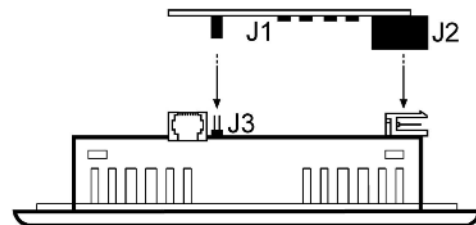

Figure 3. Installing the Module

V1040

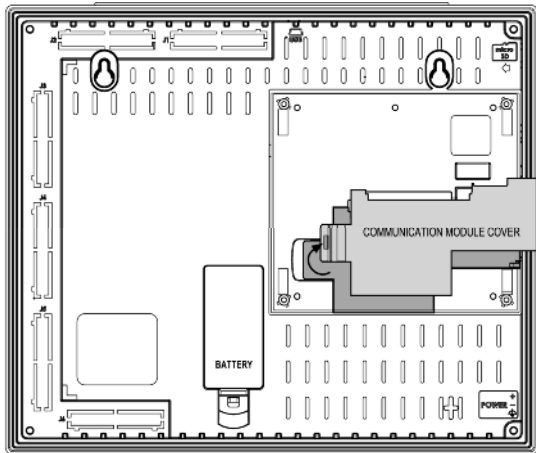

Figure 4. Communication Module Cover

1. If the I/O connector cap is in place, remove it.
2. Open the communication module cover shown in Figure 4 .
3. The port's location, COM 3, is covered by plastic. Remove the plastic covering using a razor cutter to cut through the tabs shown in Figure 1.
4. Install the module by lining up the module's connectors with those in the controller, and push it into place. See Notes below.
5. Close the controller by snapping the plastic cover back in its place. If the card is placed correctly, the cover will snap on easily.
6. If required, reinstall the Snap-in Module. If there is no Snap-in Module, replace the I/O connector cap.

Notes

- If your card was supplied with a single screw, and you are installing it in a V1040, after pushing the module into place, screw it into the hole that is located near the port.
- If your card was not supplied with a screw, check the revision number. Revisions previous to V200-19-RS4/X Rev B did not include a screw, and none is required.

Caution In this case, **do not fasten the module with a screw.**

Technical Specifications

Weight

| | |
|---------------|---------------|
| V200-19-RS4 | 18g (0.63 oz) |
| V200-19-RS4-X | 21g (0.74 oz) |

Environmental

| | |
|------------------------|----------------------------|
| Operating temperature | 0° to 50°C (32 to 122°F) |
| Storage temperature | -20° to 60°C (-4 to 140°F) |
| Relative Humidity (RH) | 5% to 95% (non-condensing) |

Isolation

| | |
|---------------|-----|
| V200-19-RS4 | No |
| V200-19-RS4-X | Yes |

RS232 Port Specifications

| | |
|----------------|------|
| Voltage limits | ±20V |
|----------------|------|

RS485 Port Specifications

| | |
|---------------|---|
| Input Voltage | -7 to +12V differential max. |
| Cable type | Shielded twisted pair, in compliance with EIA RS485 |
| Cable length | 1200m maximum (4000 feet) |
| Baud rate | 300– 115,200 bps |
| Nodes | Up to 32 |

The information in this document reflects products at the date of printing. Unitronics reserves the right, subject to all applicable laws, at any time, at its sole discretion, and without notice, to discontinue or change the features, designs, materials and other specifications of its products, and to either permanently or temporarily withdraw any of the foregoing from the market.

All information in this document is provided "as is" without warranty of any kind, either expressed or implied, including but not limited to any implied warranties of merchantability, fitness for a particular purpose, or non-infringement. Unitronics assumes no responsibility for errors or omissions in the information presented in this document. In no event shall Unitronics be liable for any special, incidental, indirect or consequential damages of any kind, or any damages whatsoever arising out of or in connection with the use or performance of this information.

The tradenames, trademarks, logos and service marks presented in this document, including their design, are the property of Unitronics (1989) (R®) Ltd. or other third parties and you are not permitted to use them without the prior written consent of Unitronics or such third party as may own them.

DSP-V200-RS4-X 11-10