

Super-mini Signal Conditioners Mini-M Series

CT TRANSMITTER

(Average sensing, RMS calibrated)

Functions & Features

- Converts alternating current from a current transformer into a standard process signal
- Minimum ripple
- Rerouted input signal does not pass through the base socket in order to protect it from melting caused by rush current of a motor
- CT Protector provided for open-circuit protection

Typical Applications

- Centralized monitoring and control of motors, pumps or heaters by DCS
- Monitoring power line and power supply current

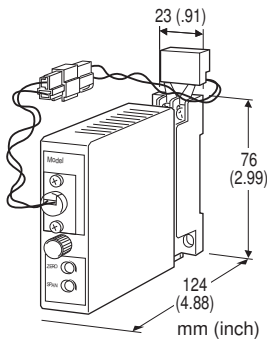

MODEL: M2CA-[1][2]-[3][4]

ORDERING INFORMATION

- Code number: M2CA-[1][2]-[3][4]

Specify a code from below for each [1] through [4].

- (e.g. M2CA-5A-M2/CE/Q)
- Special output range (For codes Z & 0)
- Specify the specification for option code /Q (e.g. /C01/S01)

[1] INPUT (sine wave)

Current

- 1: 0 - 1 A AC
- 5: 0 - 5 A AC

[2] OUTPUT

Current

- A: 4 - 20 mA DC (Load resistance 750 Ω max.)
- B: 2 - 10 mA DC (Load resistance 1500 Ω max.)
- C: 1 - 5 mA DC (Load resistance 3000 Ω max.)

- D: 0 - 20 mA DC (Load resistance 750 Ω max.)
- E: 0 - 16 mA DC (Load resistance 900 Ω max.)
- F: 0 - 10 mA DC (Load resistance 1500 Ω max.)
- G: 0 - 1 mA DC (Load resistance 15 kΩ max.)
- Z: Specify current (See OUTPUT SPECIFICATIONS)

Voltage

- 1: 0 - 10 mV DC (Load resistance 10 kΩ min.)
- 2: 0 - 100 mV DC (Load resistance 100 kΩ min.)
- 3: 0 - 1 V DC (Load resistance 1000 Ω min.)
- 4: 0 - 10 V DC (Load resistance 10 kΩ min.)
- 5: 0 - 5 V DC (Load resistance 5000 Ω min.)
- 6: 1 - 5 V DC (Load resistance 5000 Ω min.)
- 0: Specify voltage (See OUTPUT SPECIFICATIONS)

[3] POWER INPUT

AC Power

- M: 85 - 264 V AC (Operational voltage range 85 - 264 V, 47 - 66 Hz)

(Select '/N' for 'Standards & Approvals' code.)

- M2: 100 - 240 V AC (Operational voltage range 85 - 264 V, 47 - 66 Hz)

(90 - 264 V for UL)

DC Power

- R: 24 V DC (Operational voltage range 24 V ±10 %, ripple 10 %p-p max.)

- R2: 11 - 27 V DC (Operational voltage range 11 - 27 V, ripple 10 %p-p max.)

(Select '/N' for 'Standards & Approvals' code.)

- P: 110 V DC (Operational voltage range 85 - 150 V, ripple 10 %p-p max.)

(110 V ±10 % for UL)

[4] OPTIONS (multiple selections)

Standards & Approvals (must be specified)

- /N: Without CE or UL
- /CE: CE marking
- /UL: UL approval, CE marking

Other Options

- blank: none
- /Q: Option other than the above (specify the specification)

SPECIFICATIONS OF OPTION: Q (multiple selections)

COATING (For the detail, refer to M-System's web site.)

- /C01: Silicone coating
- /C02: Polyurethane coating
- /C03: Rubber coating (UL not available)

TERMINAL SCREW MATERIAL

- /S01: Stainless steel (UL not available)

GENERAL SPECIFICATIONS

Construction: Plug-in
Connection: M3 screw terminals (torque 0.8 N·m)
Screw terminal: Chromated steel (standard) or stainless steel
Housing material: Flame-resistant resin (black)
Isolation: Input to output to power
Input waveform
Average sensing: Sine wave
Ovrange output: 0 to 120 % at 1 - 5 V
Zero adjustment: -5 to +5 % (front)
Span adjustment: 95 to 105 % (front)

INPUT SPECIFICATIONS

Frequency: 50 or 60 Hz
Input burden:
≤ 0.1 VA (input 0 - 1 A)
≤ 0.5 VA (input 0 - 5 A)
Overload capacity: 500 % of rating for 5 sec., 120 % continuous
Operational range: 0 - 120 % of rating

OUTPUT SPECIFICATIONS

■ **DC Current:** 0 - 20 mA DC
Minimum span: 1 mA
Offset: Max. 1.5 times span
Load resistance: Output drive 15 V max.
■ **DC Voltage:** 0 - 12 V DC
Minimum span: 5 mV
Offset: Max. 1.5 times span
Load resistance: Output drive 1 mA max.; at ≥ 0.5 V

INSTALLATION

Power Consumption
•AC:
Approx. 3 VA at 100 V
Approx. 4 VA at 200 V
Approx. 5 VA at 264 V
•DC: Approx. 3 W
Operating temperature: -5 to +55°C (23 to 131°F)
Operating humidity: 30 to 90 %RH (non-condensing)
Mounting: Surface or DIN rail
Weight: 150 g (0.33 lb)

PERFORMANCE in percentage of span

Accuracy: ±0.3 %
Temp. coefficient: ±0.015 %/°C (±0.008 %/°F)
Response time: ≤ 0.5 sec. (0 - 90 %)
Ripple: 0.5 %p-p max. (100/120 Hz)
Line voltage effect: ±0.1 % over voltage range

Insulation resistance: ≥ 100 MΩ with 500 V DC
Dielectric strength: 2000 V AC @1 minute (input to output to power to ground)

STANDARDS & APPROVALS

EU conformity:
EMC Directive
EMI EN 61000-6-4
EMS EN 61000-6-2
Low Voltage Directive
EN 61010-1
Installation Category II
Pollution Degree 2
Input or output to power: Reinforced insulation (300 V)
Input to output: Basic insulation (300 V)
RoHS Directive
EN 50581
Approval:
UL/C-UL nonincendive Class I, Division 2,
Groups A, B, C, and D
(ANSI/ISA-12.12.01, CAN/CSA-C22.2 No.213)
UL/C-UL general safety requirements
(UL 61010-1, CAN/CSA-C22.2 No.61010-1)

EXTERNAL DIMENSIONS & TERMINAL ASSIGNMENTS unit: mm (inch)

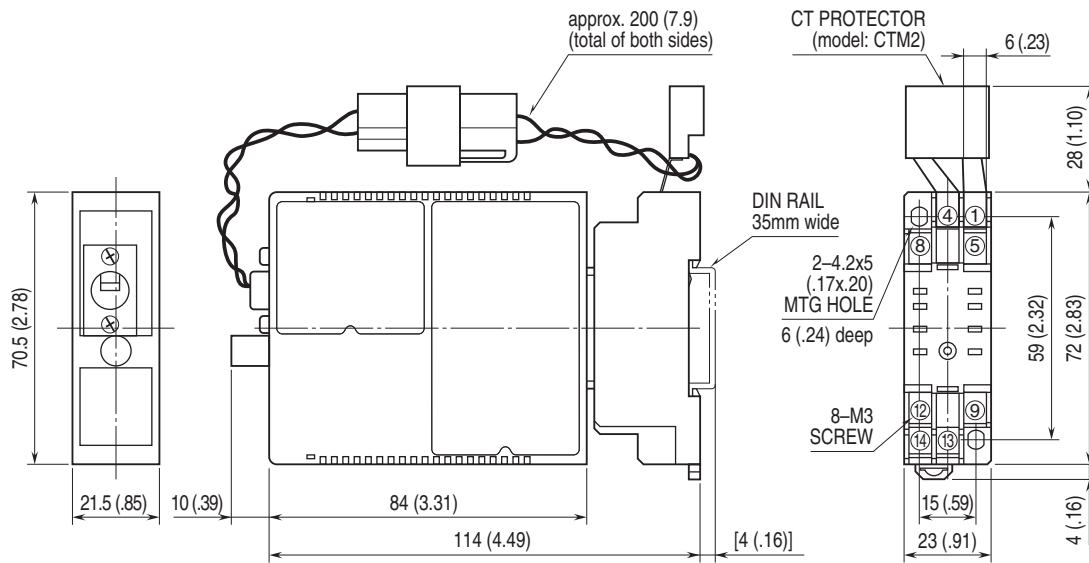

• When mounting, no extra space is needed between units.

SCHEMATIC CIRCUITRY & CONNECTION DIAGRAM

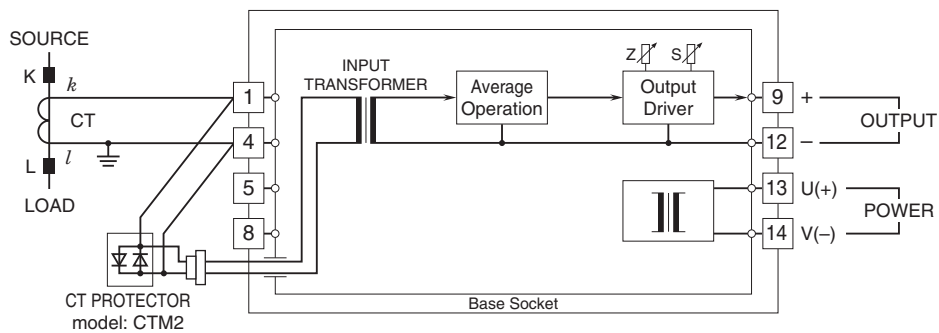

Specifications are subject to change without notice.