



Humidity transmitter

Two-wire technology



Humidity and humidity combined with temperature

Freely selectable span

MIN- / MAX- value memory

Wall or duct mounting

Conformity $\pm 1\%$ rH / $\pm 0,4\%$

PROFILE

Humidity is presented in various methods, as relative value in % rH, (ratio of moisture distributed in the air to the maximum of moisture in air), or absolute as g H₂O / Nm³ dry air¹⁾.

Humidity transmitters are especially designed for monitoring of relative humidity in air conditioning systems as also within industrial processes.

The used two-wire technology features easy installation because supply and signal are united and running via the same pair of wires. Combined humidity and temperature measurement with a second sensing element (-Pt1000-) provide not only for storage and air conditioning special features by simplified mounting and wiring.

Local digital display features easy reading as also scaling of span. An internal lock prevents unauthorized access.

DESCRIPTION

Relative humidity is detected by means of a Polymer capacitor, whose capacity changes with effect to the moisture in the surrounding air. The capacitive change is calibrated in relative humidity and transformed into the 4...20 mA signal.

This capacitor is, like the Pt1000 in the combi-version, mounted inside a supporting tube with protective cage,

which protects against mechanical damage and external impurities.

Digital operation permits adaption onto sensor characteristics (separate for temperature and moisture and is located inside the housing. Electrical connection is performed with an angled standardised connector.

Signals for moisture and temperature are separately available. Fixing holes in the housing for wall mounting are accessible after removing the lid. A special adaptor features mounting the sensor in a duct.

TECHNICAL DATA

INPUT

Humidity, relative
Capacitive thinfilm Polymer-sensor

STANDARD SENSOR

0...100 % rH (inclusive condensation)
Nominal range: 30...80 %

Conformity: $\pm 1\%$ rH

Hysteresis: $\pm 2\%$ rH

Response time: 45 s

Operative range: -40...100 °C

HIGH-HUMIDITY SENSOR

0...100 % rH (inclusive condensation)
Nominal range: 5...95 % rH

Conformity: $\pm 1\%$ rH

Hysteresis: $\pm 2\%$ rH

Response time: 30 s

Operative range: -40...+100 °C

TEMPERATURE

Pt1000 DIN, 1/3 DIN

Range: -40...+120 °C

Conformity: $\pm 0,4\%$

DISPLAY

LCD 4-digits

During operation the relative humidity is displayed [%RH]. For the combi version the display alternates with temperature (hint via arrow).

OUTPUT

Standard current signal: 4...20 mA

Load

$$R_{Load} \frac{U_{Supply} U_{MIN} V}{0,02 A} R_{Lead}$$

Characteristic

Humidity respectively temperature, linear

Conformity: see input +0.2 %

Measuring range

Freely scalable

OPERATION

The output signal can be scaled according to the required measuring range. The Min and Max values can be selected. It also is possible to set the temperature units °C or °F. Setting is locked via internal jumper.

POWER SUPPLY

DC-voltage: 12 ...30 VDC
(separate for humidity and temperature)

Effect of supply: 0.1 % / 10 V

Permissible ripple: 0.5 V_{pp}

Behaviour with mains failure

Loss of function

ENVIRONMENTAL CONDITIONS

Temperature limits

Operation

Sensor, probe: -40...100 °C

Electronics: 0...70 °C

Nominal temperature: 25 °C

Storage: -20...+70 °C

Relative humidity: 0...98 %, condensation

Temperature effect: 0.4 % / 10 K

Long-term effect: at standard atmosphere: 2 % rH / year

ELECTROMAGNETIC COMPATIBILITY

Meets EN 50 081-2 and EN 50 082-2, CE label designated.

GENERAL

Dimensions

in mm	wall sensor	duct sensor
Electronics	82 x 55 x 118	82 x 55 x 118
Sensor	14, l= 50	14, l= 220 ¹⁾

Fig. 1 electrical connections

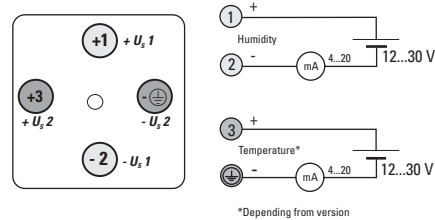

¹⁾ Other length 300, 400 or 500 mm to specification

²⁾ Specify operating range, e.g. 0...40 % rH or 70...100 % rH, if not standard. Also indication of operating level (e.g. 68% rH) should be given.

³⁾ Mounting adaptor (flange) is included in delivery.

⁴⁾ Configured only in factory, dimensions on request.

⁵⁾ Combi= combination of humid.& temp. Separate supply necessary!

Used materials

Housing: ABS

Sensor tube: PVDF 14 x 2 mm

Protective cage: SS wire mesh,

Adaptor: Poliamide reinforced

Mode of protection: IP 65

Electrical connection

Angled connector to DIN 43 650

for cable max. 1.5 mm², 4.5 or 7 mm

Weight

Wall sensor: 0.25 kg

Duct sensor: 0.3 kg

Radiation protector: 0.35 kg

Mounting

Wall sensor: wall

Duct sensor: with adaptor on duct³⁾ or

with extra mounting jig at wall.

Outdoor mounting only with radiation protector⁴⁾.

Mounting position

Sensor vertical up to horizontal.

ORDERING-DATA²⁾

Description	Order-no.
Standard-Sensor	9407-292-000 . 1
Humidity wall	0
Humid./Temp.-wall ⁵⁾	1
Humidity duct	2
Humid./Temp-duct ⁵⁾	3
High Humidity/Temp. Sensor²⁾	
Humidity wall special	4
Humid./Temp-wall special ⁵⁾	5
Humidity duct special	6
Humid./Temp-duct special ⁵⁾	7
length to specification¹⁾	. 2

Optional accessories

Adaptor ³⁾	9407-291-00081
Radiation protector ⁴⁾	9407-291-00091

Accessories

Instructions

9499-040-79011 english

Fig. 2 Dimensions wall mounting

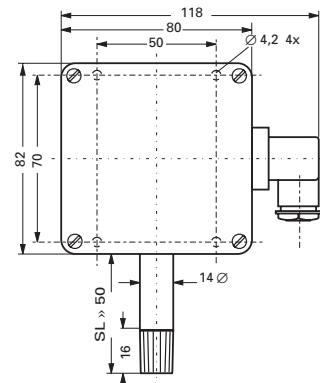
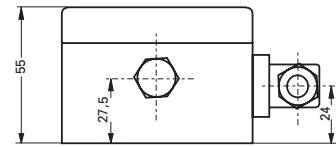

Fig. 3 Dimensions duct mounting

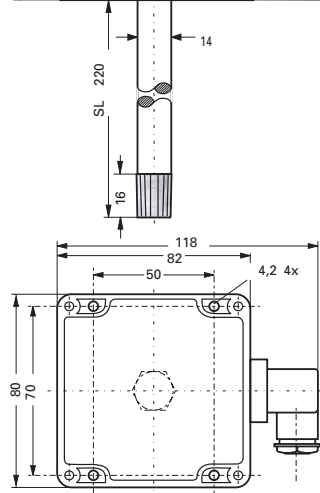
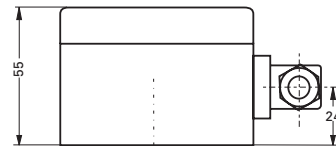
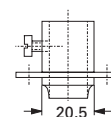
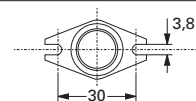

Fig. 4 Dimensions duct adaptor



Deutschland

PMA Prozeß- und Maschinen- Automation GmbH
Miramstrasse 87, D-34123 Kassel

Tel./Fax: (0561) 505 - 1307/-1710
E-mail: mailbox@pma-online.de
Internet: http://www.pma-online.de

Your local distributor