

Digital Panel Meters 47 Series

DC INPUT DIGITAL PANEL METER

(4 ½ digit, LED display type)

Functions & Features

- 4 ½ digit DC input digital panel meter
- 1/8 DIN size
- Moving average function to suppress the display flickering
- Scaling, forced zero, low-end cutout
- Max. and Min. value display
- Safety terminal cover tethered to the device with a strap
- IP66 front panel
- Separable terminal block

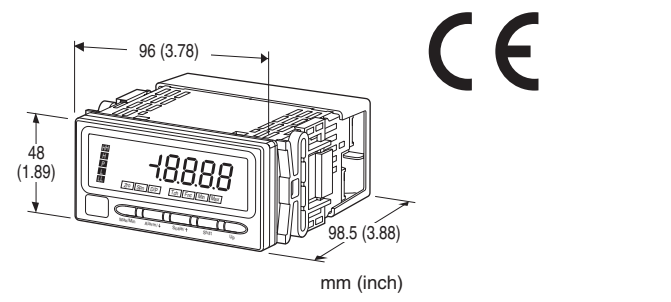

MODEL: 47LV-[1][2][3][4]-[5][6]

ORDERING INFORMATION

- Code number: 47LV-1[1][2][3][4]-[5][6]
- Specify a code from below for each [1] through [6].
(e.g. 47LV-101G-M2/Q)
- Specify the specification for option code /Q
(e.g. /C01/S01/SET)

[1] INPUT

- 1: ±10 V, ±5 V, 0 - 5 V, 1 - 5 V
0 - 20 mA, 4 - 20 mA
- 2: ±1 V, ±100 mV, ±10 mV, ±1 mA
- 3: ±200 V, ±100 mA
- 4: ±100 µA (CE not available)
- 5: ±2 A, ±1 A (CE not available)
- 6: ±700 V (CE not available)

[2] DC OUTPUT

0: Without

Current

- A: 4 - 20 mA DC (Load resistance 550 Ω max.)
- D: 0 - 20 mA DC (Load resistance 550 Ω max.)

Voltage

- 3: 0 - 1 V DC (Load resistance 1000 Ω min.)
(CE not available)

- 4: 0 - 10 V DC (Load resistance 10 kΩ min.)
- 5: 0 - 5 V DC (Load resistance 5000 Ω min.)
- 6: 1 - 5 V DC (Load resistance 5000 Ω min.)
- 4W: -10 - +10 V DC (Load resistance 10 kΩ min.)

[3] ALARM OUTPUT

- 0: None
- 1: N.O. relay contact, 4 points
- 2: SPDT relay contact, 2 points

[4] DISPLAY COLOR

- R: Red
- YR: Orange
- G: Green
- BG: Bluegreen
- B: Blue
- W: White

[5] POWER INPUT

AC Power

M2: 100 - 240 V AC (Operational voltage range 85 - 264 V, 50/60 Hz)

DC Power

- R: 24 V DC
(Operational voltage range 24 V ±10 %, ripple 10 %p-p max.)
- P: 110 V DC
(Operational voltage range 85 - 150 V, ripple 10 %p-p max.)

[6] OPTIONS

- blank: none
- /Q: With options (specify the specification)

SPECIFICATIONS OF OPTION: Q (multiple selections)

COATING (For the detail, refer to M-System's web site.)

Moving parts and indicators are not coated.

- /C01: Silicone coating
- /C02: Polyurethane coating
- /C03: Rubber coating

TERMINAL SCREW MATERIAL

/S01: Stainless steel

EX-FACTORY SETTING

/SET: Preset according to the Ordering Information Sheet
(No. ESU-9502)

GENERAL SPECIFICATIONS

Construction: Panel flush mounting

Degree of protection: IP66; applicable to the front of the panel meter mounted according to the specified panel cutout

Connection: M3 screw terminals (torque 0.6 N·m)

Screw terminal: Nickel-plated steel (standard) or stainless

steel

Housing material: Flame-resistant resin (gray)

Isolation: Input to DC output to HH output or H output to L output or LL output to power

Setting: (Front button)

- Scaled range
- Input type
- Alarm setpoint
- Hysteresis (deadband)
- Moving average
- Others

(Refer to the instruction manual for details)

Read rate: 40 times/sec. (25 msec.)

Averaging: None or moving average

Lockout Setting: Prohibiting certain operations; protecting settings

DISPLAY

Display: 16 mm (.63) high, 4 ½ digits, LED

Display range: -19999 to 19999

Decimal point position: 10⁻¹, 10⁻², 10⁻³, 10⁻⁴ or none

Zero indication: Higher-digit zeros are suppressed.

Over-range indication: '19999' or '19999' blinking for display values out of the scaled range.

'S.ERR' and 'Min' or 'Max' blinking when the input signal is out of the usable range.

Alarm status indication

LL indicator: Turns on when the LL alarm is tripped.

L indicator: Turns on when the L alarm is tripped.

H indicator: Turns on when the H alarm is tripped.

HH indicator: Turns on when the HH alarm is tripped.

P indicator: Turns on when none of the other alarms is tripped.

Only 'P' turns on with no-alarm-output type. 'LL' or 'HH' does not turn on with dual-alarm-output type.

All setpoints can be independently set either for Hi or Lo alarm trip.

Engineering unit indication: Sticker label attached

DC, AC, mV, V, kV, μA, mA, A, kA, mW, W, kW, var, kvar, Mvar, VA, Hz, Ω, kΩ, MΩ, cm, mm, m, m/sec, mm/min, cm/min, m/min, m/h, m/s², inch, l, l/s, l/min, l/h, m³, m³/sec, m³/min, m³/h, Nm³/h, N·m, N/m², g, kg, kg/h, N, kN, Pa, kPa, MPa, t, t/h, °C, °F, %RH, J, kJ, MJ, rpm, sec, min, pH, %, ppm, etc.

INPUT SPECIFICATIONS

Default setting

Input code 1: Measuring range ±10 V

Input code 2: Measuring range ±1 V

Input code 3: Measuring range ±200 V

Input code 4: Measuring range ±100 μA

Input code 5: Measuring range ±2 A

Input code 6: Measuring range ±700 V

Overload capacity

Input code 5: ±3 A for 10 sec., ±2.4 A continuous

Input code 6: ±1000 V for 10 sec., ±840 V continuous

DC INPUT

TYPE IND	MEASURING RANGE	OPERATIONAL RANGE	INPUT IMPEDANCE
V10	±10V	-11 – +11V	1MΩ minimum
V5	±5V	-5.5 – +5.5V	1MΩ minimum
V0-5	0 – 5V	-0.3 – +5.3V	1MΩ minimum
V1-5	1 – 5V	0.7 – 5.3V	1MΩ minimum
A0-2	0 – 20mA	-2 – +22mA	approx. 10Ω
A4-2	4 – 20mA	2 – 22mA	approx. 10Ω
V1	±1V	-1.1 – +1.1V	1MΩ minimum
V01	±100mV	-110 – +110mV	1MΩ minimum
V001	±10mV	-11 – +11mV	1MΩ minimum
A1	±1mA	-1.1 – +1.1mA	approx. 100Ω
V200	±200V	-220 – +220V	1MΩ minimum
A100	±100mA	-110 – +110mA	approx. 10Ω
A01	±100μA	-110 – +110μA	approx. 1kΩ
A2-2	±2A	-2.2 – +2.2A	approx. 0.1Ω
A1-1	±1A	-1.1 – +1.1A	approx. 0.1Ω
V700	±700V	-770 – +770V	1MΩ minimum

OUTPUT SPECIFICATIONS

DC Current

Operational range: -5 – +105 %

DC Voltage

Operational range: -5 – +105 %

Alarm Output: Relay contact

Rated load: 250 V AC @ 3 A (cos φ = 1)

30 V DC @ 3 A (resistive load)

Maximum switching voltage: 250 V AC, 30 V DC

Maximum switching power: 750 VA, 90 W (resistive load)

Minimum load: 5 V DC @ 10 mA

Mechanical life: ≥ 5 × 10⁶ cycles (rate 180 cycles/min.)

INSTALLATION

Power consumption

•AC: Approx. 6.5VA

•DC: Approx. 3 W

Operating temperature: -10 to +55°C (14 to 131°F)

Operating humidity: 30 to 90 %RH (non-condensing)

Mounting: Panel flush mounting

Weight: 300 g (0.66 lbs)

PERFORMANCE

Accuracy

Display: $\pm 0.1\% \pm 1$ digit
 $\pm 0.2\% \pm 1$ digit for ± 10 mV range
Output: $\pm 0.1\%$ (DC output = display + output)
Temp. coefficient: $\pm 0.015\%/^{\circ}\text{C}$ ($\pm 0.008\%/^{\circ}\text{F}$)
 $\pm 0.03\%/^{\circ}\text{C}$ ($\pm 0.02\%/^{\circ}\text{F}$) for ± 10 mV range
Input resolution: Max. 16 bits
Output resolution: Max. 14 bits
Response time: ≤ 0.5 sec.
(alarm output: 0 - 100 % at 90 % setpoint)
 ≤ 0.5 sec. (DC output: 0 - 90 %)
Line voltage effect: $\pm 0.1\%$ over voltage range
Insulation resistance: $\geq 100\ \text{M}\Omega$ with 500 V DC
Dielectric strength: 2000 V AC @ 1 minute (input to DC output to HH output or H output to L output or LL output to power to ground)

STANDARDS & APPROVALS

CE conformity:
EMC Directive (2004/108/EC)
EMI EN 61000-6-4: 2007
EMS EN 61000-6-2: 2005
Low Voltage Directive (2006/95/EC)
EN 61010-1: 2001
Measurement Category II (alarm)
Installation Category II (power)
Pollution degree 2
Input or DC output to alarm output to power: Reinforced insulation (300 V)
Input to DC output: Basic insulation (300 V)
Protection against access to the terminal blocks:
Finger protection (VDE 0660-514)

EXTERNAL VIEW

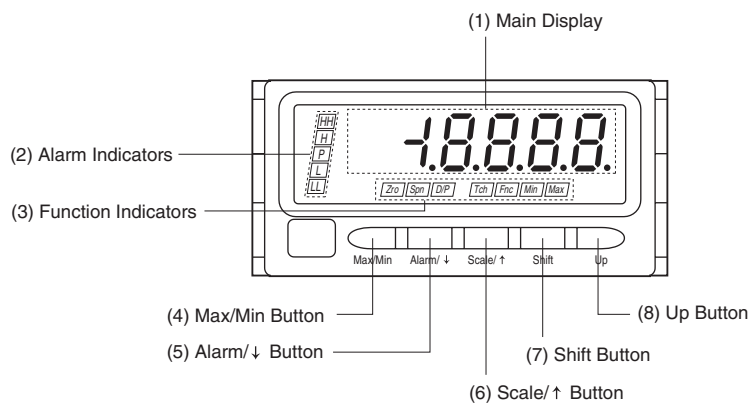

• COMPONENT IDENTIFICATION

No.	COMPONENT	FUNCTION
(1)	Main display	Indicates present values and setting values.
(2)	Alarm indicators	Indicate alarm status of the input signal.
(3)	Function indicators	Indicate the status in each setting mode.
(4)	Max/Min button	Used to switch the main display to show the present values, maximum values or minimum values.
(5)	Alarm/↓ button	Used to confirm alarm setpoints, to move on to the alarm and other setting modes; or to shift setting mode.
(6)	Scale/↑ button	Used to move on to the scaling and other setting modes; or to shift through setting items in each through setting items in each setting mode.
(7)	Shift button	Used to move on to the setting standby status and shift through display digits in each setting item.
(8)	Up button	Used to change setting values, to execute/cancel Forced Zero or to select setting values.

Refer to the instruction manual for details.

EXTERNAL DIMENSIONS & TERMINAL ASSIGNMENTS unit: mm (inch)

■ TOP VIEW

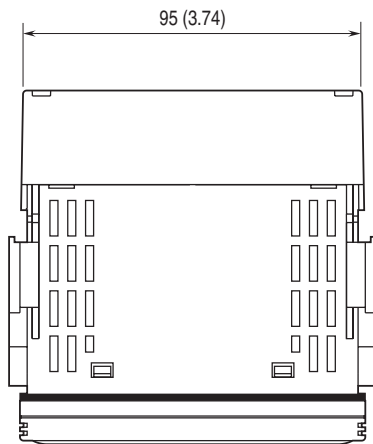

■ FRONT VIEW

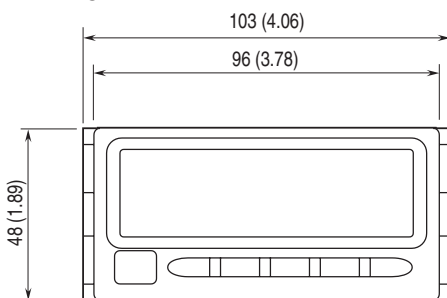

■ SIDE VIEW

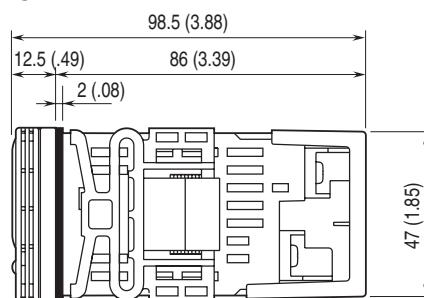

■ REAR VIEW

• No Alarm Output

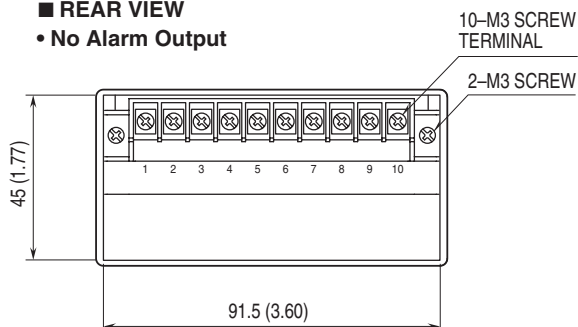

• Alarm Output

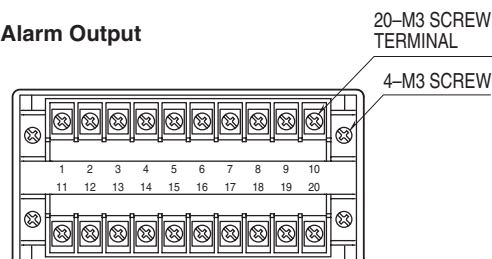

MOUNTING REQUIREMENTS unit: mm

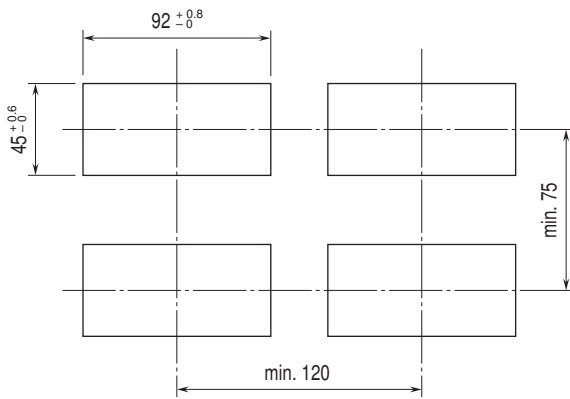

Panel thickness: 1.6 to 8.0 mm

SCHEMATIC CIRCUITRY & CONNECTION DIAGRAM

■ ALARM SUFFIX CODE 0: No alarm output

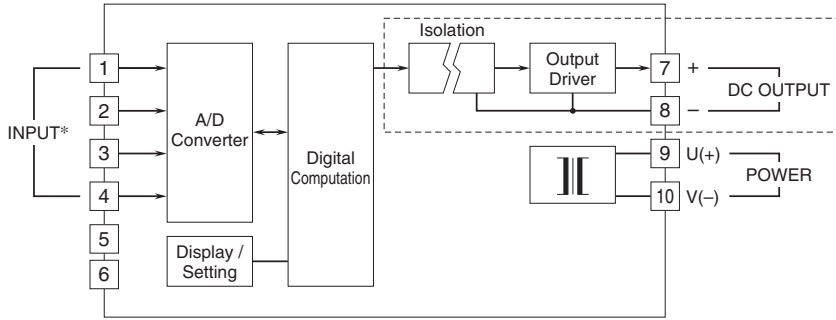

■ ALARM SUFFIX CODE 1: N.O. contact, 4 points

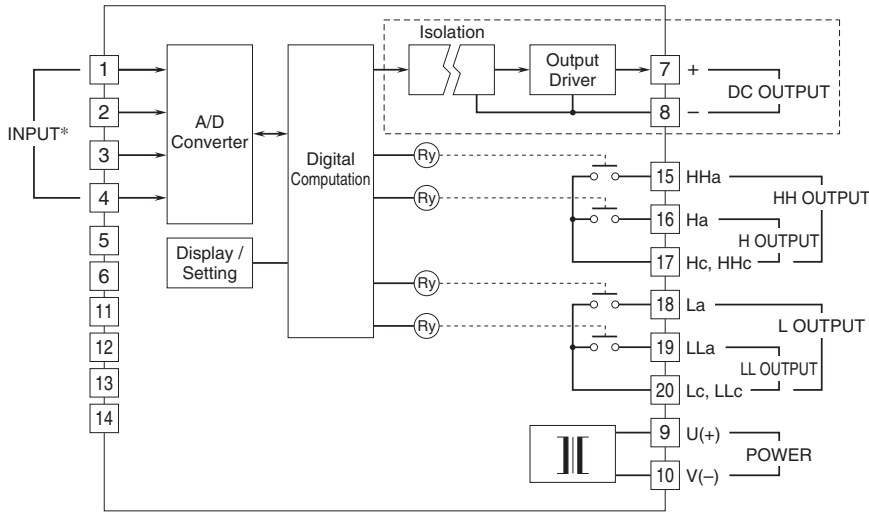

■ ALARM SUFFIX CODE 2: SPDT contact, 2 points

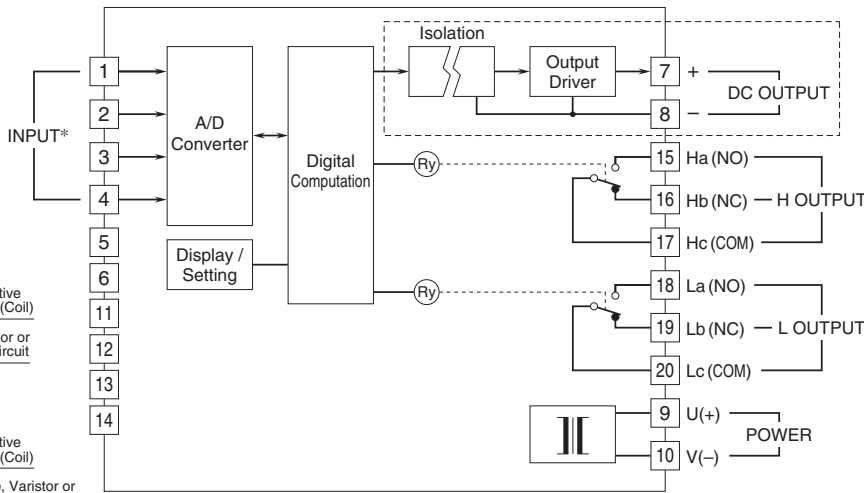

■ Relay Protection

• AC Powered



• DC Powered

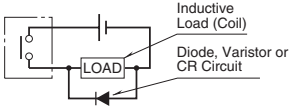

Note: The section enclosed by broken line is only with DC output option.

* Input shunt resistor incorporated for current input.

• Input code: 1, 2

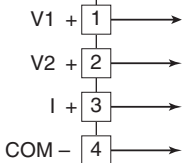

• Input code: 3

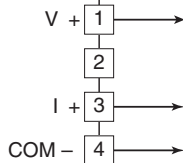

• Input code: 4

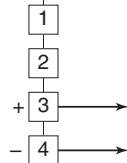

• Input code: 5, 6

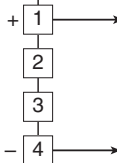

• Input Terminal Assignments

INPUT TYPE (indicator)	MEASURING RANGE	INPUT TERMINALS	INPUT TYPE (indicator)	MEASURING RANGE	INPUT TERMINALS
V200 V10 V5 V1 A2-2 A1-1 V700	±200V ±10V ±5V ±1V ±2A ±1A ±700V	[1]-[4]	V0-5 V1-5 A100 A1 A0-2 A4-2 A01	0 - 5V 1 - 5V ±100mA ±1mA 0 - 20mA 4 - 20mA ±100μA	[2]-[4] [3]-[4]
V01 V001	±100mV ±10mV	[2]-[4]			



Specifications are subject to change without notice.