

Digital Panel Meters 47 Series

RTD INPUT DIGITAL PANEL METER

(4 digit, LED display type)

Functions & Features

- 4-digit RTD input digital panel meter
- 1/8 DIN size
- Moving average function to suppress the display flickering
- Max. and Min. value display
- IP66 front panel
- Separable terminal block
- Rear terminal cover for safety strapped to the meter

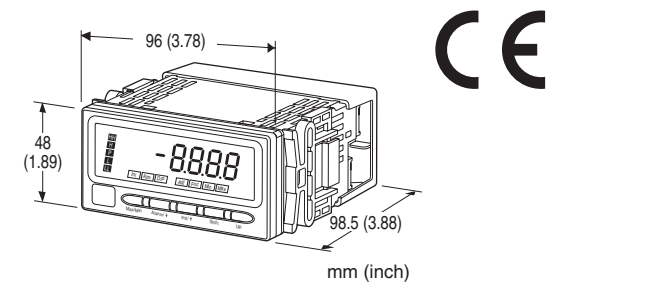

MODEL: 47LR-1[1][2][3]-[4][5]

ORDERING INFORMATION

- Code number: 47LR-1[1][2][3]-[4][5]
- Specify a code from below for each [1] through [5]. (e.g. 47LR-101G-M2/Q)
- Specify the specification for option code /Q (e.g. /C01/S01/SET)

INPUT - Field-selectable

- 1: JPt 100 (JIS '89)
- Pt 100 (JIS '89)
- Pt 100 (JIS '97, IEC)
- Pt 50Ω (JIS '81)

[1] DC OUTPUT

0: Without

Current

- A: 4 - 20 mA DC (Load resistance 550 Ω max.)
- D: 0 - 20 mA DC (Load resistance 550 Ω max.)

Voltage

- 4: 0 - 10 V DC (Load resistance 10 kΩ min.)
- 5: 0 - 5 V DC (Load resistance 5000 Ω min.)
- 6: 1 - 5 V DC (Load resistance 5000 Ω min.)
- 4W: -10 - +10 V DC (Load resistance 10 kΩ min.)

[2] ALARM OUTPUT

- 0: None
- 1: N.O. relay contact, 4 points
- 2: SPDT relay contact, 2 points

[3] DISPLAY COLOR

- R: Red
- YR: Orange
- G: Green
- BG: Bluegreen
- B: Blue
- W: White

[4] POWER INPUT

AC Power

M2: 100 - 240 V AC (Operational voltage range 85 - 264 V, 50/60 Hz)

DC Power

- R: 24 V DC (Operational voltage range 24 V ±10 %, ripple 10 %p-p max.)
- P: 110 V DC (Operational voltage range 85 - 150 V, ripple 10 %p-p max.)

[5] OPTIONS

- blank: none
- /Q: With options (specify the specification)

SPECIFICATIONS OF OPTION: Q (multiple selections)

COATING (For the detail, refer to M-System's web site.)

Moving parts and indicators are not coated.

- /C01: Silicone coating
- /C02: Polyurethane coating
- /C03: Rubber coating

TERMINAL SCREW MATERIAL

/S01: Stainless steel

EX-FACTORY SETTING

/SET: Preset according to the Ordering Information Sheet (No. ESU-9503)

GENERAL SPECIFICATIONS

- Construction:** Panel flush mounting
- Degree of protection:** IP66; applicable to the front of the panel meter mounted according to the specified panel cutout
- Connection:** M3 screw terminals (torque 0.6 N·m)
- Screw terminal:** Nickel-plated steel (standard) or stainless steel
- Housing material:** Flame-resistant resin (gray)
- Isolation:** Input to DC output to HH output or H output to L output or LL output to power
- Burnout:** Upscale standard; downscale optional by

programming

Setting: (Front button)

- Input type
- Alarm setpoint
- Hysteresis (deadband)
- Moving average
- Others

(Refer to the instruction manual for details)

Read rate: Max. 20 times/sec. (50 msec.)

Averaging: None or moving average

Lockout Setting: Prohibiting certain operations; protecting settings

DISPLAY

Display: 16 mm (.63) high, 4 digits LED

Display range: -1999 to 9999

Minimum display/setting scale: 0.1°C or 1°F

Decimal point position: 10⁻¹ or none

Zero indication: Higher-digit zeros are suppressed.

Over-range indication: 'S.ERR' blinking when the input signal is out of the usable range.

Burnout indication: 'B.ERR' blinking

Alarm status indication

LL indicator: Turns on when the LL alarm is tripped.

L indicator: Turns on when the L alarm is tripped.

H indicator: Turns on when the H alarm is tripped.

HH indicator: Turns on when the HH alarm is tripped.

P indicator: Turns on when none of the other alarms is tripped.

Note: Only 'P' turns on with no-alarm-output type. 'LL' or 'HH' does not turn on with dual-alarm-output type.

All setpoints can be independently set either for Hi or Lo alarm trip.

Engineering unit indication: Sticker label attached

DC, AC, mV, V, kV, μA, mA, A, kA, mW, W, kW, var, kvar, Mvar, VA, Hz, Ω, kΩ, MΩ, cm, mm, m, m/sec, mm/min, cm/min, m/min, m/h, m/s², inch, l, l/s, l/min, l/h, m³, m³/sec, m³/min, m³/h, Nm³/h, N·m, N/m², g, kg, kg/h, N, kN, Pa, kPa, MPa, t, t/h, °C, °F, %RH, J, kJ, MJ, rpm, sec, min, pH, %, ppm, etc.

INPUT SPECIFICATIONS

■ RTD: 3-wire RTDs

Maximum leadwire resistance: 10 Ω per wire

Sensing current: 1 mA

Default input type: Pt 100 (JIS '97, IEC)

Temperature Range

RTD		CONFORMANCE RANGE	USABLE RANGE
JPt 100 (JIS '89)	°C	-200*1 to +500	-230*1 to +530
	°F	-328 to +932	-382 to +986
Pt 100 (JIS '89)	°C	-200*1 to +650	-230*1 to +680
	°F	-328 to +1202	-382 to +1256
Pt 100 (JIS '97, IEC)	°C	-200*1 to +850	-230*1 to +880
	°F	-328 to +1562	-382 to +1616
Pt 50Ω (JIS '81)	°C	-200*1 to +649	-230*1 to +679
	°F	-328 to +1202	-382 to +1256

*1. -199.9 with '1 decimal place' setting

OUTPUT SPECIFICATIONS

■ DC Current

Operational range: -5 - +105 %

■ DC Voltage

Operational range: -5 - +105 %

■ Alarm Output: Relay contact

Rated load: 250 V AC @ 3 A (cos φ = 1)

30 V DC @ 3 A (resistive load)

Maximum switching voltage: 250 V AC, 30 V DC

Maximum switching power: 750 VA, 90 W (resistive load)

Minimum load: 5 V DC @ 10 mA

Mechanical life: ≥ 5 × 10⁶ cycles (rate 180 cycles/min.)

INSTALLATION

Power consumption

•AC: Approx. 6.5VA

•DC: Approx. 3 W

Operating temperature: -10 to +55°C (14 to 131°F)

Operating humidity: 30 to 90 %RH (non-condensing)

Mounting: Panel flush mounting

Weight: 300 g (0.66 lb)

PERFORMANCE

Accuracy

Display: ±1°C ±1 digit (±2°F ±1 digit)

Minimum display scale 0.1°C or 1°F

Output: ±0.15 % (DC output = display + output)

Temp. coefficient: ±0.03 %/°C (±0.02 %/°F) when the input range is set to the maximum span.

Input resolution: Max. 16 bits

Output resolution: Max. 13 bits

Response time: ≤ 0.5 sec.

(alarm output: 0 - 100 % at 90 % setpoint)

≤ 0.7 sec. (DC output: 0 - 90 %)

Burnout response: ≤ 10 sec.

Line voltage effect: ±0.1 % over voltage range

Insulation resistance: ≥ 100 MΩ with 500 V DC

Dielectric strength: 2000 V AC @ 1 minute (input to DC)

output to HH output or H output to L output or LL output to power to ground)

STANDARDS & APPROVALS

CE conformity:

EMC Directive (2004/108/EC)

EMI EN 61000-6-4: 2007

EMS EN 61000-6-2: 2005

Low Voltage Directive (2006/95/EC)

EN 61010-1: 2001

Measurement Category II (alarm)

Installation Category II (power)

Pollution degree 2

Input to alarm output to power: Reinforced insulation (300 V)

Input to DC output: Basic insulation (300 V)

Protection against access to the terminal blocks:

Finger protection (VDE 0660-514)

EXTERNAL VIEW

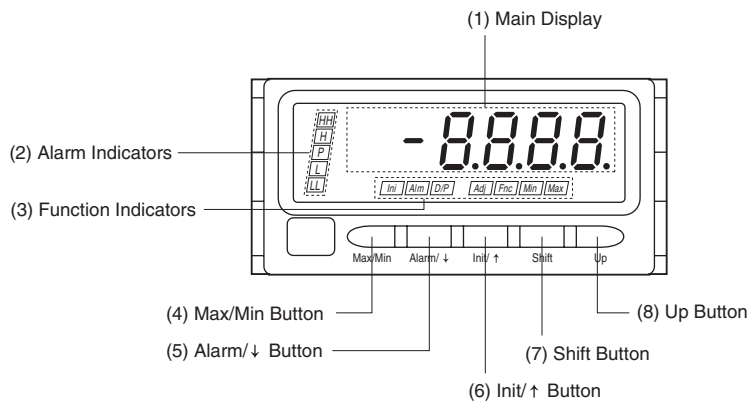

• COMPONENT IDENTIFICATION

No.	COMPONENT	FUNCTION
(1)	Main display	Indicates present values, setting values.
(2)	Alarm indicators	Indicate alarm status of the input signal.
(3)	Function indicators	Indicate setting modes and status.
(4)	Max/Min button	Used to switch the main display to show present values, maximum values or minimum values.
(5)	Alarm/↓ button	Used to move on to the alarm setting mode; or to shift through setting items in each setting mode.
(6)	Init/↑ button	Used to move on to the initial setting mode; or to shift through setting items in each setting mode.
(7)	Shift button	Used to move on to the setting standby status and shift through display digits in each setting item.
(8)	Up button	Used to change setting values.

Refer to the instruction manual for details on each function.

EXTERNAL DIMENSIONS & TERMINAL ASSIGNMENTS unit: mm (inch)

■ TOP VIEW

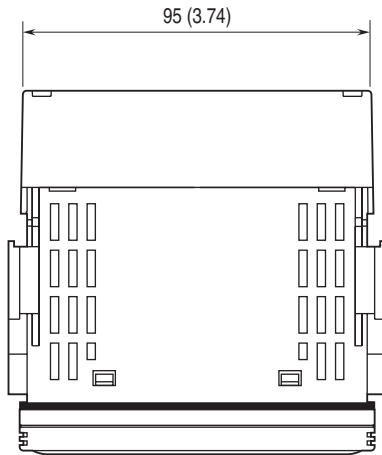

■ FRONT VIEW

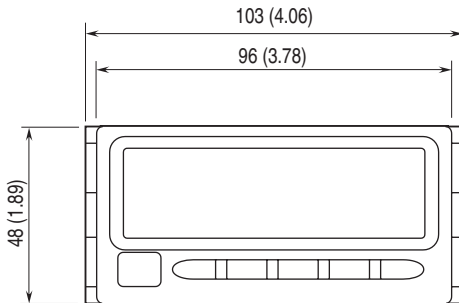

■ SIDE VIEW

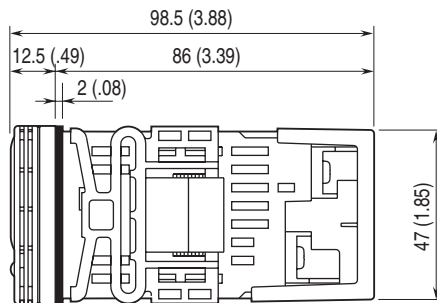

■ REAR VIEW

• No Alarm Output

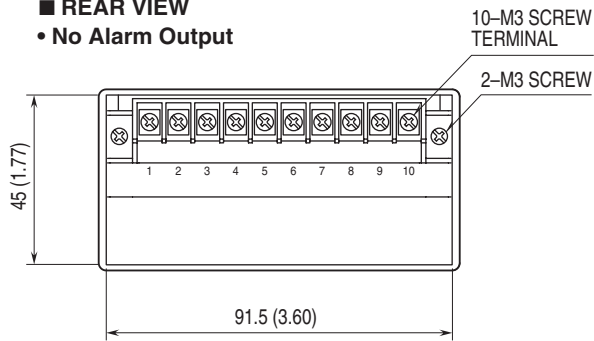

• Alarm Output

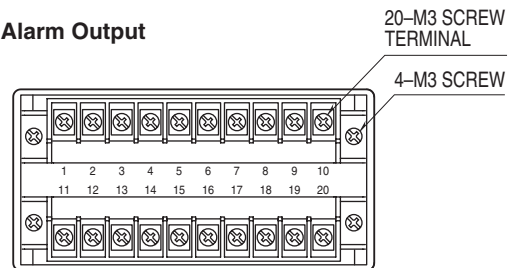

MOUNTING REQUIREMENTS unit: mm

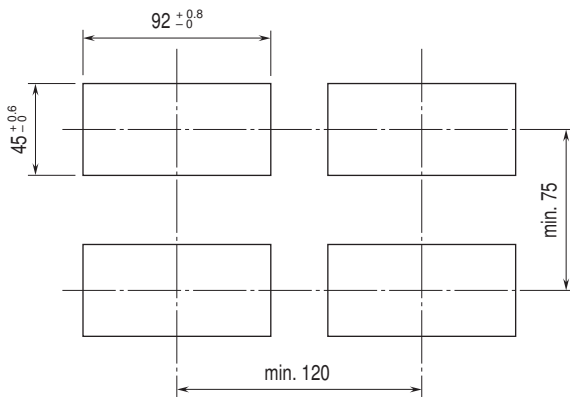

Panel thickness: 1.6 to 8.0 mm

SCHEMATIC CIRCUITRY & CONNECTION DIAGRAM

■ **ALARM SUFFIX CODE 0: No alarm output**

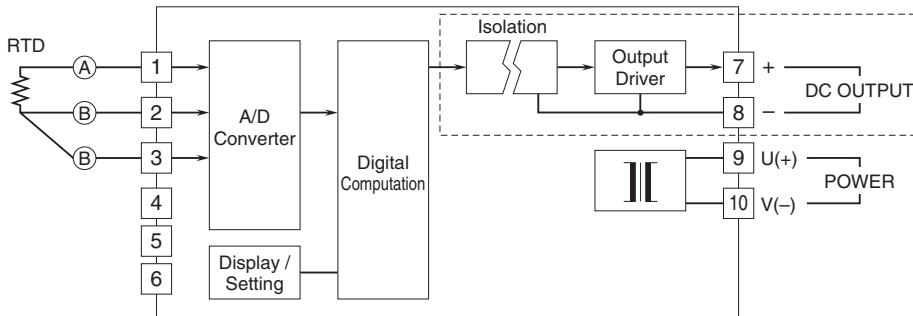

■ **ALARM SUFFIX CODE 1: N.O. contact, 4 points**

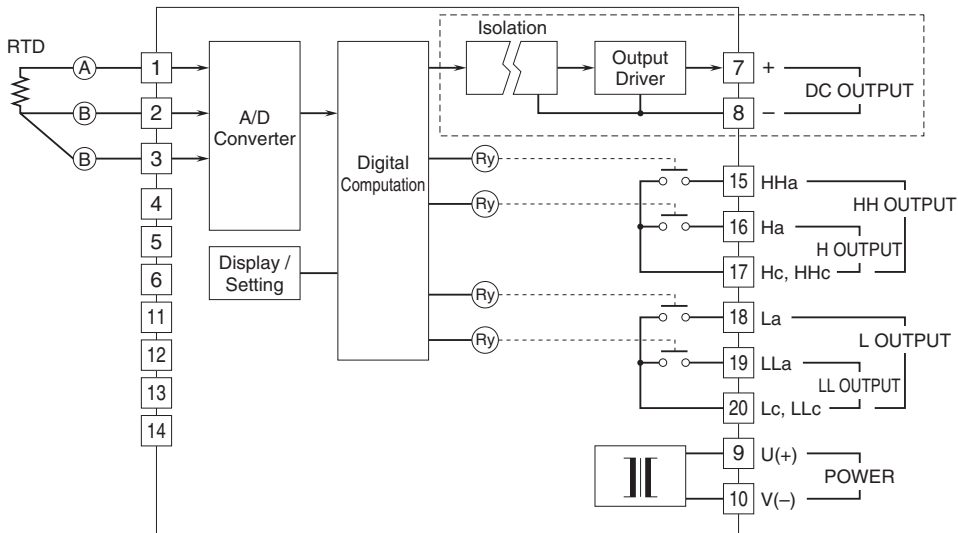

■ **ALARM SUFFIX CODE 2: SPDT contact, 2 points**

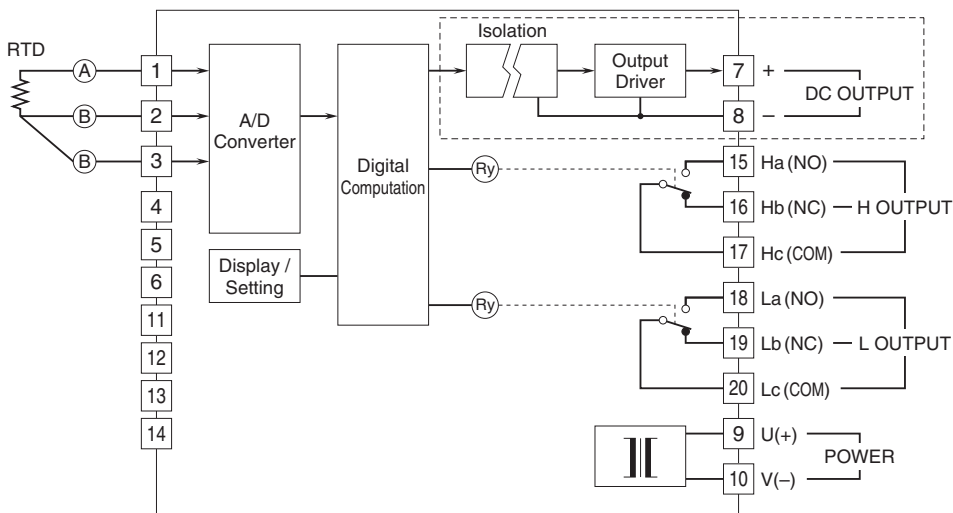

Note: The section enclosed by broken line is only with DC output option.

■ **Relay Protection**

• AC Powered

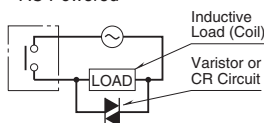

• DC Powered

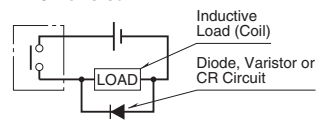



Specifications are subject to change without notice.