

Digital Panel Meters 47 Series

DC INPUT DIGITAL PANEL METER

(5½ digit, LCD display type)

Functions & Features

- 5 1/2 digit DC input digital panel meter
- Scaling range -20000 to 100000
- 1/8 DIN size
- Display color can be changed at alarm
- Bargraph indicator shows approximate measuring status
- 12 V or 24 V excitation supply
- External event trigger input
- RS-485 / Modbus RTU output
- Infrared interface
- BCD output
- Loop test output (DC output option)
- IP66 front panel
- Separable terminal block
- Safety terminal cover tethered to the device with a strap

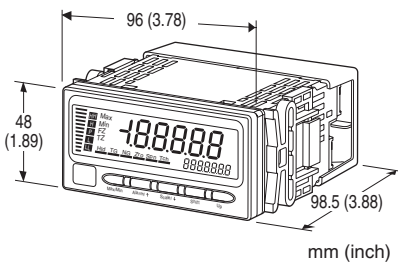

MODEL: 47DV-[1][2][3][4]-[5][6]

ORDERING INFORMATION

- Code number: 47DV-[1][2][3][4]-[5][6]
Specify a code from below for each [1] through [6].
(e.g. 47DV-1111-M2/Q)
- Specify the specification for option code /Q
(e.g. /C01/S01/SET)

[1] INPUT

- 1: DC voltage
- 2: DC current

[2] DC OUTPUT

- 0: Without
- 1: With

[3] EXCITATION SUPPLY

- 1: +12 V sensor excitation
- 2: +24 V two-wire transmitter excitation

[4] I/O OPTIONS

- 0: None
- 1: Alarm output: N.O. relay, 4 points
- 2: Alarm output: SPDT relay, 2 points
- 3: Alarm output: N.O. photo MOS relay, 4 points
- 4: Network interface: RS-485 / Modbus RTU
- 5: BCD output
- 6: Event trigger input
- 7: Alarm output: N.O. relay, 4 points
+ Network interface: RS-485 / Modbus RTU
- 8: Alarm output: SPDT relay, 2 points +
Network interface: RS-485 / Modbus RTU
- 9: Alarm output: N.O. photo MOS relay, 4 points + BCD output
- A: Event trigger input + BCD output

[5] POWER INPUT

AC Power

M2: 100 - 240 V AC (Operational voltage range 85 - 264 V, 50/60 Hz)

DC Power

R: 24 V DC

(Operational voltage range 24 V ±10 %, ripple 10 %p-p max.)

P: 110 V DC

(Operational voltage range 85 - 150 V, ripple 10 %p-p max.)

[6] OPTIONS

- blank: none
- /Q: With options (specify the specification)

SPECIFICATIONS OF OPTION: Q (multiple selections)

COATING (For the detail, refer to M-System's web site.)

Moving parts and indicators are not coated.

- /C01: Silicone coating
- /C02: Polyurethane coating
- /C03: Rubber coating

TERMINAL SCREW MATERIAL

/S01: Stainless steel

EX-FACTORY SETTING

/SET: Preset according to the Ordering Information Sheet
(No. ESU-9501)

RELATED PRODUCTS

- Resistor module (model: REM2-250)
 - Connector terminal block (model: CNT)
 - Special cable (model: HDR40)
 - Infrared Communication Adaptor (model: COP-IRU)
 - PC configurator software (model: 47DCFG)
- Downloadable at M-System's web site.

GENERAL SPECIFICATIONS

Construction: Panel flush mounting

Degree of protection: IP66; applicable to the front of the panel meter mounted according to the specified panel cutout

Connection

Input, excitation supply, DC output, relay output, network interface, power: M3 screw terminals (torque 0.6 N·m)

Photo MOS relay, event trigger input: Euro Type Connector Terminal (applicable wire size: max. 1.3 dia., 0.5 - 1.25 mm²)

BCD output: 50-pin connector (Honda Tsushin Kogyo HDR-EC50LFDT1-SLE+)

Screw terminal: Nickel-plated steel (standard) or stainless steel

Isolation: Input or excitation supply to DC output to HH output or H output to L output or LL output to network or BCD output or event trigger input to power

Housing material: Flame-resistant resin (gray)

Infrared communication: Transmission distance max. 1 meter (for use with the COP-IRU)

Setting: (Front button)

- Scaled range
- Input type
- Alarm setpoint
- Hysteresis (deadband)
- Averaging
- Others

(Refer to the instruction manual for details)

Sampling rate: 20 times/sec. (50 msec.)

Averaging: Simple average, moving average or no averaging

Lockout Setting: Prohibiting certain operations; protecting settings

DISPLAY

Main display: 5½ digits, LCD with LED backlight, 7-segment, 14.2 mm (.56) high

Color: Red or green changeable at alarm

Scaling range: -20000 to 100000

Decimal point position: 10⁻¹, 10⁻², 10⁻³, 10⁻⁴ or none

Zero indication: Higher-digit zeros are suppressed.

Sub display: 7 digits, LCD with LED backlight, 5.5 mm (.22) high,

Color: Green

Over-range indication: ' -20000 ' or ' 100000 ' blinking for display values out of the scaled range (decimal point position depending upon setting). 'S.ERR' (main display) and 'UNDER' or 'OVER' (sub display) blinking when the input signal is out of the usable range.

Bargraph

No. of LED segments: 20, displayed with divided by 10

Color: Amber

Alarm status indication

All setpoints can be set and indicated regardless of alarm output options. Each is independently set either for Hi or Lo alarm trip.

LL indicator: Turns on in red when the LL alarm is tripped.

L indicator: Turns on in red when the L alarm is tripped.

H indicator: Turns on in green when the H alarm is tripped.

HH indicator: Turns on in green when the HH alarm is tripped.

P indicator: Turns on in amber when none of the other alarms is tripped.

Status indicators: Max, Min, FZ, TZ

Display max./min. value, Amber LED turns on at forced zero mode and tare adjustment mode

Function indicators

Hld: Turns on in green when HOLD signal is ON

TG: Turns on in green when TIMING signal is ON

NG: Blinking in green when a parameter is invalid

Zro: Turns on in green at zero setting of scaling setting mode

Spn: Turns on in green at span setting of scaling setting mode

TCH: Turns on in green at input scaling, blinking in red at teach calibration

Engineering unit indication: Sticker label attached

DC, AC, mV, V, kV, μ A, mA, A, kA, mW, W, kW, var, kvar, Mvar, VA, Hz, Ω , k Ω , M Ω , cm, mm, m, m/sec, mm/min, cm/min, m/min, m/h, m/s², inch, l, l/s, l/min, l/h, m³, m³/sec, m³/min, m³/h, Nm³/h, N·m, N/m², g, kg, kg/h, N, kN, Pa, kPa, MPa, t, t/h, °C, °F, %RH, J, kJ, MJ, rpm, sec, min, pH, %, ppm, etc.

EXCITATION SUPPLY**■ +12V SENSOR EXCITATION**

Output voltage (across the terminals 5 - 6): 12 - 16 V DC with no load

10.8 V DC minimum at 80 mA

Current rating: 84 mA DC maximum

• Shortcircuit Protection

Current limited: 97 mA maximum

Protected time duration: No limit

■ +24V TWO-WIRE TRANSMITTER EXCITATION

Output voltage (across the terminals 5 - 6): 24 - 28V DC with no load

22 V DC minimum at 20 mA

Current rating: \leq 22 mA DC

• Shortcircuit Protection

Current limited: 30 mA max.

Protected time duration: No limit

INPUT SPECIFICATIONS

VOLTAGE INPUT

TYPE ID	MEASURING RANGE	OPERATIONAL RANGE	INPUT IMPEDANCE
1-5 μ	1 – 5V	0.6 – 5.4V	1M Ω minimum
-5-5 μ	\pm 5V	-6 – +6V	1M Ω minimum
20 μ	\pm 20V	-24 – +24V	1M Ω minimum
200 μ	\pm 200V	-240 – +240V	1M Ω minimum

CURRENT INPUT

TYPE ID	MEASURING RANGE	OPERATIONAL RANGE	INPUT IMPEDANCE
4-20 $\bar{n}A$	4 – 20mA	2.4 – 21.6mA	10 Ω
0-20 $\bar{n}A$	0 – 20mA	-2 – +22mA	10 Ω
20 $\bar{n}A$	\pm 20mA	-24 – +24mA	10 Ω
200 $\bar{n}A$	\pm 200mA	-240 – +240mA	1 Ω

DC OUTPUT SIGNAL SPECIFICATIONS

VOLTAGE OUTPUT

TYPE ID	OUTPUT RANGE	OPERATIONAL RANGE	LOAD RESISTANCE
0-5 μ	0 – 5V	-0.5 – +5.5V	2000 Ω minimum
5 μ	\pm 5V	-6 – +6V	4000 Ω minimum
10 μ	\pm 10V	-12 – +12V	8000 Ω minimum

CURRENT OUTPUT

TYPE ID	OUTPUT RANGE	OPERATIONAL RANGE	LOAD RESISTANCE
0-20 $\bar{n}A$	0 – 20mA	-2 – +22mA	400 Ω maximum
4-20 $\bar{n}A$	4 – 20mA	2.4 – 21.6mA	400 Ω maximum

I/O OPTIONS

■ **Event Trigger Input:** Dry contact or NPN open collector

Input current: \leq 3 mA

Sensing: 6 V

Contact detecting: \leq 1.5 V at ON; \geq 3 V at OFF

Signal ID and Details

S-TMR: Startup Timer

Measuring starts in the predetermined time after detecting the signal turning on.

TIMING: Timing

Used for various timing hold functions

ZERO: Forced Zero

Forced Zero and tare adjustment are externally controlled when ZERO signal is turned on/off.

HOLD: Hold data

Reading measured signal stops and the last value is held when HOLD signal is turned on.

RESET: Reset data

The device is reset when RESET signal is turned on.

■ **Alarm Output:** Relay contact

Rated load: 250 V AC @ 3 A (cos θ = 1)

30 V DC @ 3 A (resistive load)

Maximum switching voltage: 250 V AC, 30 V DC

Maximum switching power: 750 VA, 90 W (resistive load)

Minimum load: 5 V DC @ 10 mA

Mechanical life: \geq 5 \times 10⁶ cycles (rate 180 cycles/min.)

■ **Alarm Output:** Photo MOS relay

Rated load: 120 V AC/DC @ 80 mA (resistive load)

ON resistance: 25 Ω

Permissible loss: 250 mW

■ **Network Interface**

Transmission: Half-duplex, asynchronous, no procedure

Interface: Conforms to EIA RS-485

Max. transmission distance: 500 meters

Baud rate: 1.2 – 38.4 kbps

Max. number of nodes: 31 (except the master)

Protocol: Modbus RTU

Parity: None, odd or even

Stop bit: 1 bit, 2 bits

Node address: 1 to 247

Media: Shielded twisted-pair cable (CPEV-S 0.9 dia.)

Terminating resistor: Built-in (Connect across T2 - T3, when the unit is the end of the line)

■ **BCD Output + Control Signals**

• **Input Signals:** Dry contact or NPN open collector

Input current: \leq 3 mA

Sensing: 6 V

Contact detecting: \leq 1.5 V at ON; \geq 3 V at OFF

Signal ID and Details

REQ: Request BCD data

Valid data in approx. 30 msec. after detecting the signal's rising edge

MIN_REQ: Request Minimum reading data

Valid data in approx. 30 msec. after detecting the signal's rising edge

MAX_REQ: Request Maximum reading data

Valid data in approx. 30 msec. after detecting the signal's rising edge

HOLD: Hold data

Reading measured signal stops and the last value is held when HOLD signal is turned on.

RESET: Reset data

All BCD data turn off when RESET signal is turned on.

• **Output Signals:** NPN open collector

Max. load voltage: 24 V DC

Max. load current: 10 mA

Saturation voltage: \leq 0.3 V

Leakage current: \leq 500 μ A

Signal ID and Details

DATA (Do 11...Do 68): BCD Output data in 6 digits

Do 1x = LSD ... Do 6x = 6th LSD

POL: BCD Polarity

ON = (-), OFF = (+)

OVF: BCD Overflow/underflow (scaling error)
Output given at overflow or underflow (scaling error)

DAV: Data Valid
ON = valid, OFF = invalid

RUN: Run
Means the meter is functioning.
OFF = Error except the scaling error
No DAV or DATA output is given when
RUN signal is not provided.

- **Alarm Output Signals:** NPN open collector

Max. load voltage: 24 V DC

Max. load current: 50 mA

Saturation voltage: ≤ 1.1 V

Leakage current: $\leq 500\mu\text{A}$

Signal ID and Details

HH: HH alarm trip output

H: H alarm trip output

PASS: PASS zone output

L: L alarm trip output

LL: LL alarm trip output

INSTALLATION

Power consumption

• **AC:** Max. 12 VA

• **DC:** 3.5 W max.

Operating temperature: -10 to +55°C (14 to 131°F)

Operating humidity: 30 to 90 %RH (non-condensing)

Mounting: Panel flush mounting

Weight: 300 g (0.66 lb)

PERFORMANCE

Accuracy

Display Voltage input: ± 0.03 % ± 1 digit

Current input: ± 0.1 % ± 1 digit

Output: ± 0.1 % (DC output = display + output)

Temp. coefficient: ± 0.015 %/°C (± 0.008 %/°F)

Input resolution: Max. 19 bits

Output resolution: Max. 14 bits

Response time: ≤ 0.5 sec.

(alarm output: 0 - 100 % at 90 % setpoint)

≤ 0.5 sec. (DC output: 0 - 90 %)

Line voltage effect: ± 0.1 % over voltage range

Insulation resistance: ≥ 100 M Ω with 500 V DC

Dielectric strength: 2000 V AC @ 1 minute

(input or excitation supply to DC output to HH output or H output to L output or LL output to network or BCD output or event trigger input to power to ground)

EXTERNAL VIEW

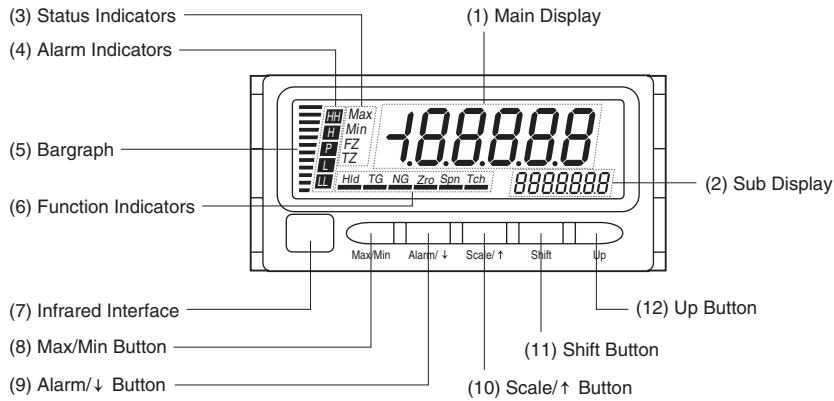

• COMPONENT IDENTIFICATION

No.	COMPONENT	FUNCTION
(1)	Main display	Indicates present values, setting values and status of the unit.
(2)	Sub display	Indicates the present setting mode.
(3)	Status indicators	Indicate Max/Min display mode, Forced zero mode and Tare adjustment mode.
(4)	Alarm indicators	Indicate alarm status of the input signal.
(5)	Bargraph	Indicates present signal level against the scaled range.
(6)	Function indicators	Indicate the device status.
(7)	Infrared interface	Used for the infrared communication.
(8)	Max/Min button	Used to switch the main display to show present values, maximum values or minimum values.
(9)	Alarm/↓ button	Used to confirm alarm setpoints, to move on to the alarm setting mode; or to shift through setting items in each setting mode.
(10)	Scale/↑ button	Used to move on to the scaling setting mode etc.; or to shift through setting items in each setting mode.
(11)	Shift button	Used to move on to the setting standby status and shift through display digits in each setting item.
(12)	Up button	Used to change and apply setting values; or to execute/cancel Forced Zero and tare adjustment.

Refer to the instruction manual for details on each function.

COMMUNICATION CABLE CONNECTIONS

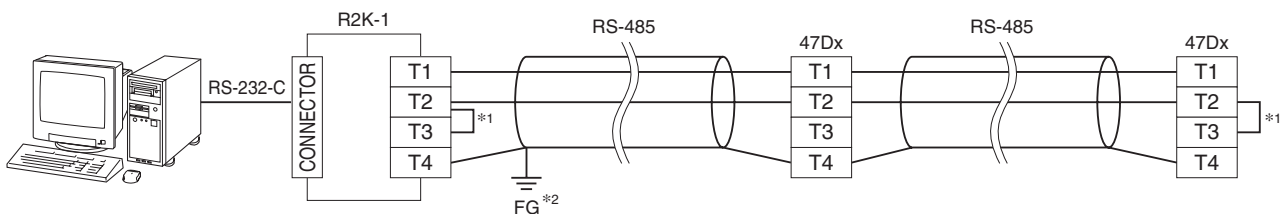

*1. Internal terminating resistor is used when the device is at the end of a transmission line.

*2. Install shield cables to all sections and ground them at single point.

EXTERNAL DIMENSIONS & TERMINAL ASSIGNMENTS unit: mm (inch)

■ TOP VIEW

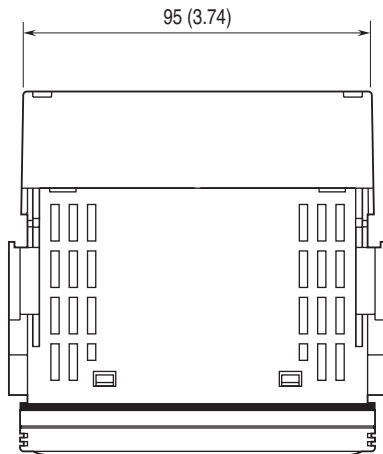

■ FRONT VIEW

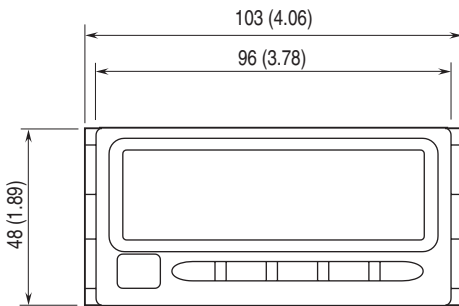

■ SIDE VIEW

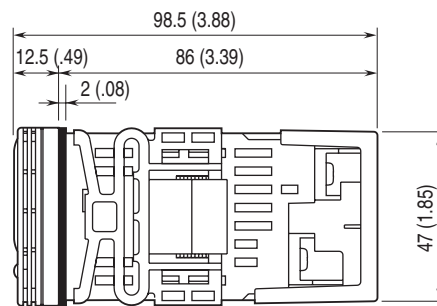

■ REAR VIEW

• No Options

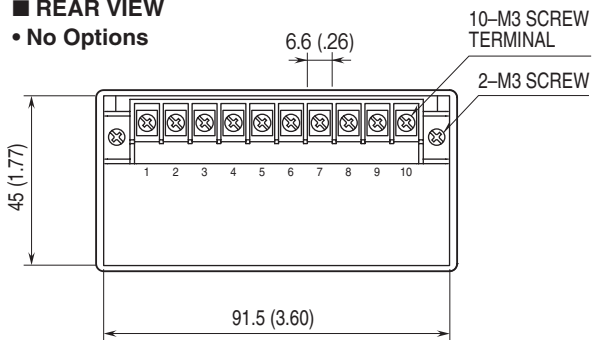

• Alarm Output, RS-485/Modbus

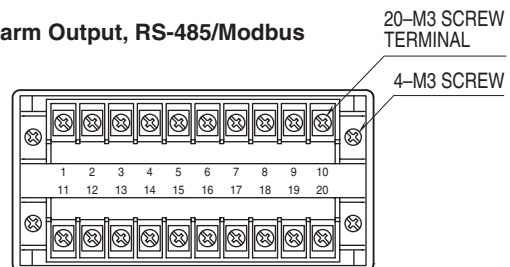

• BCD Output, Event Trigger Input, Alarm Output (Photo MOS Relay)

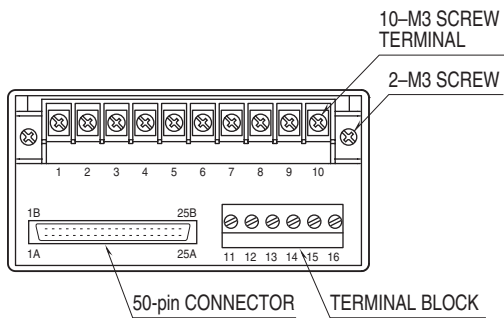

MOUNTING REQUIREMENTS unit: mm

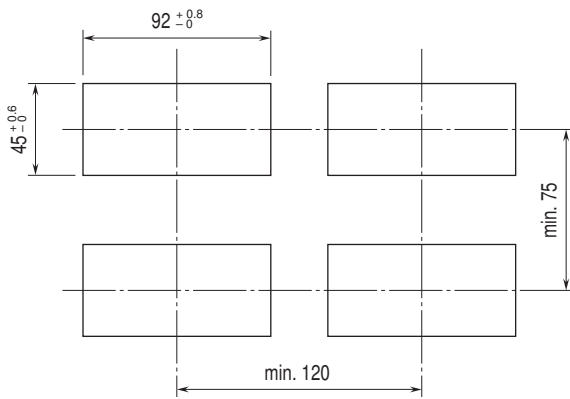

Panel thickness: 1.6 to 8.0 mm

SCHEMATIC CIRCUITRY & CONNECTION DIAGRAM

■ REAR TERMINAL ASSIGNMENTS

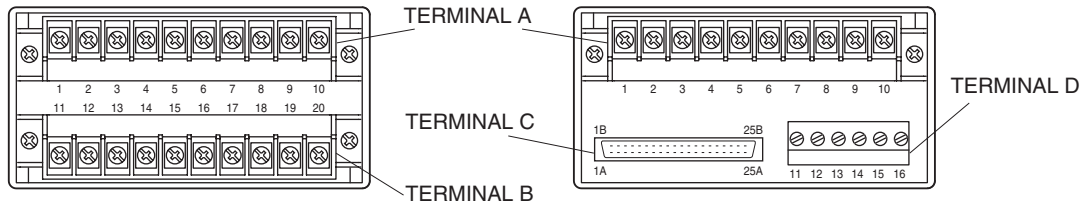

■ TERMINAL A : BASIC

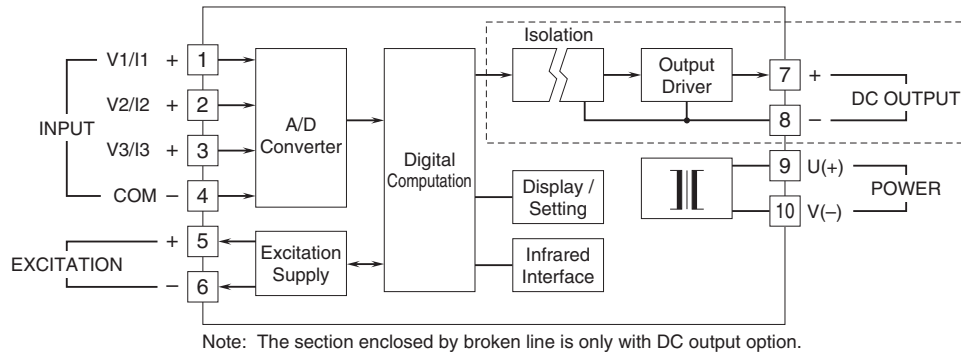

• Input Terminal Assignments

TYPE ID	MEASURING RANGE	INPUT TERMINALS
1-5 μ	1 - 5V	③ - ④
-5-5 μ	\pm 5V	③ - ④
20 μ	\pm 20V	② - ④
200 μ	\pm 200V	① - ④

TYPE ID	MEASURING RANGE	INPUT TERMINALS
4-20mA	4 - 20mA	③ - ④
0-20mA	0 - 20mA	③ - ④
20mA	\pm 20mA	② - ④
200mA	\pm 200mA	① - ④

• Excitation Supply Connection Examples

+12V Sensor Excitation

Isolate between the sensor output and the excitation supply.

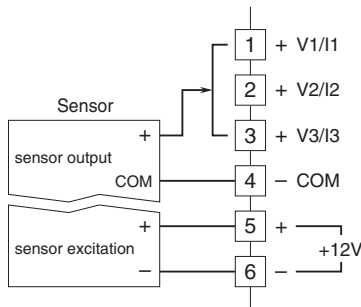

+24V Two-wire Transmitter Excitation

For use with a smart transmitter (e.g. HART), choose 'DC voltage input' and 'two-wire transmitter excitation' when ordering, and then connect as shown below.

Non-smart transmitters are also usable.

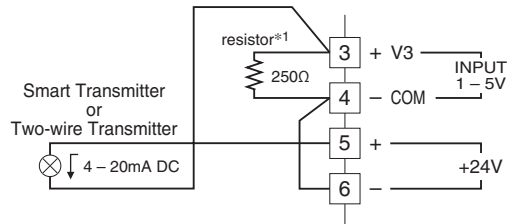

The configuration as shown below is possible for sensor outputs 1 - 5V or 4 - 20mA (no signal flow toward (-) direction)

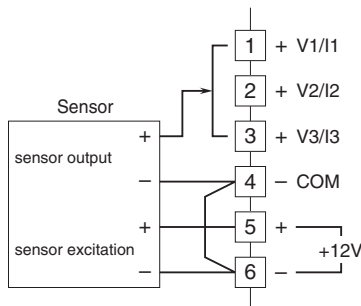

*1. Resistor module (model: REM2-250) is provided separately. Attach the REM2 to the terminals 3 - 4 as shown below.

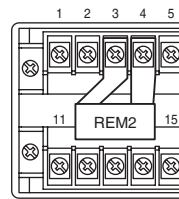

Recommended ring tongue terminal

R1.25-3

Terminals with insulation sleeve do not fit.

Applicable wire size 0.3 to 1.25 mm²

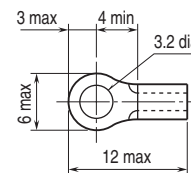

■ TERMINAL B

• Alarm Output : N.O. contact, 4 points

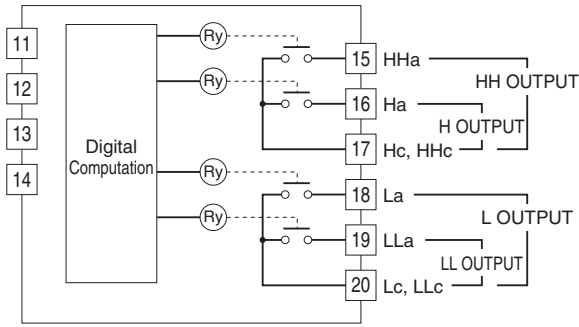

• Alarm Output : SPDT contact, 2 points

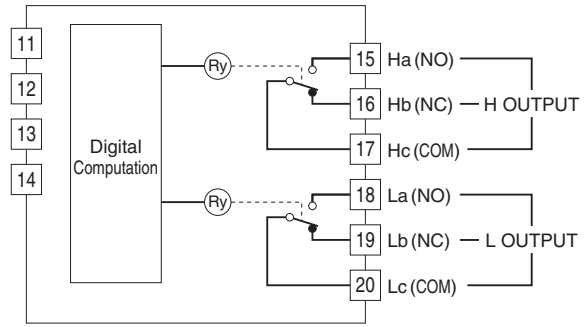

• RS-485 / Modbus RTU

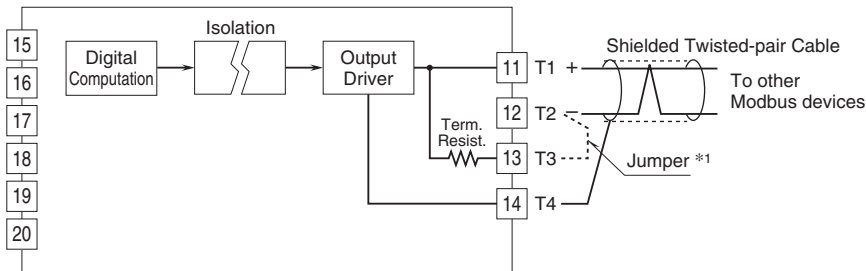

*1. When the device is located at the end of a transmission line via twisted-pair cable, (when there is no cross-wiring), close across the terminal 12 - 13 with a leadwire. When the device is not at the end, no shortcircuit wire is required.

■ Relay Protection

• AC Powered

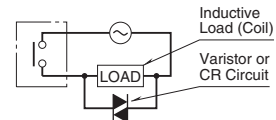

• DC Powered

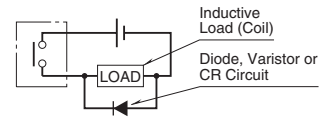

■ TERMINAL C : BCD OUTPUT

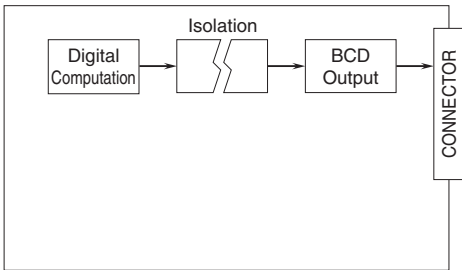

• Connector Pin Assignment



PIN NO.	ASSIGNMENT	PIN NO.	ASSIGNMENT
1A	COM	1B	Do 38
2A	COM	2B	COM
3A	LL	3B	Do 34
4A	L	4B	COM
5A	PASS	5B	Do 32
6A	H	6B	COM
7A	HH	7B	Do 31
8A	POL	8B	COM
9A	RESET	9B	Do 28
10A	HOID	10B	COM
11A	MIN_REQ	11B	Do 24
12A	MAX_REQ	12B	COM
13A	REQ	13B	Do 22
14A	COM	14B	COM
15A	RUN	15B	Do 21
16A	DAV	16B	Do 68
17A	OVF	17B	Do 18
18A	Do 58	18B	Do 64
19A	Do 54	19B	Do 14
20A	Do 52	20B	Do 62
21A	Do 51	21B	Do 12
22A	Do 48	22B	Do 61
23A	Do 44	23B	Do 11
24A	Do 42	24B	COM
25A	Do 41	25B	COM

• Open collector

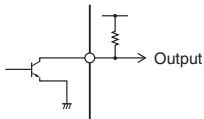

• Output Logic

Voltage Level at ON	Output Logic
Hi	Positive
Lo	Negative

• Connected to a digital display (example)

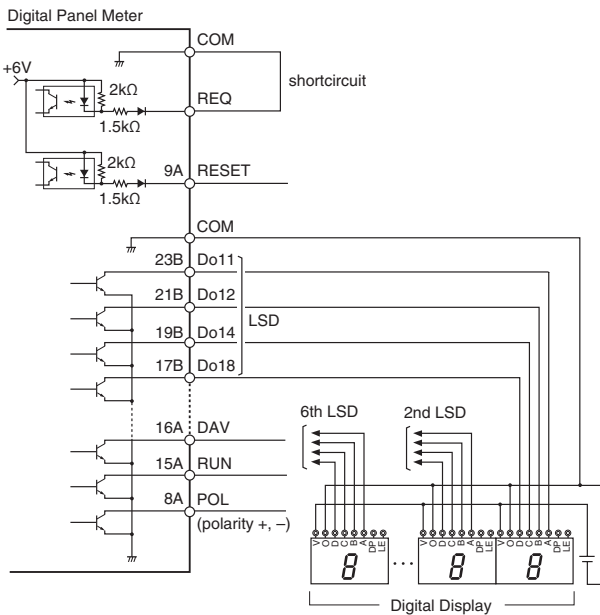

Use Special cable (model: HDR40) and Connector Terminal Block (model: CNT).
Refer to the cable's data sheet for pin assignments.

• Connected to a PLC (example)

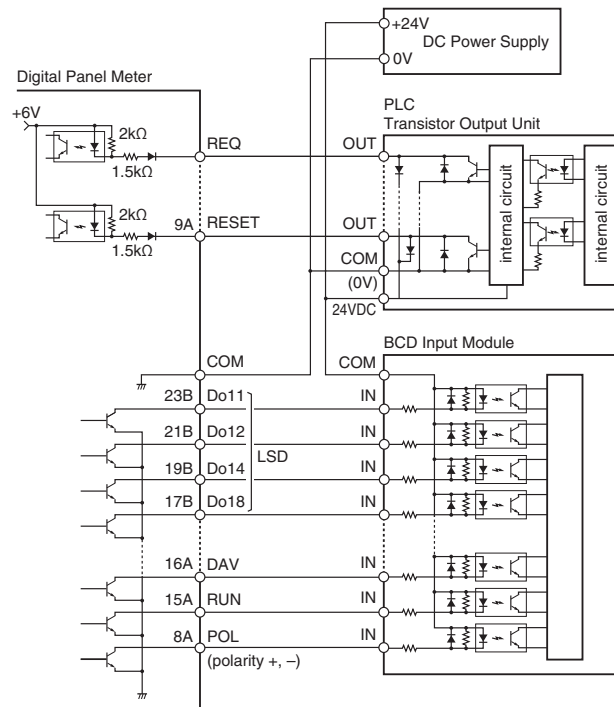

■ TERMINAL D

- Alarm Output : Photo MOS Relay N.O. contact, 4 points

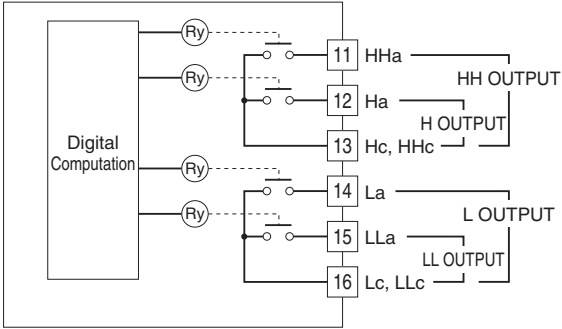

- Event Trigger Input

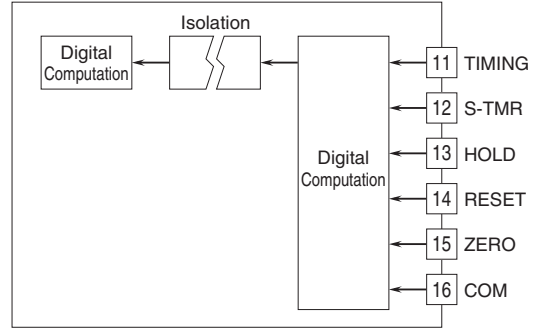

Connection Example

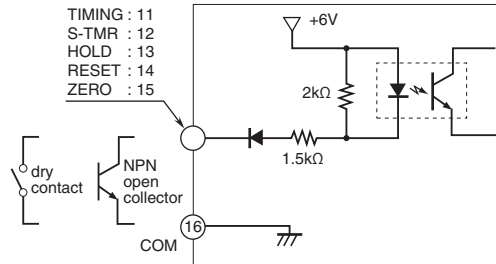

BCD OUTPUT TIMING CHART

Request signals (REQ, MAX_REQ, MIN_REQ) from an external device (e.g. PLC) are required in order to read out BCD data. All signals in the following charts are in the negative logic (ON at LOW signal, as factory set).

• Timing Chart for Continuous Data Output

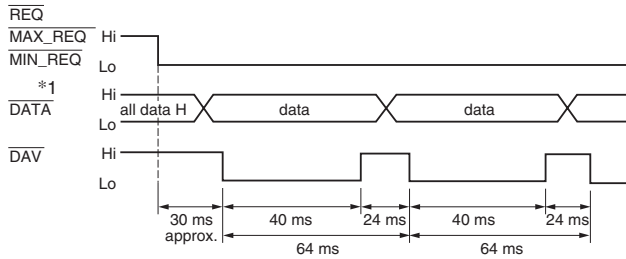

Measured data is output every 64 ms while one of REQ signals (REQ, MAX_REQ or MIN_REQ) remains ON. For Event trigger modes, the data value is the same as the display.

• Timing Chart for Single Sampling Cycle Data Output

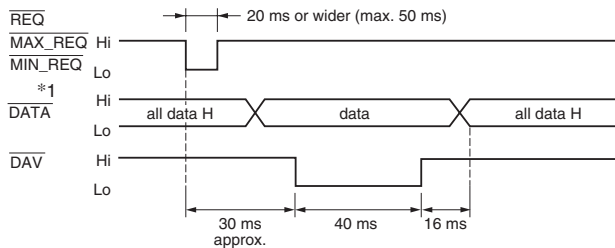

When one of REQ signals (REQ, MAX_REQ or MIN_REQ) is given and its width is between 20 and 50 ms, DATA is established and DAV output is given in approx. 30 ms from the falling edge of the REQ signal. Read in the data to a PLC at the timing of the DAV output signal. DAV is turned off in 40 ms. DATA is turned off in 16 ms after that.

• Output is provided via open collector, enabling wired-OR gate configuration

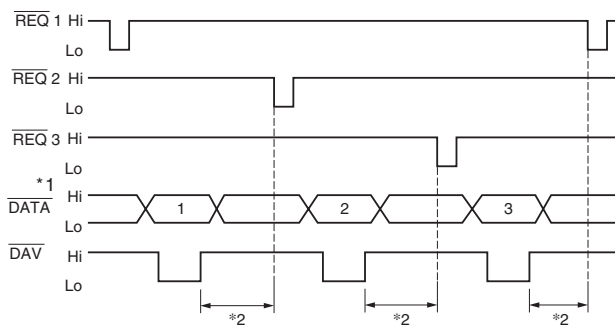

When DATA output logic is negative, wired-OR connection is available for BCD data, POL, OVF, HH, H, P, L and LL signals.

*1. DATA includes BCD Output, POL, OVF, HH, H, P, L, LL and RUN.

*2. Wait for at least 20 ms between DAV turning off and the next REQ signal.

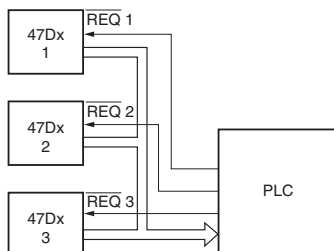

VIEWING ANGLE

The display is designed to provide the optimal legibility when viewed from the angles as shown below.

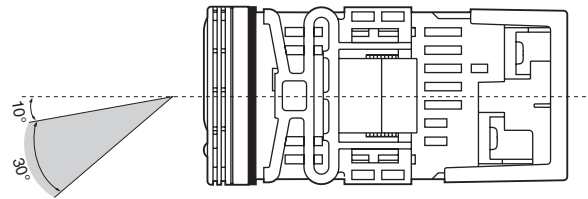

SYSTEM CONFIGURATION EXAMPLES

■ RS-485 / RS-232-C

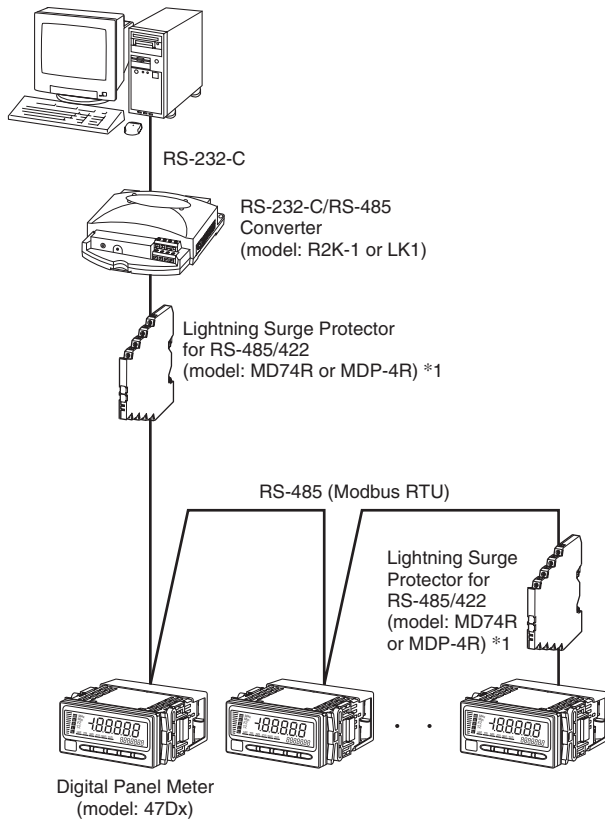

■ RS-485 / ETHERNET

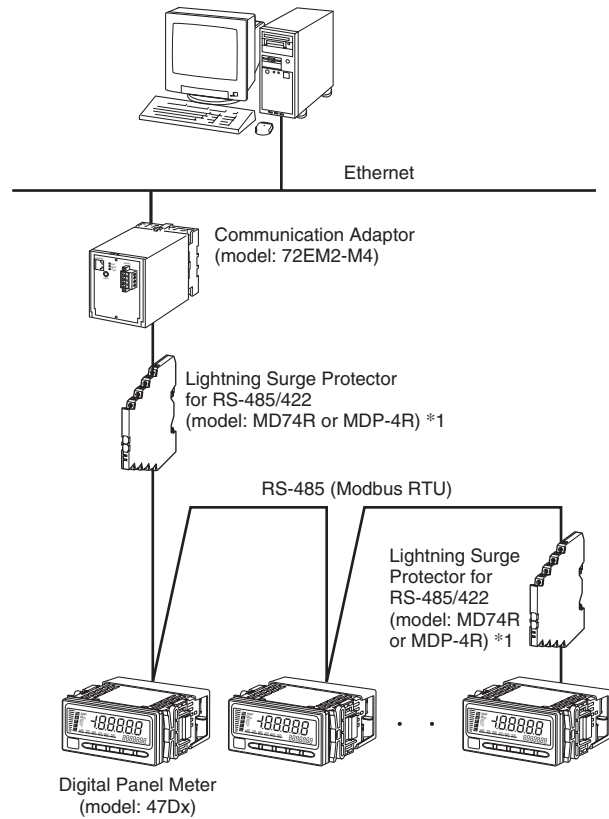

*1. Insert lightning surge protectors recommended in this example if necessary.



Specifications are subject to change without notice.