

THERMOCOUPLE TRANSMITTER
(PC programmable)

MODEL **M2EXT**

BEFORE USE

Thank you for choosing M-System. Before use, please check contents of the package you received as outlined below.

If you have any problems or questions with the product, please contact M-System's Sales Office or representatives.

■ PACKAGE INCLUDES:

Signal conditioner (body + base socket + CJM).....(1)

■ MODEL NO.

Confirm Model No. marking on the side of the product to be exactly what you ordered.

■ INSTRUCTION MANUAL

This manual describes necessary points of caution when you use this product, including installation, connection and detailed operation regarding settings. For detailed explanations, please refer to the Model M2EXT operating manual (EM-5145-B).

The M2EXT is programmable using a PC. For detailed information on the PC configuration, refer to the M2ECFG users manual (EM-5147).

The M2ECFG Configurator Software and the operating manual (EM-5145-B) are downloadable at M-System's web site: <http://www.m-system.co.jp>

POINTS OF CAUTION

■ CONFORMITY WITH EU DIRECTIVES

- This equipment is suitable for Pollution Degree 2 and Installation Category II. Reinforced insulation (signal input or output to power input: 300V) and basic insulation (signal input to output: 300V) are maintained. Prior to installation, check that the insulation class of this unit satisfies the system requirements.
- Altitude up to 2000 meters.
- The equipment must be mounted inside a panel.
- The equipment must be installed such that appropriate clearance and creepage distances are maintained to conform to CE requirements. Failure to observe these requirements may invalidate the CE conformance.
- The actual installation environments such as panel configurations, connected devices, connected wires, may affect the protection level of this unit when it is integrated in a panel system. The user may have to review the CE requirements in regard to the whole system and employ additional protective measures to ensure the CE conformity.
- Install lightning surge protectors for those wires connected to remote locations.

■ POWER INPUT RATING & OPERATIONAL RANGE

Locate the power input rating marked on the product and confirm its operational range as indicated below:

- 100 – 240V AC rating: 85 – 264V, 47 – 66 Hz,
 - ≤ 4.5VA at 100V AC
 - ≤ 6.5VA at 200V AC
 - ≤ 8.5VA at 264V AC

- 24V DC rating: 24V ±10%, ≤ 2.3W
- 110V DC rating: 85 – 150V, ≤ 2.3W

■ GENERAL PRECAUTIONS

Before you remove the unit from the socket or mount it, turn off the power supply and input signal for safety.

■ ENVIRONMENT

- Indoor use
- When heavy dust or metal particles are present in the air, install the unit inside proper housing with sufficient ventilation.
- Do not install the unit where it is subjected to continuous vibration. Do not subject the unit to physical impact.
- Environmental temperature must be within -5 to +55°C (23 to 131°F) with relative humidity within 10 to 85% RH in order to ensure adequate life span and operation.

■ WIRING

- Do not install cables close to noise sources (relay drive cable, high frequency line, etc.).
- Do not bind these cables together with those in which noises are present. Do not install them in the same duct.

■ AND

- The unit is designed to function as soon as power is supplied, however, a warm up for 10 minutes is required for satisfying complete performance described in the data sheet.
- With voltage output, do not leave the output terminals shortcircuited for a long time. The unit is designed to endure it without breakdown, however, it may shorten appropriate life duration.
- The edge of the display may be hidden by the frame and invisible depending on the view angle.

COMPONENT IDENTIFICATION

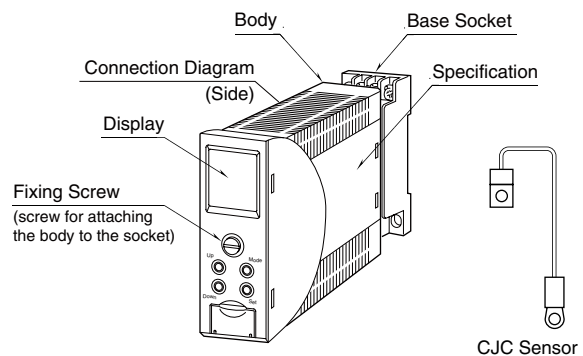

INSTALLATION

Loosen the fixing screw in front of the unit in order to separate the body from the base socket.

■ FIXING SCREW

The fixing screw can be pushed into the body when it is not in use. Tighten the knob until the body is securely attached to the base socket. Push it into the body and turn it clockwise to lock. Push the knob and turn it counterclockwise to unlock so that the knob pops out.

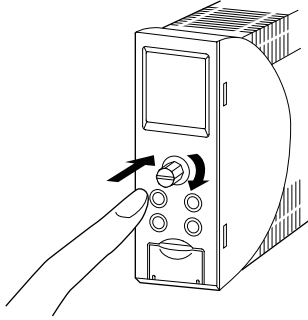

■ DIN RAIL MOUNTING

Set the base socket so that its DIN rail adaptor is at the bottom. Position the upper hook at the rear side of base socket on the DIN rail and push in the lower. When removing the socket, push down the DIN rail adaptor utilizing a minus screwdriver and pull.

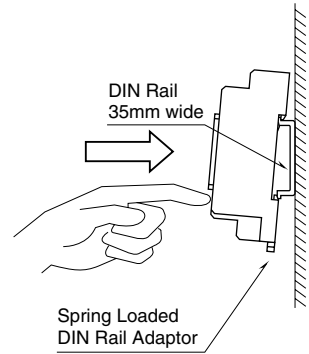

■ WALL MOUNTING

Refer to the drawings in the shown below.

TERMINAL CONNECTIONS

Connect the unit as in the diagram below or refer to the connection diagram on the side of the unit.

■ EXTERNAL DIMENSIONS unit: mm (inch)

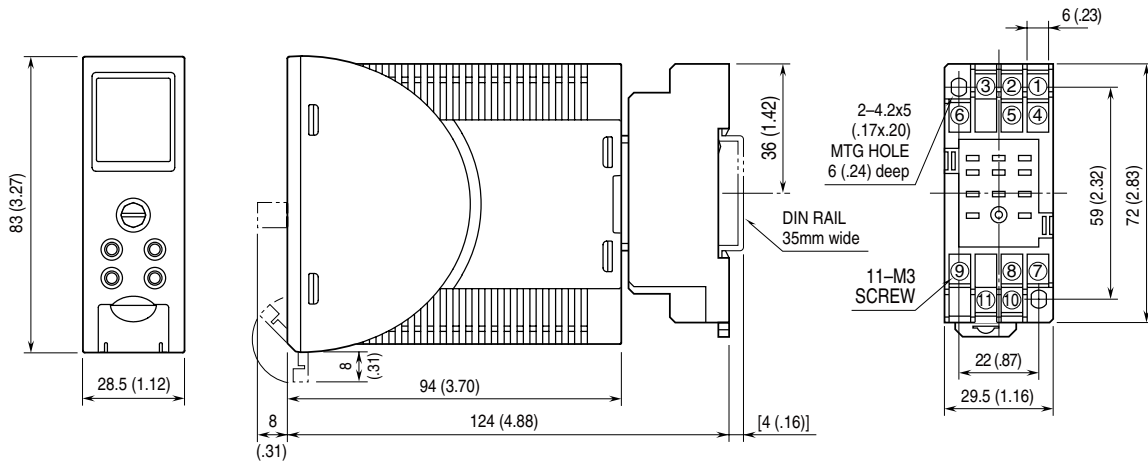

■ CONNECTION DIAGRAM

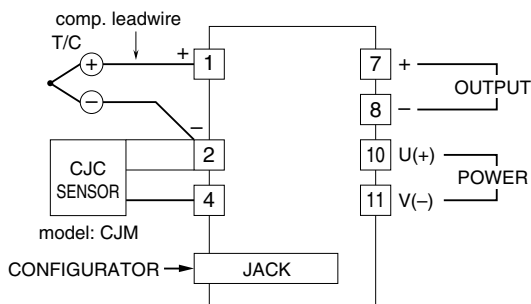

■ TERMINAL ASSIGNMENTS

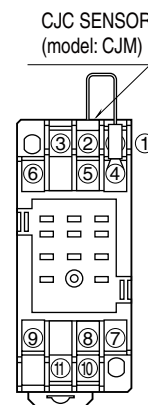

EXTERNAL VIEWS

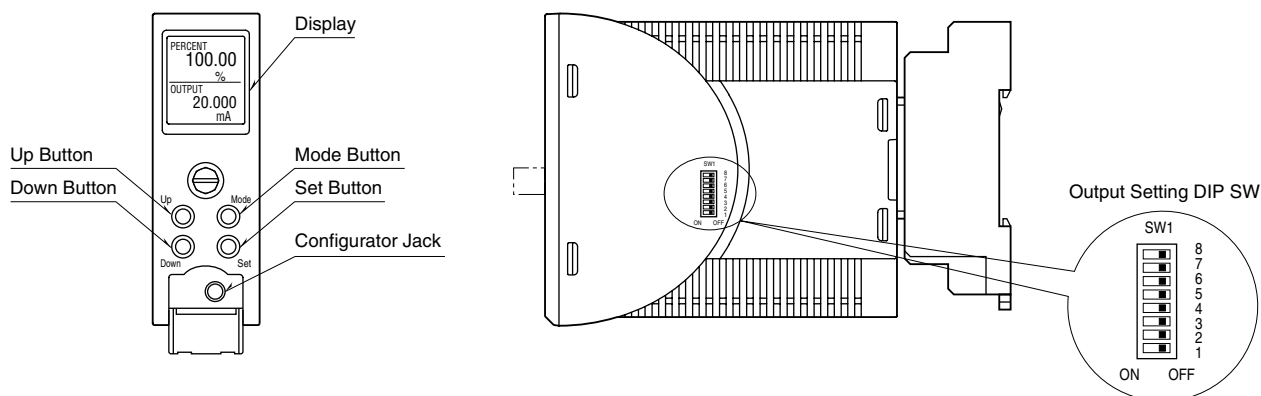

COMPONENT	FUNCTION
Display	Indicates present values, setting values and abnormal information. Two types of present values at upper and lower are displayed by setting.
Mode Button	Used to shift from measuring mode to each setting mode. Destination to shift is changed by the time pressing and holding the button. Used to return from each setting mode to measuring mode. (press and hold for 2 sec. or more)
Set Button	Used to change setting value of setting parameter. When at setting changeable state, used to enter (save) the setting value. Used to move on through digits of setting value for input/output scaling at setting changeable state,
Up Button	Used to shift through setting parameter, and to increase or select setting value.
Down Button	Used to shift through setting parameter, and to decrease or select setting value.
Configurator Jack	Used to configure with M2E configurator software (model: M2ECFG). At the same time, set the lock-out setting of the unit to 'lock'.

DIP SWITCH

The internal DIP switch for output setting is required to select output types before setting a precise output range using front buttons or setting with a PC.

Refer to the operating manual (EM-5145-B) for the operation with front buttons. Refer to the users manual (EM-5147) of M2E Configurator Software (model: M2ECFG) for setting with PC.

Output Type	SW1							
	1	2	3	4	5	6	7	8
0-20mA	OFF	ON	OFF	OFF	OFF	OFF	ON	OFF
-5-+5V	OFF	OFF	ON	OFF	ON	OFF	OFF	ON
-10-+10V	OFF	OFF	ON	OFF	OFF	ON	OFF	ON

CAUTION: DO NOT set DIP switches while power is supplied. Otherwise, the unit may fail.

WIRING INSTRUCTIONS

■ SCREW TERMINAL

Torque: 0.8 N·m

■ SOLDERLESS TERMINAL

Refer to the drawing below for recommended ring tongue terminal size. Spade tongue type is also applicable. Applicable wire size: 0.25 to 1.65 mm² (AWG 22 to 16) Recommended manufacturer: Japan Solderless Terminal MFG.Co.Ltd, Nichifu Co.,ltd

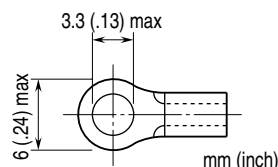

CHECKING

- 1) Terminal wiring: Check that all cables are correctly connected according to the connection diagram.
- 2) Check DIP switch setting.
- 3) Power input voltage: Check voltage across the terminal 10 – 11 with a multimeter.
- 4) Input: Check that the input signal is within 0 – 100% of the full-scale.
If the thermocouple or its extension wires are broken, the output goes over 100% (below 0% with downscale protection) due to the burnout function. Confirm the burnout error and check leadwires in such a case.
- 5) Output: Check that the load resistance meets the described specifications.

MAINTENANCE

Regular calibration procedure is explained below:

■ CALIBRATION

Warm up the unit for at least 10 minutes. Apply 0%, 25%, 50%, 75% and 100% input signal. Check that the output signal for the respective input signal remains within accuracy described in the data sheet. If the output signal is out of accuracy, when the input display value is out of accuracy, perform the input fine adjustment. When the input display value is correct but the output is out of accuracy, perform the output fine adjustment. Refer to this manual, when adjusting with front buttons. Refer to the M2E CFG users manual (EM-5147), when adjusting with M2E Configurator Software (model: M2E CFG). And then follow the procedure shown below.

• INPUT FINE ADJUSTMENT

- 1) Set the input signal to 0 %, and adjust the input display to 0 % by [69] Input Zero fine adjust.
- 2) Set the input signal to 100 %, and adjust the input display to 100 % by [70] Input Span fine adjust.
- 3) Again set the simulated input to 0 %, confirm the input display.
- 4) If input display is shifted, repeat the procedure from 1) to 3).

• OUTPUT FINE ADJUSTMENT

- 1) Set the simulated input to 0 %, and adjust the output signal to 0 % by [71] Output Zero fine adjust.
- 2) Set the simulated input to 100 %, and adjust the output signal to 100 % by [72] Output Span fine adjust.
- 3) Again set the simulated input to 0 %, confirm the output signal.
- 4) If output signal is shifted, repeat the procedure from 1) to 3).

LIGHTNING SURGE PROTECTION

M-System offers a series of lightning surge protector for protection against induced lightning surges. Please contact M-System to choose appropriate models.