

ATV900 DC Bus Sharing Technical Note

06/2019

This document describes how to design applications using ATV900 series drives on a common DC bus

The information provided in this documentation contains general descriptions and/or technical characteristics of the performance of the products contained herein. This documentation is not intended as a substitute for and is not to be used for determining suitability or reliability of these products for specific user applications. It is the duty of any such user or integrator to perform the appropriate and complete risk analysis, evaluation and testing of the products with respect to the relevant specific application or use thereof. Neither Schneider Electric nor any of its affiliates or subsidiaries shall be responsible or liable for misuse of the information contained herein. If you have any suggestions for improvements or amendments or have found errors in this publication, please notify us.

You agree not to reproduce, other than for your own personal, noncommercial use, all or part of this document on any medium whatsoever without permission of Schneider Electric, given in writing. You also agree not to establish any hypertext links to this document or its content. Schneider Electric does not grant any right or license for the personal and noncommercial use of the document or its content, except for a non-exclusive license to consult it on an "as is" basis, at your own risk. All other rights are reserved. All pertinent state, regional, and local safety regulations must be observed when installing and using this product. For reasons of safety and to help ensure compliance with documented system data, only the manufacturer should perform repairs to components.

When devices are used for applications with technical safety requirements, the relevant instructions must be followed.

Failure to use Schneider Electric software or approved software with our hardware products may result in injury, harm, or improper operating results.

Failure to observe this information can result in injury or equipment damage.

© 2019 Schneider Electric. All rights reserved.

Table of Contents

Table of Contents	2
Safety Information	3
NOTICE	3
PLEASE NOTE	3
Qualification Of Personnel	4
Intended Use	4
Product Related Information	4
About the book	8
Related document	8
Terminology	8
Preamble	9
General instructions when using a common DC link	10
Input voltage	10
Short circuit detection	10
Disconnection from the DC bus.	10
Input phase loss	10
Ground fault detection	10
EMC	10
Group definition for drives association	10
Wiring	11
Drives supplied by the AC mains	12
Drives supplied by the DC terminals	13
Drives supplied by the DC outputs of another drive	13
Drive supplied by a DC power supply	14
Using a braking unit on a common DC bus.	16
Braking resistor	16
Regenerative braking unit	19
Fuses table	21
IEC fuses table	21
UL fuses table	23
DC switch-disconnector.	25
Line chokes	27
External soft-charge circuit for drives of groups x2	29
Wiring Options	31
Wiring blocks	31

Safety Information



Important Information

NOTICE

Read these instructions carefully, and look at the equipment to become familiar with the device before trying to install, operate, or maintain it. The following special messages may appear throughout this documentation or on the equipment to inform of potential hazards or to call attention to information that clarifies or simplifies a procedure.



The addition of this symbol to a Danger safety label indicates that an electrical hazard exists, which will result in personal injury if the instructions are not followed.



This is the safety alert symbol. It is used to alert you to potential personal injury hazards. Obey all safety messages that follow this symbol to avoid possible injury or death.

⚠ DANGER

DANGER indicates a hazardous situation which, if not avoided, **will result in** death or serious injury.

⚠ WARNING

WARNING indicates a hazardous situation which, if not avoided, **could result in** death or serious injury.

⚠ CAUTION

CAUTION indicates a hazardous situation which, if not avoided, **could result in** minor or moderate injury.

NOTICE

NOTICE is used to address practices not related to physical injury.

PLEASE NOTE

Electrical equipment should be installed, operated, serviced, and maintained only by qualified personnel. No responsibility is assumed by Schneider Electric for any consequences arising out of the use of this material.

A qualified person is one who has skills and knowledge related to the construction and operation of electrical equipment and its installation, and has received safety training to recognize and avoid the hazards involved.

Qualification Of Personnel



Only appropriately trained persons who are familiar with and understand the contents of this manual and all other pertinent product documentation are authorized to work on and with this product. In addition, these persons must have received safety training to recognize and avoid hazards involved. These persons must have sufficient technical training, knowledge and experience and be able to foresee and detect potential hazards that may be caused by using the product, by changing the settings and by the mechanical, electrical and electronic equipment of the entire system in which the product is used. All persons working on and with the product must be fully familiar with all applicable standards, directives, and accident prevention regulations when performing such work.

Intended Use

This product is a drive for three-phase synchronous, asynchronous motors and intended for industrial use according to this manual. The product may only be used in compliance with all applicable safety standard and local regulations and directives, the specified requirements and the technical data. The product must be installed outside the hazardous ATEX zone. Prior to using the product, you must perform a risk assessment in view of the planned application. Based on the results, the appropriate safety measures must be implemented. Since the product is used as a component in an entire system, you must ensure the safety of persons by means of the design of this entire system (for example, machine design). Any use other than the use explicitly permitted is prohibited and can result in hazards.

Product Related Information

Read and understand these instructions before performing any procedure with this drive.

  **DANGER**

HAZARD OF ELECTRIC SHOCK, EXPLOSION OR ARC FLASH

- Only appropriately trained persons who are familiar with and understand the contents of this manual and all other pertinent product documentation and who have received safety training to recognize and avoid hazards involved are authorized to work on and with this drive system. Installation, adjustment, repair and maintenance must be performed by qualified personnel.
- The system integrator is responsible for compliance with all local and national electrical code requirements as well as all other applicable regulations with respect to grounding of all equipment.
- Many components of the product, including the printed circuit boards, operate with mains voltage.
- Only use properly rated, electrically insulated tools and measuring equipment.
- Do not touch unshielded components or terminals with voltage present.
- Motors can generate voltage when the shaft is rotated. Prior to performing any type of work on the drive system, block the motor shaft to prevent rotation.
- AC voltage can couple voltage to unused conductors in the motor cable. Insulate both ends of unused conductors of the motor cable.
- Do not short across the DC bus terminals or the DC bus capacitors or the braking resistor terminals.
- Before performing work on the drive system:
 - Disconnect all power, including external control power that may be present. Take into account that circuit breaker or main switch does not de-energize all circuits.
 - Place a **Do Not Turn On** label on all power switches related to the drive system.
 - Lock all power switches in the open position.
 - Wait 15 minutes to allow the DC bus capacitors to discharge.
 - Follow the instructions given in the chapter "Verifying the Absence of Voltage" in the installation manual of the product.
- Before applying voltage to the drive system:
 - Verify that the work has been completed and that the entire installation cannot cause hazards.
 - If the mains input terminals and the motor output terminals have been grounded and short-circuited, remove the ground and the short circuits on the mains input terminals and the motor output terminals.
 - Verify proper grounding of all equipment.
 - Verify that all protective equipment such as covers, doors, grids is installed and/or closed

Failure to follow these instructions will result in death or serious injury.

Damaged products or accessories may cause electric shock or unanticipated equipment operation.

DANGER
ELECTRIC SHOCK OR UNANTICIPATED EQUIPMENT OPERATION

Do not use damaged products or accessories.

Failure to follow these instructions will result in death or serious injury.

Contact your local Schneider Electric sales office if you detect any damage whatsoever.

This equipment has been designed to operate outside of any hazardous location. Only install this equipment in zones known to be free of hazardous atmosphere.

DANGER
POTENTIAL FOR EXPLOSION

Install and use this equipment in non-hazardous locations only.

Failure to follow these instructions will result in death or serious injury.

Your application consists of a whole range of different interrelated mechanical, electrical, and electronic components, the drive being just one part of the application. The drive by itself is neither intended to nor capable of providing the entire functionality to meet all safety-related requirements that apply to your application. Depending on the application and the corresponding risk assessment to be conducted by you, a whole variety of additional equipment is required such as, but not limited to, external encoders, external brakes, external monitoring devices, guards, etc.

As a designer/manufacturer of machines, you must be familiar with and observe all standards that apply to your machine. You must conduct a risk assessment and determine the appropriate Performance Level (PL) and/or Safety Integrity Level (SIL) and design and build your machine in compliance with all applicable standards. In doing so, you must consider the interrelation of all components of the machine. In addition, you must provide instructions for use that enable the user of your machine to perform any type of work on and with the machine such as operation and maintenance in a safe manner.

The present document assumes that you are fully aware of all normative standards and requirements that apply to your application. Since the drive cannot provide all safety-related functionality for your entire application, you must ensure that the required Performance Level and/or Safety Integrity Level is reached by installing all necessary additional equipment.

WARNING
INSUFFICIENT PERFORMANCE LEVEL/SAFETY INTEGRITY LEVEL AND/OR UNINTENDED EQUIPMENT OPERATION

- Conduct a risk assessment according to EN ISO 12100 and all other standards that apply to your application.
- Use redundant components and/or control paths for all critical control functions identified in your risk assessment.
- If moving loads can result in hazards, for example, slipping or falling loads, operate the drive in closed loop mode.
- Verify that the service life of all individual components used in your application is sufficient for the intended service life of your overall application.
- Perform extensive commissioning tests for all potential error situations to verify the effectiveness of the safety-related functions and monitoring functions implemented, for example, but not limited to, speed monitoring by means of encoders, short circuit monitoring for all connected equipment, correct operation of brakes and guards.
- Perform extensive commissioning tests for all potential error situations to verify that the load can be brought to a safe stop under all conditions

Failure to follow these instructions can result in death, serious injury, or equipment damage.

A specific application note [NHA80973](#) is available on hoisting machines and can be downloaded on www.se.com.

Drive systems may perform unexpected movements because of incorrect wiring, incorrect settings, incorrect data or other errors.

WARNING

UNANTICIPATED EQUIPMENT OPERATION

- Carefully install the wiring in accordance with the EMC requirements.
- Do not operate the product with unknown or unsuitable settings or data.
- Perform a comprehensive commissioning test.

Failure to follow these instructions can result in death, serious injury, or equipment damage.

WARNING

LOSS OF CONTROL

- The designer of any control scheme must consider the potential failure modes of control paths and, for critical control functions, provide a means to achieve a safe state during and after a path failure. Examples of critical control functions are emergency stop, overtravel stop, power outage and restart.
- Separate or redundant control paths must be provided for critical control functions.
- System control paths may include communication links. Consideration must be given to the implications of unanticipated transmission delays or failures of the link.
- Observe all accident prevention regulations and local safety guidelines (1).
- Each implementation of the product must be individually and thoroughly tested for proper operation before being placed into service. Failure to follow these instructions can result in death, serious injury, or equipment damage.

Failure to follow these instructions can result in death, serious injury, or equipment damage.

(1) For USA: Additional information, refer to NEMA ICS 1.1 (latest edition), Safety Guidelines for the Application, Installation, and Maintenance of Solid State Control and to NEMA ICS 7.1 (latest edition), Safety Standards for Construction and Guide for Selection, Installation and Operation of Adjustable-Speed Drive Systems.

The temperature of the products described in this manual may exceed 80 °C (176 °F) during operation.

WARNING

HOT SURFACES

- Ensure that any contact with hot surfaces is avoided.
- Do not allow flammable or heat-sensitive parts in the immediate vicinity of hot surfaces.
- Verify that the product has sufficiently cooled down before handling it.
- Verify that the heat dissipation is sufficient by performing a test run under maximum load conditions.

Failure to follow these instructions can result in death, serious injury, or equipment damage.

Machines, controllers, and related equipment are usually integrated into networks. Unauthorized persons and malware may gain access to the machine as well as to other devices on the network/fieldbus of the machine and connected networks via insufficiently secure access to software and networks.

 **WARNING****UNAUTHORIZED ACCESS TO THE MACHINE VIA SOFTWARE AND NETWORKS**

- In your hazard and risk analysis, consider all hazards that result from access to and operation on the network/fieldbus and develop an appropriate cyber security concept.
- Verify that the hardware infrastructure and the software infrastructure into which the machine is integrated as well as all organizational measures and rules covering access to this infrastructure consider the results of the hazard and risk analysis and are implemented according to best practices and standards covering IT security and cyber security (such as: ISO/IEC 27000 series, Common Criteria for Information Technology Security Evaluation, ISO/IEC 15408, IEC 62351, ISA/IEC 62443, NIST Cybersecurity Framework, Information Security Forum - Standard of Good Practice for Information Security).
- Verify the effectiveness of your IT security and cyber security systems using appropriate, proven methods.

Failure to follow these instructions can result in death, serious injury, or equipment damage.

 **WARNING****LOSS OF CONTROL**

- Perform a comprehensive commissioning test to verify that communication monitoring properly detects communication interruptions.

Failure to follow these instructions can result in death, serious injury, or equipment damage.

NOTICE**DESTRUCTION DUE TO INCORRECT MAINS VOLTAGE**

Before switching on and configuring the product, verify that it is approved for the mains voltage.

Failure to follow these instructions can result in equipment damage.

About the book

Related document

Use your tablet or your PC to quickly access detailed and comprehensive information on all our products on www.schneider-electric.com.

The internet site provides the information you need for products and solutions

- The whole catalog for detailed characteristics and selection guides
- The CAD files to help design your installation, available in over 20 different file formats
- All software and firmware to maintain your installation up to date
- A large quantity of White Papers, Environment documents, Application solutions, Specifications... to gain a better understanding of our electrical systems and equipment or automation
- And finally all the User Guides related to your drive, listed below:

Title of Documentation	Reference Number
ATV930, ATV950 Installation manual	NHA80932 (English), NHA80933 (French), NHA80934 (German), NHA80935 (Spanish), NHA80936 (Italian), NHA80937 (Chinese), NHA80932PT (Portuguese), NHA80932TR (Turkish)
ATV900 Programming manual	NHA80757 (English), NHA80758 (French), NHA80759 (German), NHA80760 (Spanish), NHA80761 (Italian), NHA80762 (Chinese), NHA80757PT (Portuguese), NHA80757TR (Turkish)
Altivar Regenerative Unit User manual	NVE88423 (English)
Altivar Regenerative Unit Sizing Tool	NVE94856 (English)

You can download these technical publications and other technical information from our website at <http://download.schneider-electric.com>

Terminology

The technical terms, terminology, and the corresponding descriptions in this manual normally use the terms or definitions in the relevant standards.

In the area of drive systems this includes, but is not limited to, terms such as **error**, **error message**, **failure**, **fault**, **fault reset**, **protection**, **safe state**, **safety function**, **warning**, **warning message**, and so on.

Among others, these standards include:

- IEC 61800 series: Adjustable speed electrical power drive systems
- IEC 61508 Ed.2 series: Functional safety of electrical/electronic/programmable electronic safety-related
- EN 954-1 Safety of machinery - Safety related parts of control systems
- EN ISO 13849-1 & 2 Safety of machinery - Safety related parts of control systems.
- IEC 61158 series: Industrial communication networks - Fieldbus specifications
- IEC 61784 series: Industrial communication networks - Profiles
- IEC 60204-1: Safety of machinery - Electrical equipment of machines - Part 1: General requirements

In addition, the term **zone of operation** is used in conjunction with the description of specific hazards, and is defined as it is for a **hazard zone** or **danger zone** in the EC Machinery Directive (2006/42/EC) and in ISO 12100-1.

Also see the glossary at the end of this manual.

Preamble

The document defines the rules to be applied to link ATV900 drives range on a common DC bus. It also gives the limits of the DC bus connection.

The main target to use a common DC bus is to save energy, as the braking energy of one drive operating in generator mode can be re-used by another drive operating in motor mode instead of dissipating it in heat into a braking resistor. It means that the key point to decide to use a DC bus connection is to define the drives cycles. **The DC bus connection has no sense if all drives are all operating in generator mode or in motor mode at the same time.** The first step is to estimate the benefits to use a DC bus connection regarding the drives cycles.

Sharing the DC bus and adjusting the drive cycles to reduce the braking energy during normal operation could also lead to a reduction of the number of braking resistors to use in the application. In order to take advantages of using a common DC bus it is necessary to verify that energy is shared during cycles. The diagram below shows a cycle where energy can be saved when one drive is operating in motor mode and another one operating in braking mode.

When some drives linked on the DC bus are braking and the other drives linked on the DC bus cannot re-use the braking energy, excess energy must be either dissipated in a braking resistor or pushed back to the mains power supply using a regenerative unit. See section "Using a braking unit on a common DC bus"

It is also necessary to consider if some emergency operating modes like "fast stop" or "emergency stop" are required by the application, which will need the full power braking capability of all drives at the same time. This situation cannot lead to braking resistors reduction.

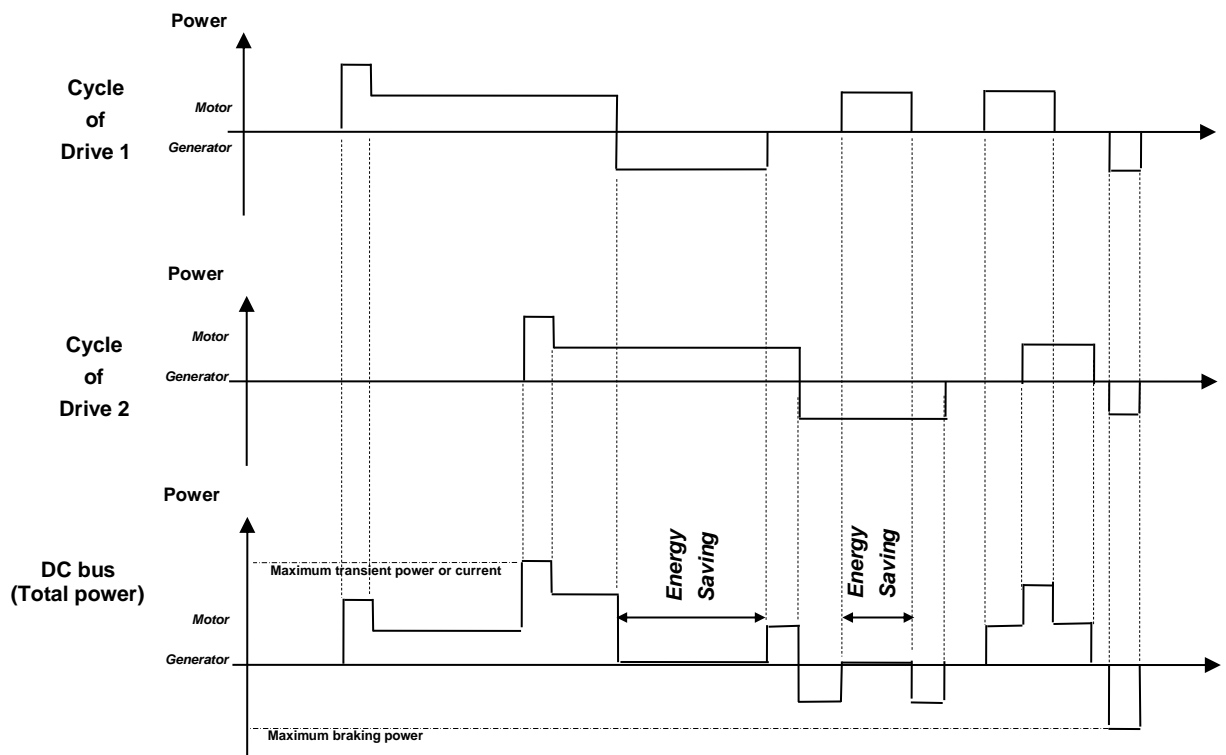

NOTE: If the use cases detailed in this technical note does not correspond to your application, or if you need more support, contact your Customer Care Center.

General instructions when using a common DC link

Input voltage

Only drives having **the same input voltage range** can share the same DC bus. ATV9x0 drives have two mains voltage ranges:

- 200 / 240 V 3-phase for ATV9x0xxxM3x references,
- 400 / 480 V 3-phase for ATV9x0xxxN4x references.

ATV9x0xxxM3x drives and ATV9x0xxxN4x drives must never share the same DC bus.

Short circuit detection

The aim of this detection is to **help to protect other drives** from an internal DC short-circuit in one of the drives linked on the common DC link.

Usually, each drive has to be connected to the DC common link by **2 fuses selected in the semi-conductor protection class**, which have the capability to clear a DC current.

Disconnection from the DC bus.

To easily disconnect one drive from the DC bus while others are in operation, the drives can be wired to the DC bus through a **DC voltage switch-disconnector** as shown in the drawings of this document. This device provides switch-on and switch-off on the DC-bus and isolation from the DC-bus voltage when it is switched-off to allow the replacement of the fuses or of the drive.

The DC voltage switch-disconnector to be associated with the drives are listed in the section "SC switch-disconnector" at the end of this document

Input phase loss

Input phase loss fault detection must be enabled on all the drive linked on the DC bus and fed by the AC main power supply. This is required to avoid that a low power drive to supply all the other though the DC bus link in case of mains power loss of high power drives.

When a drive is only fed by the DC bus link, the input phase loss fault must be disabled.

Ground fault detection

ATV900 ground fault detection does not need to be disabled.

EMC

When a common DC bus is used, conducted and radiated disturbances level cannot be at the same level as a drive alone. The application of the wiring recommendations of this document helps to minimize the increase of disturbances levels.

Group definition for drives association

All ATV900 ratings have an integrated DC choke to reduce the input current harmonics, which will also work as input currents balancing between drives linked on the same DC bus.

Drives are grouped according to the following table, depending on the characteristics of the input stage

- Input diodes or thyristors rectifier I²t
- Mains input voltage range 200 / 240 V or 400 / 480 V

Refer to the [ATV900 installation manual](#) for terminal location

Groups	Drives references	Input stage
A1	ATV9x0U07N4x ... ATV9x0D22N4x	400 V 3-phase, diodes, relay and charge resistor
A2	ATV9x0D30N4x ... ATV9x0C31N4x	400 V 3-phase, SCRs/diodes and soft-charge control
B1	ATV9x0U07M3x ... ATV9x0D11M3x	200 V 3-phase, diodes, relay and charge resistor
B2	ATV9x0D15M3x ... ATV9x0D45M3x	200 V 3-phase, SCRs/diodes and soft-charge control

Drives of groups Ax must never share the same DC bus with drives of groups Bx.

Wiring

All ATV9x0 drives are 380 ~ 480 V or 200 ~ 240V, 3-phase AC input voltage. When the drives share the same DC bus and are supplied at the same time by the mains on L1, L2 and L3 terminals, it must be by the **same power lines after the same mains transformer**.

In order to limit the over-voltages on the common DC bus while drives are operating, the following cabling rules must be respected:

- The total **cable length between PA/+ and PC/-** connections of one drive to PA/+ and PC/- connections of another drive **must be less than 2 m**.
- The ground wire included in the DC bus is optional. It is not a protective ground conductor (PE); it just helps to reduce the conducted and radiated emissions.
- The **distance between +DC and -DC wires must not exceed 5 cm** except close to the junctions' terminals, the switch-disconnector, the fuses holders or the drives PA/+ and PC/- to allow cabling. This is to avoid over-voltage on the DC link while the drives are operating.

To meet this requirement, it is possible to use one of the following solutions:

- Independent cables with cable clamps,
- Two or three-wires sheathed cable,
- Or 2-wires shielded cable where the shield is grounded.

Drives supplied by the AC mains

To protect the drives' input rectifiers in case of short-circuit on the DC bus link, **semi-conductor protection class fuses** must be selected from the table at the end of this document. The location of fuses depends on the type of drives used on the DC bus link.

All the drives sharing a common DC bus link must be switched-on at the same time to the mains power supply. If there is a delay between different switch-on, high power drive must be switched on before low power drives. This is to avoid low power drives to charge all the capacitors of the drives wired on the common DC bus.

When drives are fed by the AC mains, all the input rectifiers of the drives linked on the common DC bus are operating. To balance the input currents between drives, the rules described in this section must be applied.

All ATV900 drives have DC terminals similar to the input lines and motor output terminals. Same cables as those used for mains input lines can be used for DC bus connections.

The drive terminals cannot withstand the total DC-bus current and therefore cannot be used for chaining. **Wiring blocks must be used to build the DC bus link** and to wire each drive with only one wire for the PA/+ connection and one wire for the PC/- connection.

The wiring blocks can be selected in the Schneider-Electric catalog in the LINERGY product range as shown in the last section (Wiring options) of this document.

In order to limit the over-voltages on the common DC bus while drives are operating, the wiring recommendations listed at the beginning of this document must be applied.

The generic wiring diagram of this configuration is shown in the drawing below:

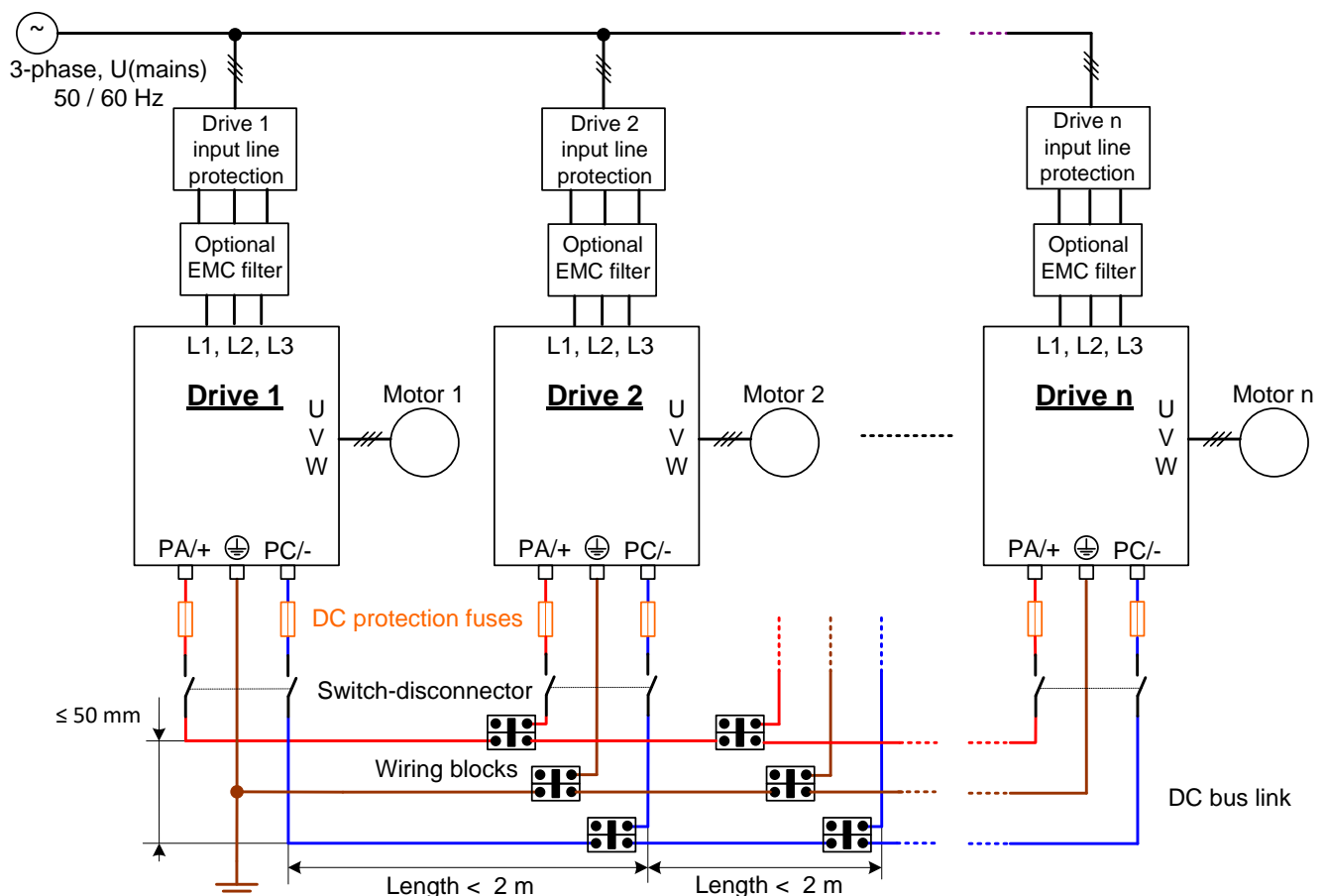

For $U(\text{mains}) = 400 / 480\text{ V}$, drives 1 ... n must belong to groups A1 or A2

For $U(\text{mains}) = 200 / 240\text{ V}$, drives 1 ... n must belong to groups B1 or B2

Drives supplied by the DC terminals

In this configuration, the drives are not supplied by the mains power supply, but only through the PA/+ terminal and the PC/- inputs. The DC source can be one of the following:

- A drive which a part of the power is provided to other drives through the DC bus,
- A dedicated DC power source device to provide DC voltage.

Drives supplied by the DC outputs of another drive

ATV900 can supply in a correct way a motor of minimum one third of the drive rated power. It means that the maximum power available to supply a DC bus is two third of the drive's power rating.

The drive which supplies the common DC bus of other drives must always use the input line choke listed in the section "Line chokes" at the end of this document, in order to limit the RMS input current due to increased capacitors value on the DC bus.

The generic cabling circuit is shown on the drawings below.

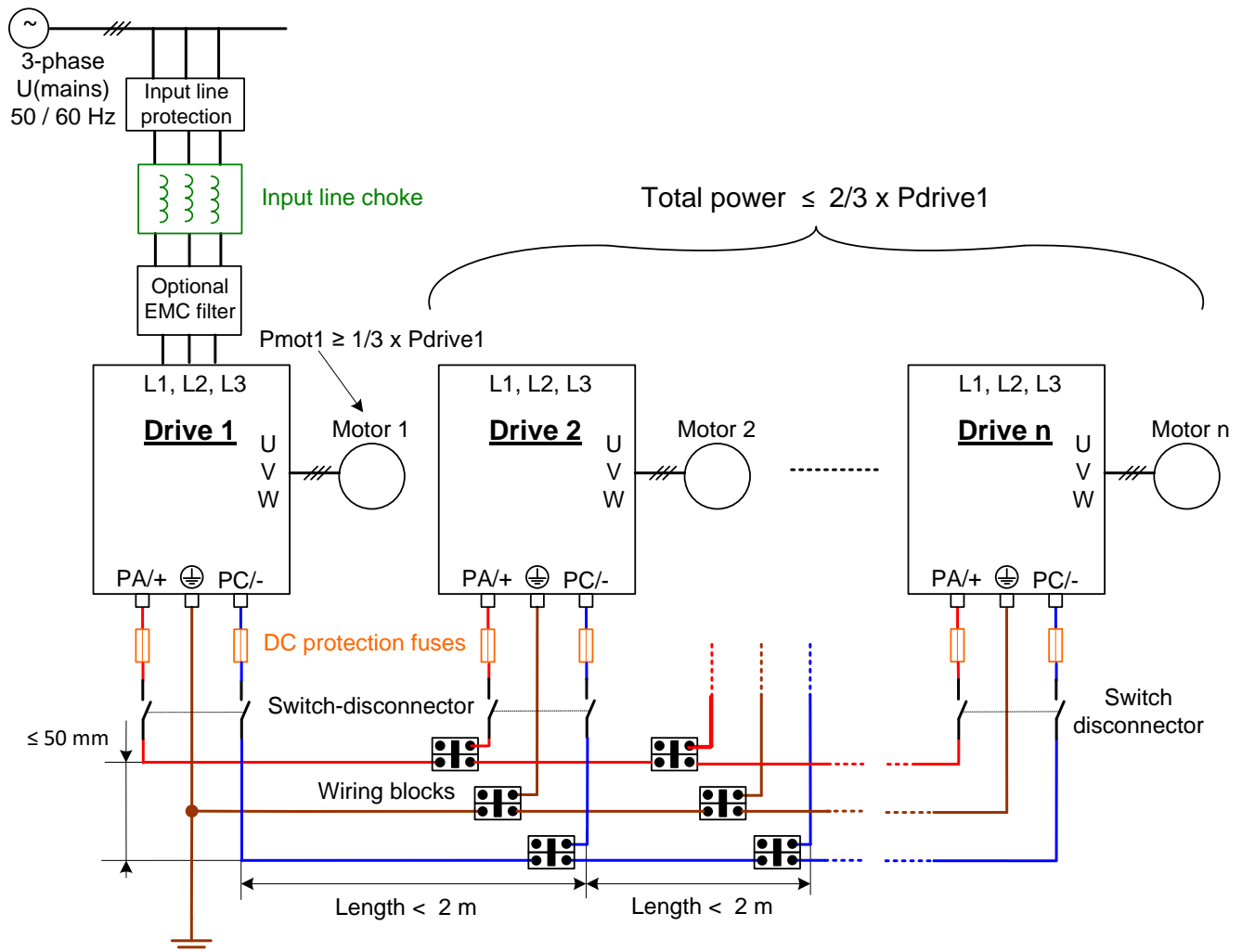

For $U(\text{mains}) = 400 / 480 \text{ V}$, drives 1 ... n must belong to groups A1 or A2

For $U(\text{mains}) = 200 / 240 \text{ V}$, drives 1 ... n must belong to groups B1 or B2

In addition to the general instructions listed at the beginning of this document, the following rules must be respected:

- The power rating of **drive 1 is always the highest power rating of the full system**. It must be used at least at one third of its rated power (for example a 90 kW drive must be used at least with a 30 kW motor, which leaves 60 kW to supply drives 2 to n)
- **An additional input line choke** selected from the list of the section “Line chokes” at the end of this document, **is needed only if** the total power of drives 2 to n is greater than 25 % of the rated power of drive 1, because of the increase of the total DC capacitor value.
- Drives 2 to n are sorted by power rating: from the highest for drive 2 to the lowest for drive n, to get the highest wiring impedance on the lowest drive power rating.
- If drives 2 to drives n belong to groups A1 or B1, the internal soft-charge circuits of these drives will limit the capacitor charge current during switch-on of drive 1.
Drives 2 to n belonging to **group A2 or B2, must use the additional external soft-charge circuit** as described in the section at the end of this document, because there is no DC capacitors charge limitation when they are supplied by the DC bus.
- DC fuses on each drive (drive 1 to drive n) have to be defined according to the “Fuses table” section at the end of this document.

Drive supplied by a DC power supply

The DC power supply replaces the drive which shared a part of its power with the common DC bus in the configuration of the previous section. The output power rating of the DC source must be greater or equal to the sum of all drives' power rating linked on the common DC bus. It has also to provide the transient overload required by the drives in the application.

The DC source output protection fuses have to be selected according to the DC source user's manual. If these data are not provided, the same semiconductors protection class fuses defined for the drive of the same power rating can be used.

The DC source must guarantee a maximum of 3% DC voltage drop and 5% DC voltage ripple at rated load.

If the DC source is a simple diodes or non-reversible SCR/diodes rectifier, input line chokes or DC output choke might have to be added to reduce the input line RMS current.

If the DC source is an active front-end which performs also input harmonic current mitigation with or without regenerative braking capabilities, no additional parts are needed except those needed by the active DC source itself.

In addition to the generic instructions defined at the beginning of this document, the following additional requirements must be applied in this case:

- Drives 2 to n are sorted by power rating: from the highest for drive 2 to the lowest for drive n, to get the highest wiring impedance on the lowest drive power rating.
- If drives 2 to drives n belong to groups A1 or B1, the internal soft-charge circuits of these drives will limit the capacitor charge current during switch-on of drive 1.
Drives 2 to n belonging to group A2 or B2, must use the additional external soft-charge circuit as described in the section at the end of this document, because there is no DC capacitors charge limitation when they are supplied by the DC bus.
- DC fuses on each drive (drive 1 to drive n) have to be defined according to the “Fuses table” section at the end of this document.

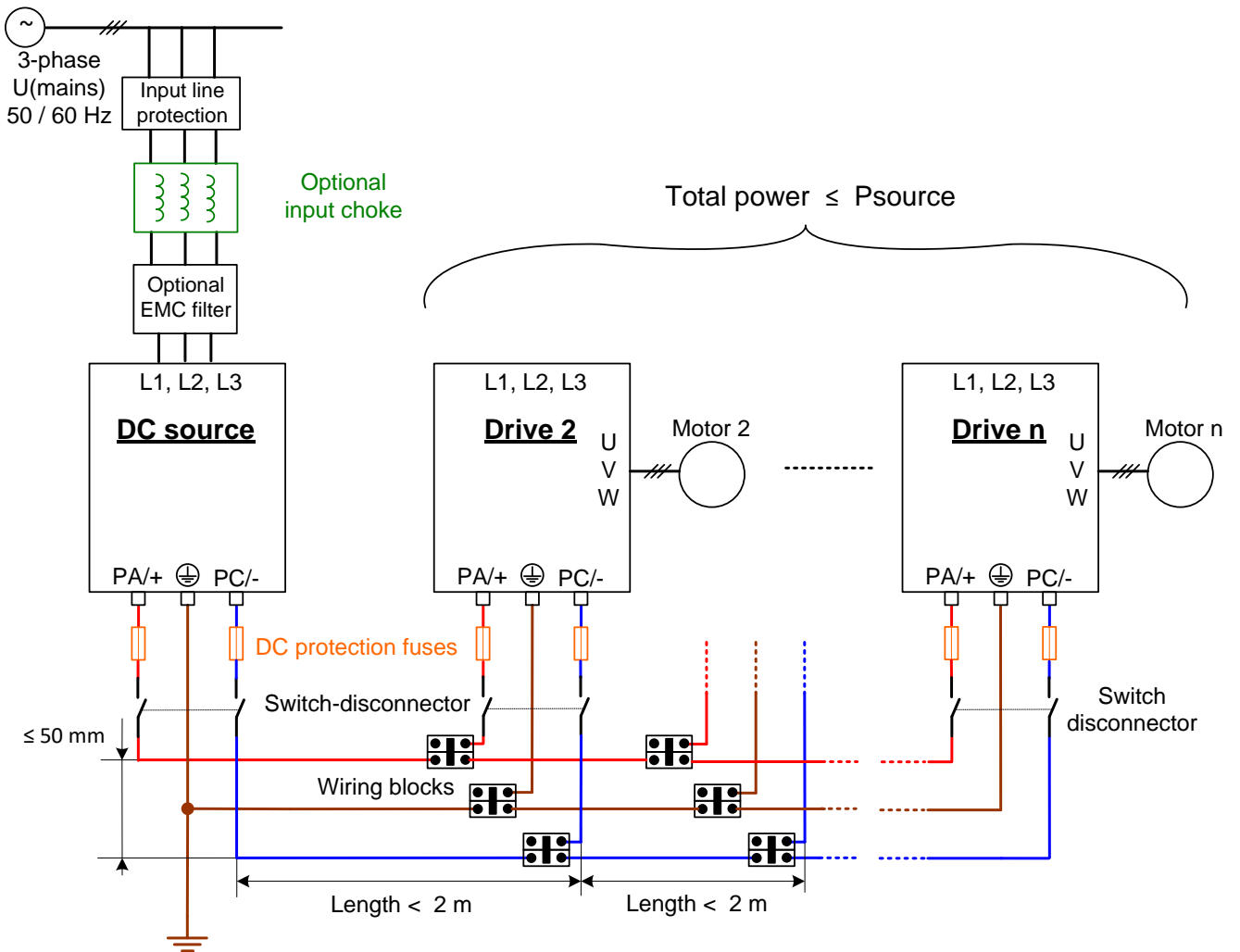

For U(mains) = 400 / 480 V, drives 2 ... n must belong to groups A1 or A2

For U(mains) = 200 / 240 V, drives 2 ... n must belong to groups B1 or B2

Using a braking unit on a common DC bus.

When some drives sharing a common DC-bus are braking and if the other drives linked on the same DC-bus are not able to use all this braking energy, the drives' DC bus capacitors will store this energy. This will lead to an increase of the DC bus voltage. To avoid any over-braking error on the drives (error code: ObF) a braking unit can be used. The same solutions as for a single drive can be used:

- braking resistor,
- or regenerative braking unit.

The full knowledge of the application cycles, or the situations which can happen during all drives' operations is necessary to define what are the peak and average power, the braking time and the duty cycle.

Braking resistor.

In any of the above described DC-bus sharing configuration, a braking resistor can be used on each drive linked to the DC-bus, when this feature is included. The braking IGBT integrated in the drives is activated when the DC bus voltage reaches a defined level. Since the DC-bus voltage is common, any braking IGBT of any drive on the DC-bus will operate to discharge the DC-bus through the externally connected resistor.

On each drive equipped with a braking resistor, the **parameter "brC" must be set to "yes"** to enable operation of the braking IGBT. This will set parameter "brA" to "no" on these drives.

Parameter "brA" can be set in different ways on the other drives sharing the common DC-bus:

- "brA" set to "no" to get the braking performances on drives to follow the deceleration ramp.
- "brA" set to "yes" for drives for which it is not necessary to follow the deceleration ramp.

The calculation of the braking resistor is made in the same way as for a single drive, but the total braking power on the DC bus must be considered. This includes the maximum steady state braking power and the deceleration power of all the drive which have the "brA" parameter set to "no".

This will give the peak power P_{peak} , the total braking time, the average power P_{avg} and the duty cycle.

Using only one braking resistor

The simplest solution is to use only one braking resistor wired on one of the drives sharing the DC bus. This is possible if the calculated peak braking power P_{peak} and the average braking power P_{avg} are lower than the capabilities of one of the drives sharing the DC bus. The decision process is the following:

1. Select the drive to be equipped by a braking resistor

The peak braking power P_{peak} of the system must be dissipated in the braking resistor. To do it, the maximum resistor value R_{max} is calculated by

$$R_{max} = \frac{(U_{brake})^2}{P_{peak}}$$

where U_{brake} is the DC bus voltage when the braking IGBT is in use. On ATV900, $U_{brake} = 780 V$.

The drive selected must accept a minimum braking resistor value R_{min} lower than R_{max} in order to be able to select a resistor value R defined by

$$R_{min} \leq R \leq R_{max}$$

The highest power rating drive sharing the DC bus equipped with a braking IGBT can be used to drive the braking resistor even if it is not this drive which will brake during the application cycle. Even in "ready" state, ATV900 can activate the braking IGBT if the "brC" parameter is set to "yes" and the "brA" parameter set to "no".

If no drive on the DC bus has R_{min} specification verifying $R_{min} \leq R_{max}$, it is not possible to use only one braking resistor in the system.

In this case the section “Using more than one braking resistor” later in this document must be considered.

2. Define the braking resistor rated power

The braking torque characteristic and the duty cycle of the application allow to calculate the average braking power P_{avg} . The rated power of the braking resistor R must be greater or equal to this average braking power. The overload factor of the braking resistor must allow to withstand the peak power P_{peak} . The typical braking cycles defined in the ATV900 catalog can help to select a braking resistor.

Using more than one braking resistor

If there is no drive sharing the DC bus having a R_{min} specification which meet the condition $R_{min} \leq R_{max}$, it means that the peak braking power has to be shared by two or more drives depending on the application.

1. Define number and values of braking resistors

The simplest way is to start with the highest power rating drive sharing the DC bus and to define the peak power $P_{peak(R1)}$ that it will be able to dissipate:

$$P_{peak(R1)} = \frac{(U_{brake})^2}{R_1}$$

with $R_1 \geq R_{min(1)}$ where $R_{min(1)}$ is the minimum braking resistor of drive 1.

This has to be continued with the next highest drives' power ratings to define $R_2 \geq R_{min(2)}$, ... $R_n \geq R_{min(n)}$

with $R_2 \geq R_{min(2)}$ where $R_{min(2)}$ is the minimum braking resistor of drive 2, ...

and $R_n \geq R_{min(n)}$ where $R_{min(n)}$ is the minimum braking resistor of drive n

and to calculate

$$P_{peak(R2)} = \frac{(U_{brake})^2}{R_2}, \dots, P_{peak(Rn)} = \frac{(U_{brake})^2}{R_n}$$

until we get

$$P_{peak(R1)} + P_{peak(R2)} + \dots + P_{peak(Rn)} \geq P_{peak}$$

2. Define braking resistors rated power

The braking torque characteristic and the duty cycle of the application allow to calculate the total average braking power P_{avg} , which must be shared between all the braking resistors. The rated power of each resistor $P_{avg(Ri)}$ will be defined with the same ratio to the average braking power as the ratio of the peak power of each resistor to the total peak power.

The peak power of resistor i is

$$P_{peak(Ri)} = \frac{(U_{brake})^2}{R_i}$$

The total peak power for all the resistors is

$$P_{peak} = P_{peak(R1)} + P_{peak(R2)} + \dots + P_{peak(Rn)} = (U_{brake})^2 \cdot \left(\frac{1}{R_1} + \frac{1}{R_2} + \dots + \frac{1}{R_n} \right)$$

The ratio $k(R_i)$ of the peak power of resistor i to the total peak power is

$$k(R_i) = \frac{P_{peak(Ri)}}{P_{peak}} = \frac{\frac{1}{R_i}}{\frac{1}{R_1} + \frac{1}{R_2} + \dots + \frac{1}{R_n}}$$

The average power of resistor i can be calculated by

$$P_{avg(Ri)} = k(R_i) \cdot P_{avg}$$

Example 1: one braking resistor

Let consider the following system of 3 drives sharing the same DC bus:

ATV9x0D15N4 + ATV9x0U75N4 + ATV9x0U40N4

The application is defined by the following

- ATV9x0D15N4 never brakes; it can be running or in "ready" state
- ATV9x0U75N4 and ATV9x0U40N4 are making cycles and can brake both at rated torque at the same time to decelerate their loads from rated speed down to 0 during 3 s every 40 s.

When ATV9x0D15N4 is operating at least at 80% of its rated torque the braking energy of the two other drives is reused by ATV9x0D15N4.

When ATV9x0D15N4 is in "ready", the braking energy of ATV9x0U75N4 and ATV9x0U40N4 must be dissipated in a braking resistor.

To simplify the calculation, we consider 0.9 as the motors efficiency and 0.95 as the drives efficiency. The total peak power of the system is the sum of the peak power of both drives:

$$P_{peak} = (7.5 \times 0.9 \times 0.95) + (4.0 \times 0.9 \times 0.95) = 6.41 + 3.42 = 9.83 \text{ kW}$$

The maximum resistor R_{max} to get this peak power is

$$R_{max} = \frac{780^2}{9.83 \times 10^3} = 61.9 \Omega$$

The minimum braking resistor value of ATV900HD15N4 is given in ATV900 installation manual

$$R_{min} = 16 \Omega$$

The condition $R_{min} \leq R_{max}$ is met. It is possible to select a resistor value between 16 Ω and 61.9 Ω

The two drives are braking by doing a deceleration at constant torque, it means that the power is decreasing linearly with speed during 3 s and then there is no braking power during 40 s. The average power during one cycle can be calculated by

$$P_{avg} = \frac{1}{3 + 40} \times \left(\frac{9.83 \text{ kW}}{2} \times 3 + 0 \times 40 \right) = 228.7 \text{ W}$$

The reference VW3A7732, 28 Ω , 300 W wired on the ATV9x0D15N4 meets the requirements of this application.

Example 2: two braking resistors

Let consider the following system of 7 drives sharing the same DC bus:

ATV9x0U75N4 + ATV9x0U55N4 + 5 x ATV9x0U22N4

The application is defined by the following

- All drives are making acceleration and deceleration cycles.
- The sequences of the drives are synchronized in a way that there are always drives running using enough power when another one is braking. In this case the DC bus sharing is operating.
- Every 75 s all the drives have to stop at the same time, with a braking torque equal to 1.3 times the rated torque of the motor, during 2s to decrease the speed from rates speed down to 0.

The DC bus sharing does not work to achieve the full braking sequence every 75 s. This braking energy has to be dissipated in braking resistors. Instead of using one braking resistor per drive, it is possible to use less than 7 pieces in this application.

To simplify the calculation, we consider 0.9 as the motors efficiency and 0.95 as the drives efficiency. The total peak power of the system is the sum of the peak power of all drives:

$$P_{peak} = (1.3 \times 7.5 \times 0.9 \times 0.95) + (1.3 \times 5.5 \times 0.9 \times 0.95) + 5 \times (1.3 \times 2.2 \times 0.9 \times 0.95) = 26.7 \text{ kW}$$

$$P_{avg} = \frac{1}{2 + 75} \times \left(\frac{26.7 \text{ kW}}{2} \times 2 + 0 \times 75 \right) = 346.8 \text{ W}$$

The highest drive power rating is ATV9x0U75N4. The minimum braking resistor value is $R_{\min(1)} = 28 \Omega$.

This value exists in the ATV900 catalog, $R_1 = 28 \Omega$ can be selected.

With this value $P_{peak(R1)} = \frac{780^2}{28} = 21.7 \text{ kW}$ which is not enough compared to 26.7 kW

The next highest drive power rating is ATV9x0U55N4. The minimum braking resistor value is $R_{\min(2)} = 31 \Omega$.

This value does not exist in the ATV900 catalog, the next higher value is $R_2 = 60 \Omega$

With this value $P_{peak(R2)} = \frac{780^2}{60} = 10.1 \text{ kW}$.

Now $P_{peak(R1)} + P_{peak(R2)} = 21.7 + 10.1 = 31.8 \text{ kW}$ is greater than 26.7 kW

The application will use

- $R_1 = 28 \Omega$ braking resistor associated with the ATV9x0U75N4
- $R_2 = 60 \Omega$ braking resistor associated with the ATV0x0U55N4

The total average power of the application is shared between R1 and R2 by the following factors:

$$k(R_1) = \frac{\frac{1}{28}}{\frac{1}{28} + \frac{1}{60}} = 0.68 \Rightarrow P_{avg(R1)} = 0.682 \cdot 346.8 = 236.4 \text{ W}$$

$$k(R_2) = \frac{\frac{1}{60}}{\frac{1}{28} + \frac{1}{60}} = 0.32 \Rightarrow P_{avg(R2)} = 0.318 \cdot 346.8 = 110.3 \text{ W}$$

The selected resistance from the catalog are:

VW3A7732, 28 Ω , 300 W

VW3A7731, 60 Ω , 160 W

Regenerative braking unit.

In any of the above described DC-bus sharing configuration using 400 / 480 V drives, the regenerative units ATVRU75N4 and/or ATVRD15N4 can be used on the DC-bus. These regenerative braking units are autonomous devices, that compare the input mains voltage level with the DC-bus voltage, and start to push-back power to the mains when the difference is greater than a fixed threshold.

The rated power of ATVRU75N4 is 6.8 kW continuous, with 10.2 kW transient overload during 60s.

The rated power of ATVRD15N4 is 13.5 kW continuous, with 20.3 kW transient overload during 60s.

These units can be associated in parallel, up to 3 units of any of the two power ratings, to cover up to 45 kW.

When the average braking power is high, these units have an advantage compared to braking resistors:

- regen units can be integrated in the cabinet because the size is smaller than hoisting type resistors,
- the heat dissipation is very low, because their efficiency is better than 95%,
- depending on the braking power and the cycle, the return on investment by energy saving can be fast.

If we consider the same system as in example 2 in previous section, but with a more severe cycle: the machine has to stop every 20 s. In this case the peak power is the same as in the previous cycle, but the average power becomes:

$$P_{avg} = \frac{1}{2 + 20} \times \left(\frac{26.7 \text{ kW}}{2} \times 2 + 0 \times 20 \right) = 1213.6 \text{ W}$$

This leads to select braking resistors of same value but with higher average power:

VW3A7742, 28 Ω , 1100 W 570 mm x 190 mm x 180 mm

VW3A7741, 60 Ω , 500 W 465 mm x 175 mm x 100 mm

To compare with power regenerative units, the peak power of 26.7 kW is achieved by using

1x ATVRD15N4 399 mm x 235 mm x 105 mm

+ 1x ATVRU75N4 337 mm x 175 mm x 80 mm

The two units are wired in parallel, which gives a total of 30.5 kW transient power, more than enough average power, with smaller overall dimensions.

Taking into account a global efficiency of the two regen units of 95% and assuming 8 hours per days, 220 days per year of the system operation, the total energy saved per year is:

$$E_{\text{saved}} = 1213.6 \times 0.95 \times 8 \times 220 = 2029.3 \text{ kWh}$$

Depending on the local energy cost and the buying price difference between the two resistors and the two regen units it is easy to calculate the return on investment of the regen solution.

Fuses table

The fuses to be used with the drives sharing a common DC bus must be selected in the **semiconductors protection class**. The following table give for each drive the rating of the fuse as it is given in the fuses' suppliers catalog. It takes in to account the following parameters:

- The current rating of the fuse is given at 30°C, the value listed in this table takes into account the derating to be applied on the fuse to operate in the 50°C drive's environment,
- The current rating of the fuse takes also into account the drives overload (1.5 rated current during 60s) and the thermal cycling when the drive is running or stopped.

To protect the input rectifiers of the drives two fuses must be used: one fuse on the +DC line and one fuse on the -DC line.

IEC fuses table

Drives 400 / 480 V		Semi-conductor protection class fuses ratings of MERSEN			
reference	Power (kW)	Current rating (A)	IEC DC voltage (V)	Reference	Fuse support for 2 fuses in DC lines
ATV9x0U07N4x	0.75	6	700 ⁽¹⁾	FR10GR69V6	2x US101IHEL
ATV9x0U15N4x	1.5	8	700 ⁽¹⁾	FR10GR69V8	2x US101IHEL
ATV9x0U22N4x	2.2	12.5	700 ⁽¹⁾	FR10GR69V12.5	2x US101IHEL
ATV9x0U30N4x	3.0	16	700 ⁽¹⁾	FR10GR69V16	2x US101IHEL
ATV9x0U40N4x	4.0	20	700 ⁽¹⁾	FR10GR69V20	2x US101IHEL
ATV9x0U55N4x	5.5	25	700 ⁽¹⁾	FR10GR69V25	2x US101IHEL
ATV9x0U75N4x	7.5	32	700 ⁽¹⁾	FR10GR69V32	2x US101IHEL
ATV9x0D11N4x	11	50	1000	FR27GB80V50T	PS272PREBS
ATV9x0D15N4x	15	63	1000	FR27GB80V63T	PS272PREBS
ATV9x0D18N4x	18.5	63	1000	FR27GB80V63T	PS272PREBS
ATV9x0D22N4x	22	80	1000	FR27GB80V80T	PS272PREBS
ATV9x0D30N4x	30	100	1000	FR27GB80V100T	PS272PREBS
ATV9x0D37N4x	37	125	750 ⁽¹⁾	NH1GS69V125PV	2x HPBB11PPR
ATV9x0D45N4x	45	160	750 ⁽¹⁾	NH1GS69V160PV	2x HPBB11PPR
ATV9x0D55N4x	55	200	750 ⁽¹⁾	NH1GS69V200PV	2x HPBB11PPR
ATV9x0D75N4x	75	250	750 ⁽¹⁾	NH1GS69V250PV	2x HPBB11PPR
ATV9x0D90N4x	90	315	750 ⁽¹⁾	NH2GS69V315PV	2x HPBB21PPR
ATV9x0C11N4x	110	400	700 ⁽¹⁾	PC32UD69V400A	2x SIDN80630A
ATV9x0C13N4x	132	450	700 ⁽¹⁾	PC32UD69V450A	2x SIDN80630A
ATV9x0C16N4x	160	500	700 ⁽¹⁾	PC32UD69V500A	2x SIDN80630A
ATV9x0C22N4x	220	(3)	(3)	(3)	(3)
ATV9x0C25N4x	250	(3)	(3)	(3)	(3)
ATV9x0C31N4x	315	(3)	(3)	(3)	(3)

Drives 200 / 240 V		Semi-conductor protection class fuses ratings of MERSEN			
reference	Power (kW)	Current rating (A)	IEC DC voltage (V)	Reference	Fuse support for 2 fuses in DC lines
ATV9x0U07M3x	0.75	8	700	FR10GR69V8	US102I
ATV9x0U15M3x	1.5	16	700	FR10GR69V16	US102I
ATV9x0U22M3x	2.2	20	700	FR10GR69V20	US102I
ATV9x0U30M3x	3.0	25	700	FR10GR69V25	US102I
ATV9x0U40M3x	4.0	40	900	FR14GR69V40	US142I
ATV9x0U55M3x	5.5	50	900	FR14GR69V50	US142I
ATV9x0U75M3x	7.5	63	900	FR22GR69V63	US222I
ATV9x0D11M3x	11	80	900	FR22GR69V80	US222I
ATV9x0D15M3x	15	100	900	FR22GR69V100	US222I
ATV9x0D18M3x	18.5	125	750	NH00GS69V125PV	BB002EPBR
ATV9x0D22M3x	22	160	750	NH1GS69V160PV	BB12PPR
ATV9x0D30M3x	30	200	750	NH1GS69V200PV	BB12PPR
ATV9x0D37M3x	37	250	750	NH1GS69V250PV	BB12PPR
ATV9x0D45M3x	45	315	750	NH2GS69V315PV	BB22PPR
ATV9x0D55M3x	55	400	750	NH2UD69V400PV	BB22PPR
ATV9x0D75M3x	75	500	750	NH2UD69V500PV	BB22PPR

UL fuses table

Drives 400 / 480 V		Semi-conductor protection class fuses ratings of MERSEN			
reference	Power (kW)	Current rating (A)	UL DC voltage (V)	Reference	Fuse support for 2 fuses in DC lines
ATV9x0U07N4x	0.75	6	1000	DCT6-2	2x US101IHEL
ATV9x0U15N4x	1.5	8	1000	DCT8-2	2x US101IHEL
ATV9x0U22N4x	2.2	12	1000	DCT12-2	2x US101IHEL
ATV9x0U30N4x	3.0	15	1000	DCT15-2	2x US101IHEL
ATV9x0U40N4x	4.0	20	1000	DCT20-2	2x US101IHEL
ATV9x0U55N4x	5.5	25	1000	DCT25-2	2x US101IHEL
ATV9x0U75N4x	7.5	30	1000	DCT30-2	2x US101IHEL
ATV9x0D11N4x	11	50	950 ⁽¹⁾	HSJ50	PS272PREBS
ATV9x0D15N4x	15	60	950 ⁽¹⁾	HSJ60	PS272PREBS
ATV9x0D18N4x	18.5	60	950 ⁽¹⁾	HSJ60	PS272PREBS
ATV9x0D22N4x	22	110	950 ⁽¹⁾	HSJ110 ⁽²⁾	2x 62001HPJ
ATV9x0D30N4x	30	110	950 ⁽¹⁾	HSJ110 ⁽²⁾	2x 62001HPJ
ATV9x0D37N4x	37	125	950 ⁽¹⁾	HSJ125	2x 62001HPJ
ATV9x0D45N4x	45	150	950 ⁽¹⁾	HSJ150	2x 62001HPJ
ATV9x0D55N4x	45	200	950 ⁽¹⁾	HSJ200	2x 62001HPJ
ATV9x0D75N4x	55	250	950 ⁽¹⁾	HSJ250	2x 64031HPJ
ATV9x0D90N4x	75	350	950 ⁽¹⁾	HSJ350	2x 64031HPJ
ATV9x0C11N4x	110	400	950 ⁽¹⁾	HSJ400	2x 64031HPJ
ATV9x0C13N4x	132	450	950 ⁽¹⁾	HSJ450	2x 6631HPJ
ATV9x0C16N4x	160	500	950 ⁽¹⁾	HSJ500	2x 6631HPJ
ATV9x0C22N4x	220	(3)	(3)	(3)	(3)
ATV9x0C25N4x	250	(3)	(3)	(3)	(3)
ATV9x0C31N4x	315	(3)	(3)	(3)	(3)

Drives 200 / 240 V		Semi-conductor protection class fuses ratings of MERSEN			
reference	Power (kW)	Current rating (A)	IEC DC voltage (V)	Reference	Fuse support for 2 fuses in DC lines
ATV9x0U07M3x	0.75	8	500	FR10GR69V8	US102I
ATV9x0U15M3x	1.5	16	500	FR10GR69V16	US102I
ATV9x0U22M3x	2.2	20	500	FR10GR69V20	US102I
ATV9x0U30M3x	3.0	25	500	FR10GR69V25	US102I
ATV9x0U40M3x	4.0	40	500	FR14GR69V40	US142I
ATV9x0U55M3x	5.5	50	500	FR14GR69V50	US142I
ATV9x0U75M3x	7.5	63	500	FR22GR69V63	US222I
ATV9x0D11M3x	11	80	500	FR22GR69V80	US222I
ATV9x0D15M3	15	100	500	FR22GR69V100	US222I
ATV9x0D18M3x	18.5	125	500	HSJ125	2x 62001HPJ
ATV9x0D22M3x	22	160	750	HSJ150	2x 62001HPJ
ATV9x0D30M3x	30	200	750	HSJ200	2x 62001HPJ
ATV9x0D37M3x	37	250	750	HSJ250	2x 64031HPJ
ATV9x0D45M3x	45	315	750	HSJ350	2x 64031HPJ
ATV9x0D55M3x	55	400	750	HSJ400	2x 64031HPJ
ATV9x0D75M3x	75	500	750	HSJ500	2x 6631HPJ

- (1) with two fuses: one in +DC and one in –DC
- (2) fuse holder for fuses ratings HSJ80 and HSJ100 is not UL certified up to 600 V, therefore, rating 110 A is used.
- (3) waiting for MERSEN proposal

DC switch-disconnector.

To disconnect one drive from the DC bus while other drives remain in operation, each drive can be equipped by a DC switch-disconnector selected in the following table. It takes into account:

- the derating to apply to these devices to operate at 50°C ambient temperature,
- the operation overload on the drives.

These devices use 2x 2 poles in series and must be installed as described in the devices instruction sheet for use at 800 V DC voltage.

Drives 380 / 480 V		DC switch-disconnector			
reference	Power (kW)	Short name	Reference	DC voltage @50°C (V)	Rated current @50°C (A)
ATV9x0U07N4x	0.75	C60NA-DC	A9N61690	800	30
ATV9x0U15N4x	1.5				
ATV9x0U22N4x	2.2				
ATV9x0U30N4x	3.0				
ATV9x0U40N4x	4.0				
ATV9x0U55N4x	5.5				
ATV9x0U75N4x	7.5				
ATV9x0D11N4x	11				
ATV9x0D15N4x	15				
ATV9x0D18N4x	18.5	C120NA-DC	A9N61701	1000	96
ATV9x0D22N4x	22				
ATV9x0D30N4x	30				
ATV9x0D37N4x	37				
ATV9x0D45N4x	45				
ATV9x0D55N4x	55	NSX160 NA DC PV 4P	LV438160	1000	160
ATV9x0D75N4x	75				
ATV9x0D90N4x	90	NSX200 NA DC PV 4P	LV438250	1000	190
ATV9x0C11N4x	110	NSX400 NA DC PV 4P	LV438300	1000	400
ATV9x0C13N4x	132				
ATV9x0C16N4x	160				
ATV9x0C22N4x	220	NSX500 NA DC PV 4P	LV438500	1000	490
ATV9x0C25N4x	250	NSX630b NA DC PV 4P		1000	630
ATV9x0C31N4x	315	NSX800 NA DC PV 4P		1000	800

Drives 200 / 240 V		DC switch-disconnector			
reference	Power (kW)	Short name	Reference	DC voltage @50°C (V)	Rated current @50°C (A)
ATV9x0U07M3x	0.75	C60NA-DC	A9N61690	800	30
ATV9x0U15M3x	1.5				
ATV9x0U22M3x	2.2				
ATV9x0U30M3x	3.0				
ATV9x0U40M3x	4.0				
ATV9x0U55M3x	5.5				
ATV9x0U75M3x	7.5				
ATV9x0D11M3x	11	C120NA-DC	A9N61701	1000	96
ATV9x0D15M3x	15				
ATV9x0D18M3x	18.5				
ATV9x0D22M3x	22				
ATV9x0D30M3x	30	NSX160 NA DC PV 4P	LV438160	1000	160
ATV9x0D37M3x	37				
ATV9x0D45N4x	45	NSX200 NA DC PV 4P	LV438250	1000	190
ATV9x0D55M3x	55	NSX400 NA DC PV 4P	LV438300	1000	400
ATV9x0D75M3x	75				

Line chokes

Additional line chokes are required in some configuration (see section “Drives fed by DC terminals”).

Drives 400 V / 480 V			External lines chokes		Integrated DC chokes
Power rating kW	Catalog reference	Group	Inductance mH	Reference	Inductance mH
0.75	ATV9x0U07N4(x)	A1	-	-	21.6
1.5	ATV9x0U15N4(x)	A1	10.0	VW3A4551	11.5
2.2	ATV9x0U22N4(x)	A1	4.0	VW3A4552	8.10
3	ATV9x0U30N4(x)	A1	4.0	VW3A4552	5.80
4	ATV9x0U40N4(x)	A1	4.0	VW3A4552	4.55
5.5	ATV9x0U55N4(x)	A1	2.0	VW3A4553	3.40
7.5	ATV9x0U75N4(x)	A1	2.0	VW3A4553	2.90
11	ATV9x0D11N4(x)	A1	1.0	VW3A4554	2.25
15	ATV9x0D15N4(x)	A1	1.0	VW3A4554	1.52
18.5	ATV9x0D18N4(x)	A1	0.50	VW3A4555	1.18
22	ATV9x0D22N4(x)	A1	0.50	VW3A4555	1.00
30	ATV9x0D30N4(x)	A2	0.50	VW3A4555	0.760
37	ATV9x0D37N4(x)	A2	0.30	VW3A4556	0.585
45	ATV9x0D45N4(x)	A2	0.30	VW3A4556	0.490
55	ATV9x0D55N4(x)	A2	0.30	VW3A4556	0.365
75	ATV9x0D75N4(x)	A2	0.30	VW3A4556	0.310
90	ATV9x0D90N4(x)	A2	0.155	VW3A4558	0.226
110	ATV9x0C11N4(x)	A2	0.120	VW3A4559	0.160
132	ATV9x0C13N4(x)	A2	0.098	VW3A4560	0.160
160	ATV9x0C16N4(x)	A2	0.066	VW3A4561	0.160
220	ATV9x0C22N4(x)	A2	0.049	VW3A4562	0.105
250	ATV9x0C25N4(x)	A2	0.049	VW3A4562	0.095
315	ATV9x0C31N4(x)	A2	0.038	VW3A4564	0.069

Drives 200 V / 240 V 3-phase			External lines chokes		Integrated DC chokes
Power rating kW	Catalog reference	Group	Inductance mH	Reference	Inductance mH
0.75	ATV9x0U07M3(x)	A1	-	-	6.45
1.5	ATV9x0U15M3(x)	A1	4.0	VW3A4552	3.5
2.2	ATV9x0U22M3(x)	A1	4.0	VW3A4552	2.55
3	ATV9x0U30M3(x)	A1	2.0	VW3A4553	1.85
4	ATV9x0U40M3(x)	A1	2.0	VW3A4553	1.47
5.5	ATV9x0U55M3(x)	A1	1.0	VW3A4554	1.27
7.5	ATV9x0U75M3(x)	A1	1.0	VW3A4554	1.52
11	ATV9x0D11M3(x)	A1	0.50	VW3A4555	1.0
15	ATV9x0D15M3(x)	A1	0.50	VW3A4555	0.52
18.5	ATV9x0D18M3(x)	A1	0.50	VW3A4555	0.52
22	ATV9x0D22M3(x)	A1	0.30	VW3A4556	0.52
30	ATV9x0D30M3(x)	A2	0.30	VW3A4556	0.265
37	ATV9x0D37M3(x)	A2	0.155	VW3A4558	0.226
45	ATV9x0D45M3(x)	A2	0.155	VW3A4558	0.226
55	ATV9x0D55M3(x)	A2	0.155	VW3A4558	0.160
75	ATV9x0D75M3(x)	A2	0.150	VW3A4557	0.160

External soft-charge circuit for drives of groups x2

The soft-charge circuit of the internal main capacitors is not operating on these drives when they are supplied by the DC terminals. **Drives of group A2 and B2 sharing the DC bus with other drives must always use the additional external soft-charge circuit** described below:

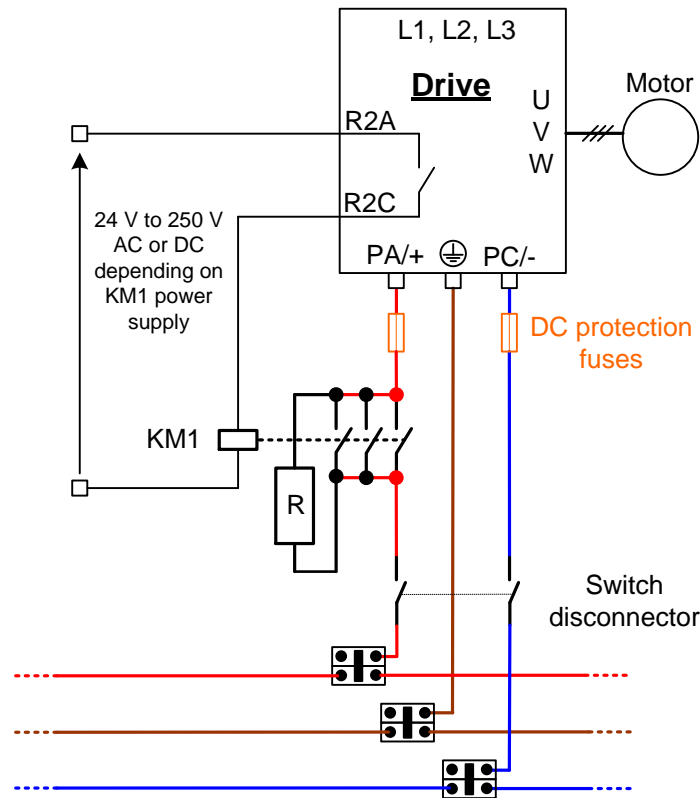

ATV9x0 settings

The drive's internal function to perform the soft-charge function must be used in the following way:

The parameter "dCo" (DC charging assign.) must be configured. The factory setting of this parameter is "no". It must be set to one of the possible options depending on the drive features to drive the contactor KM1:

- "r2...r3" if one of the internal relays is used,
- "r4...r6" if the relay output option module is used,
- "do1...do2" if the I/O extension module is used, in this case verify the maximum voltage and current data of the I/Os and the characteristics of the contactor coil.

The parameter "dCt" (DC bus charge time) must be set to the value listed in the table below.

For more details, see ATV9x0 programming manual in section "DC bus supply".

Contactors KM1

A standard 3-poles AC contactor sized according AC-1 specification can be used. The peak current in the contacts occurs when the contactor is switched on at the end of the charge. The time to charge is defined to be greater than 7 times the time constant, which leads to a remaining voltage difference less than 1 V.

The control voltage of the coil must be within 12Vdc to 48Vdc and up to 250Vac in order to be driven by one of the drives' relay outputs.

The 3 poles are wired in parallel to flow the DC current as shown on the schematics above. In this configuration, the total current is 2.25 times the rated current of the contactor defined for AC-1 coordination.

The length of the wire going through the contactor is integrated in the maximum length between two drives and therefore must be as short as possible. The +DC wire and the –DC wire must be kept parallel as much as possible to get a low leakage inductance in order to avoid overvoltage on the DC bus during operation.

Resistor R

The charge resistor R is selected in the standard braking resistors listed in ATV9x0 catalog. The reference depends on the drive rating as shown in the table below.

There are no constraints on the length of the wires from the resistor's terminals to the contactor (shown in black on the drawing above).

Drive reference 400 / 480 V	Resistor R		ATV9x0 parameter "dCt"	Contactor KM1 according to AC-1 coordination		
	Value (Ω)	Ref.		Value (s)	Ref.	Rated current (A)
ATV9x0D30N4	28	VW3A7732	0.5	LC1D25●●	40	90
ATV9x0D37N4	28	VW3A7732	0.5	LC1D32●●	50	112
ATV9x0D45N4	28	VW3A7732	0.6	LC1D40●●	60	135
ATV9x0D55N4	16	VW3A7733	0.6	LC1D65●●	90	180
ATV9x0D75N4	16	VW3A7733	0.6	LC1D80●●	125	281
ATV9x0D90N4	16	VW3A7733	0.8	LC1D80●●	125	281
ATV9x0C11N4	16	VW3A7733	1.1	LC1D115●●	200	450
ATV9x0C13N4	16	VW3A7733	1.1	LC1D115●●	200	450
ATV9x0C16N4	16	VW3A7733	1.1	LC1D115●●	200	450
ATV9x0C22N4	10	VW3A7734	1.0	LC1F150●●	250	562
ATV9x0C25N4	10	VW3A7734	1.0	LC1F225●●	315	709
ATV9x0C31N4	8	VW3A7735	1.2	LC1F330●●	400	900

Drive reference 200 / 240 V	Resistor R		ATV9x0 parameter "dCt"	Contactor KM1 according to AC-1 coordination		
	Value (Ω)	Ref.		Value (s)	Ref.	Rated current (A)
ATV9x0D15M3	28	VW3A7732	0.8	LC1D25●●	40	90
ATV9x0D18M3	28	VW3A7732	1.0	LC1D32●●	50	112
ATV9x0D22M3	28	VW3A7732	1.2	LC1D40●●	60	135
ATV9x0D30M3	16	VW3A7733	1.3	LC1D65●●	80	180
ATV9x0D37M3	16	VW3A7733	1.3	LC1D80●●	125	281
ATV9x0D45M3	16	VW3A7733	1.5	LC1D80●●	125	281
ATV9x0D55M3	16	VW3A7733	1.1	LC1D115●●	200	450
ATV9x0D75M3	16	VW3A7733	1.1	LC1D115●●	200	450

Switch disconnecter

If a DC switch-disconnector is used, it must be located as shown on the drawing above in order to disconnect the external soft charge circuit from the DC bus when the switch is opened.

Wiring Options

Wiring blocks

Type			
Pass-through 1-pole 1x1 terminal block	NSYTRV102	NSYTRV162	NSYTRV352
Jumper to connect 2 blocks	NSYTRAL102	NSYTRAL162	NSYTRAL352
Rated current at 690 V	54 A	73 A	126 A
Maximum current at 1000 V	76 A	101 A	125 A
Cable cross section capability	0.5 – 16 mm ²	1.5 – 25 mm ²	1.5 – 50 mm ²

