

Introduction



An increasing number of users requires products which carry out several safety functions without needing the complex management of a safety PLC or the complex wiring of many traditional safety modules. Such problems arise mainly when the safety functions are typically greater than 3 or 4, and/or when managing a safety PLC software (software purchase, training courses, programming of all modules, software management and filing, updates etc.) turns out to be too great an overhead in relation to problem complexity.

Pizzato Elettrica introduces Gemnis, a series of electronic modules which are pre-programmed for specific customer applications or for generic safety macro-functions commonly used in industrial contexts. The following pages list some of the pre-programmed products for generic macro-functions commonly used in the industrial sector. These products are also available for individual purchase. Any customer requiring a product pre-programmed to their particular specification can contact the Pizzato Elettrica technical department (minimum volumes are requested).

The resulting advantages for customers typically include simplified product management (purchase of finished components) and reduced general costs (no software to be installed and managed, products are immediately operational).

All Gemnis series products are able to provide circuit solutions at SIL 3 (EN 62061), PL e (EN ISO 13849-1) or category 4 (EN ISO 13849-1) levels.

Quality marks:



EC type examination certificate: M6A 16 06 75157 010
 UL approval: E131787
 CCC approval: 2013010305640211
 TÜV SÜD approval: Z10 16 05 75157 009
 EAC approval: RU C-IT.YT03.B.00035/19

Code structure

CS MF201M0-P●●

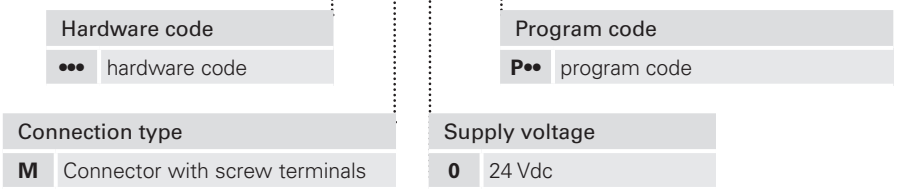

**Product list**

Product code	Functions executed	Safety outputs	Signalling outputs	Page
CS MF201M0-P1	Monitoring of 2 guards in AND and 1 emergency stop with automatic start or manual monitored start.	3 NO	4 PNP	307
CS MF202M0-P2	Monitoring of 4 guards in AND, 1 bypass selector, 1 emergency stop, automatic start or manual monitored start, general enabling signal.	4 PNP	4 PNP	308
CS MF202M0-P3	Monitoring of 6 guards in AND (2NC contacts), 1 emergency stop, automatic start or manual monitored start.	4 PNP	4 PNP	309
CS MF202M0-P4	Monitoring of 6 guards in AND (1NO+1NC contacts), 1 emergency stop, automatic start or manual monitored start.	4 PNP	4 PNP	310
CS MF202M0-P5	Monitoring of 4 guards with independent outputs, 1 bypass selector, 1 emergency stop, automatic start or manual monitored start, general enabling signal.	4 PNP	4 PNP	311
CS MF202M0-P6	Monitoring of 2 guards, 1 bypass selector, 1 emergency stop, automatic start or manual monitored start, general enabling signal. Three instantaneous outputs and one delayed output with selector switch with 4 times. Selectable On/Off delay.	4 PNP	4 PNP	312
CS MF202M0-P7	Monitoring of 4 guards (AND linked) with switches with guard locking, operating principle "D", 1 emergency stop, monitored start. Two instantaneous outputs and two delayed outputs with selector switch with 4 times.	4 PNP	4 PNP	313
CS MF202M0-P8	Monitoring of 4 guards in AND with switches with guard locking, operating principle "E", 1 emergency stop, monitored start. Two instantaneous outputs and two delayed outputs with selector switch with 4 times.	4 PNP	4 PNP	314

Legend

Movable guard monitoring

Start function

Time selector

Monitoring of a movable guard with lock

Bypass selector

Enabling input

Emergency stop



Product code
CS MF201M0-P1

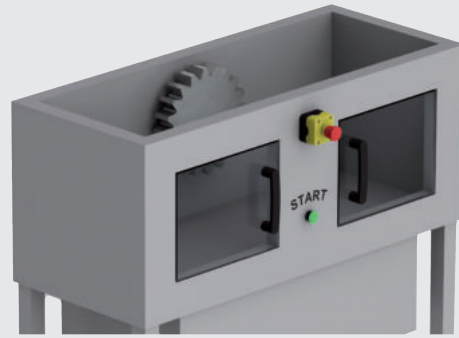

Main functions

- Monitoring of 2 guards
- Monitoring of 1 emergency stop
- Automatic start or monitored manual start

Outputs

- 3 NO safety outputs
- 4 PNP signalling outputs

Technical data: see CS MP201M0
Dimensions, cable cross sections, terminal tightening torque: page 317, design C
Internal block diagram: page 320
Terminal layout: page 320

Application program: P1

The application program stored in the module executes one or more safety functions, as shown in the following block diagram:

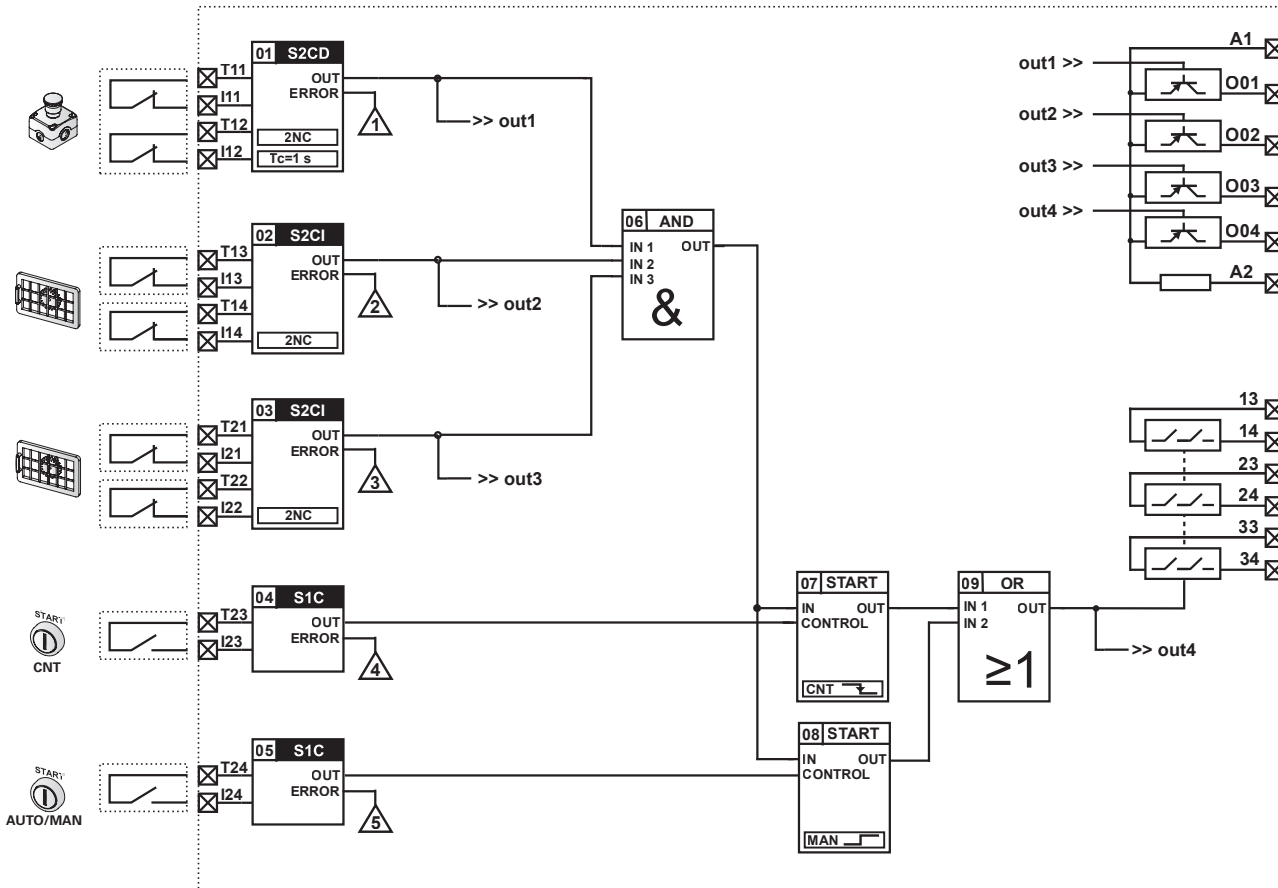



CS MF202M0-P2 pre-programmed module



Product code
CS MF202M0-P2



Main functions

- Monitoring of 4 guards
- 1 bypass selector
- 1 emergency stop
- Automatic start or monitored manual start
- General enabling signal

Outputs

- 4 PNP safety outputs
- 4 PNP signalling outputs

Technical data: see CS MP202M0
 Dimensions, cable cross sections, terminal tightening torque: page 317, design C
 Internal block diagram: page 320
 Terminal layout: page 320

Application program: P2

The application program stored in the module executes one or more safety functions, as shown in the following block diagram:

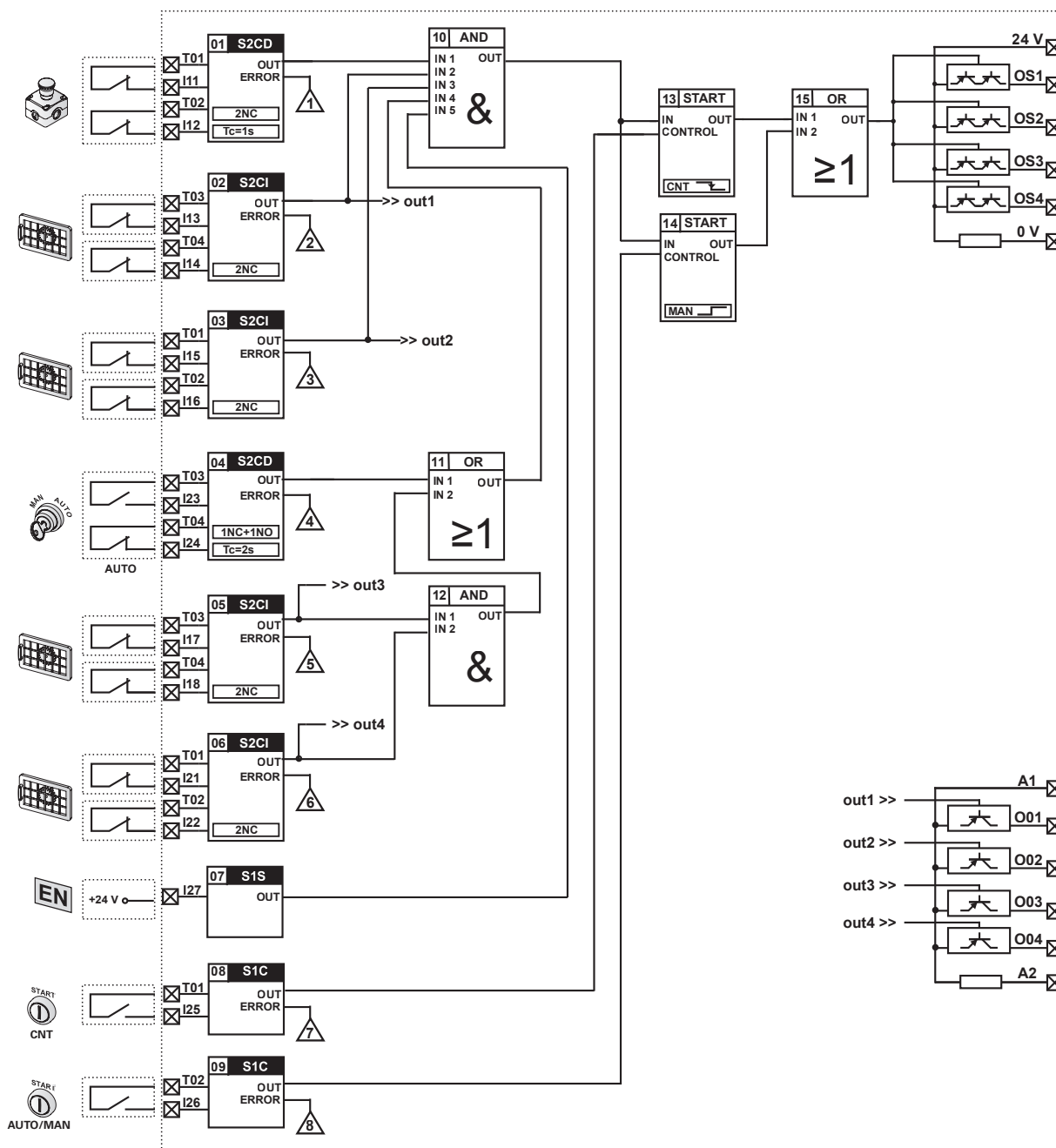



Product code
CS MF202M0-P3

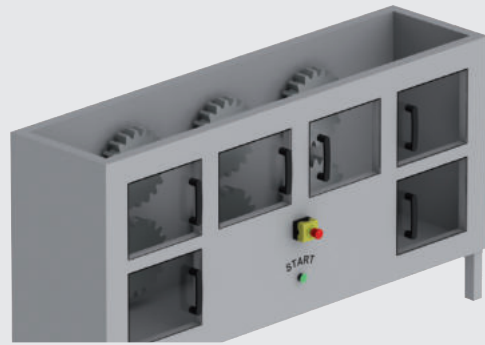

Main functions

- Monitoring of 6 guards (2NC contacts)
- 1 emergency stop
- Automatic start or monitored manual start

Outputs

- 4 PNP safety outputs
- 4 PNP signalling outputs

Technical data: see CS MP202M0

Dimensions, cable cross sections, terminal tightening torque: page 317, design C

Internal block diagram: page 320

Terminal layout: page 320

Application program: P3

The application program stored in the module executes one or more safety functions, as shown in the following block diagram:

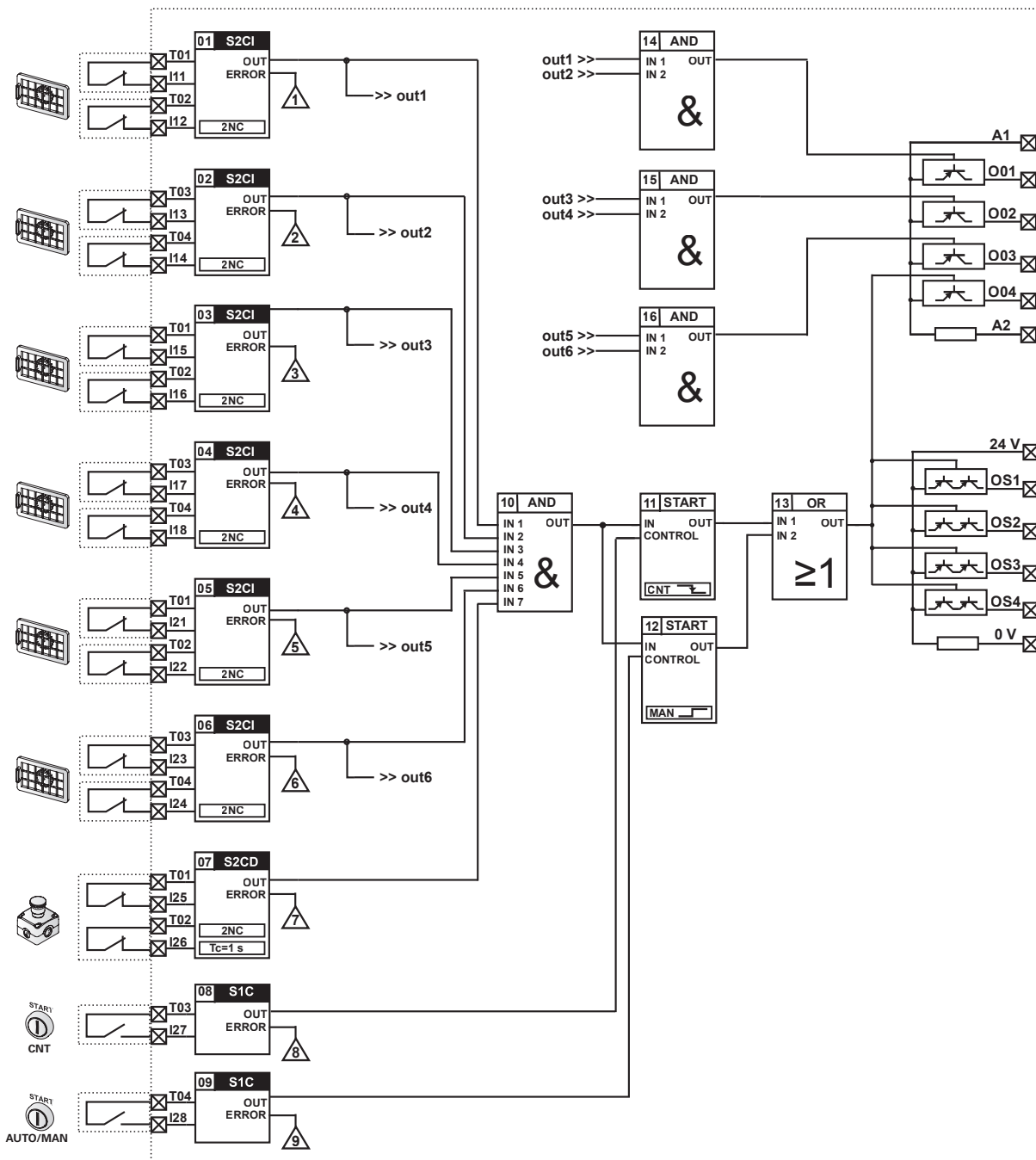



Product code
CS MF202M0-P4

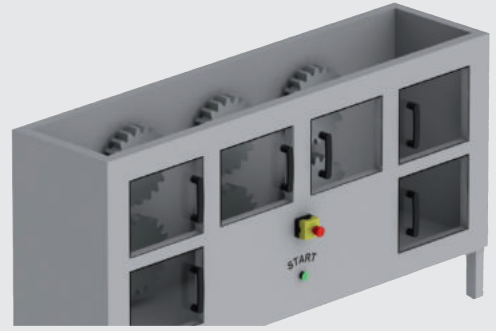

Main functions

- Monitoring of 6 guards (1NC+1NO contacts)
- 1 emergency stop
- Automatic start or monitored manual start

Outputs

- 4 PNP safety outputs
- 4 PNP signalling outputs

Technical data: see CS MP202M0
Dimensions, cable cross sections, terminal tightening torque: page 317, design C
Internal block diagram: page 320
Terminal layout: page 320

Application program: P4

The application program stored in the module executes one or more safety functions, as shown in the following block diagram:

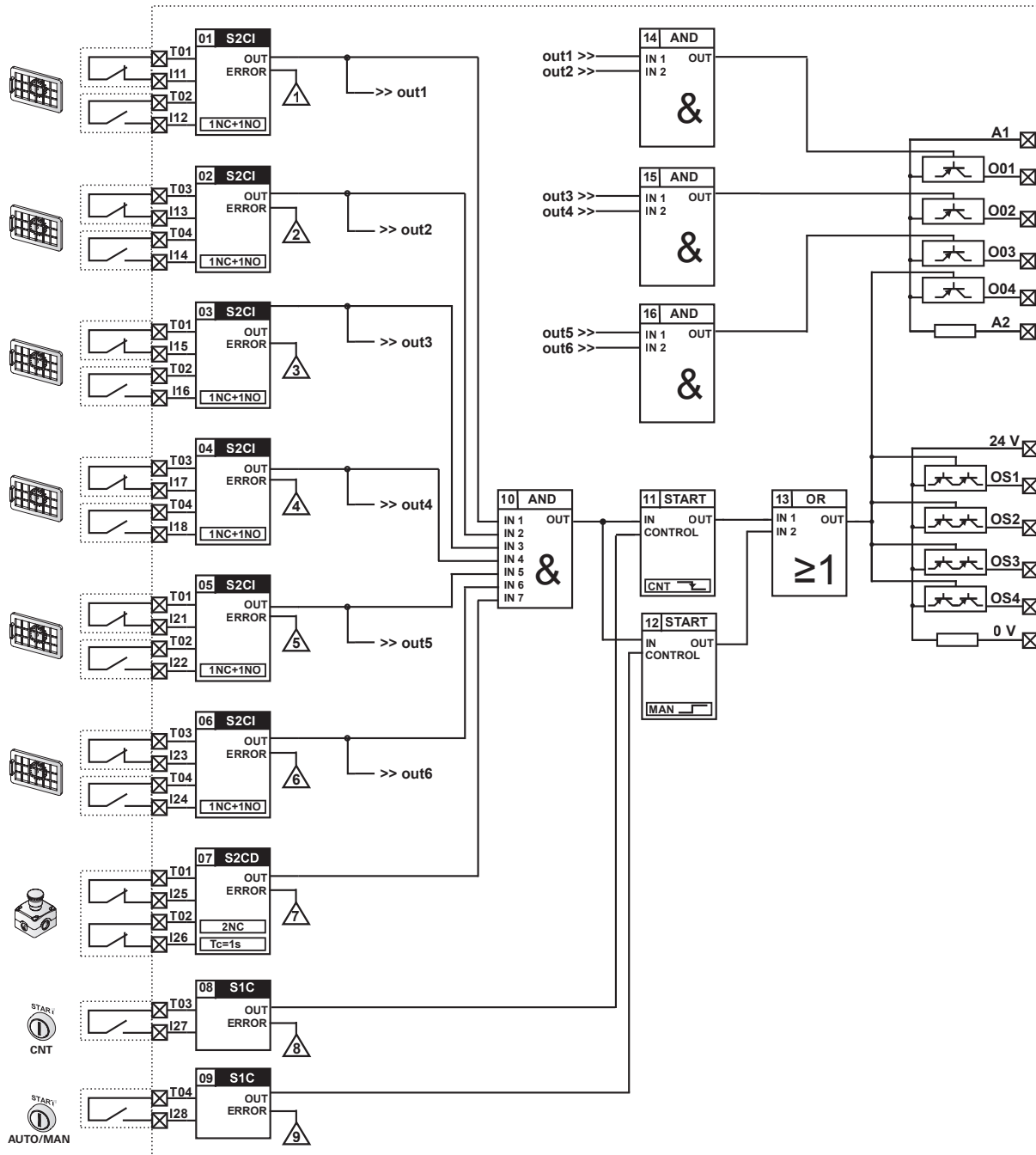



Product code
CS MF202M0-P5



Main functions

- Monitoring of 4 guards with independent outputs
- 1 bypass selector
- 1 emergency stop
- Automatic start or monitored manual start
- General enabling signal

Outputs

- 4 PNP safety outputs
- 4 PNP signalling outputs

Technical data: see CS MP202M0
 Dimensions, cable cross sections, terminal tightening torque: page 317, design C
 Internal block diagram: page 320
 Terminal layout: page 320

Application program: P5

The application program stored in the module executes one or more safety functions, as shown in the following block diagram:

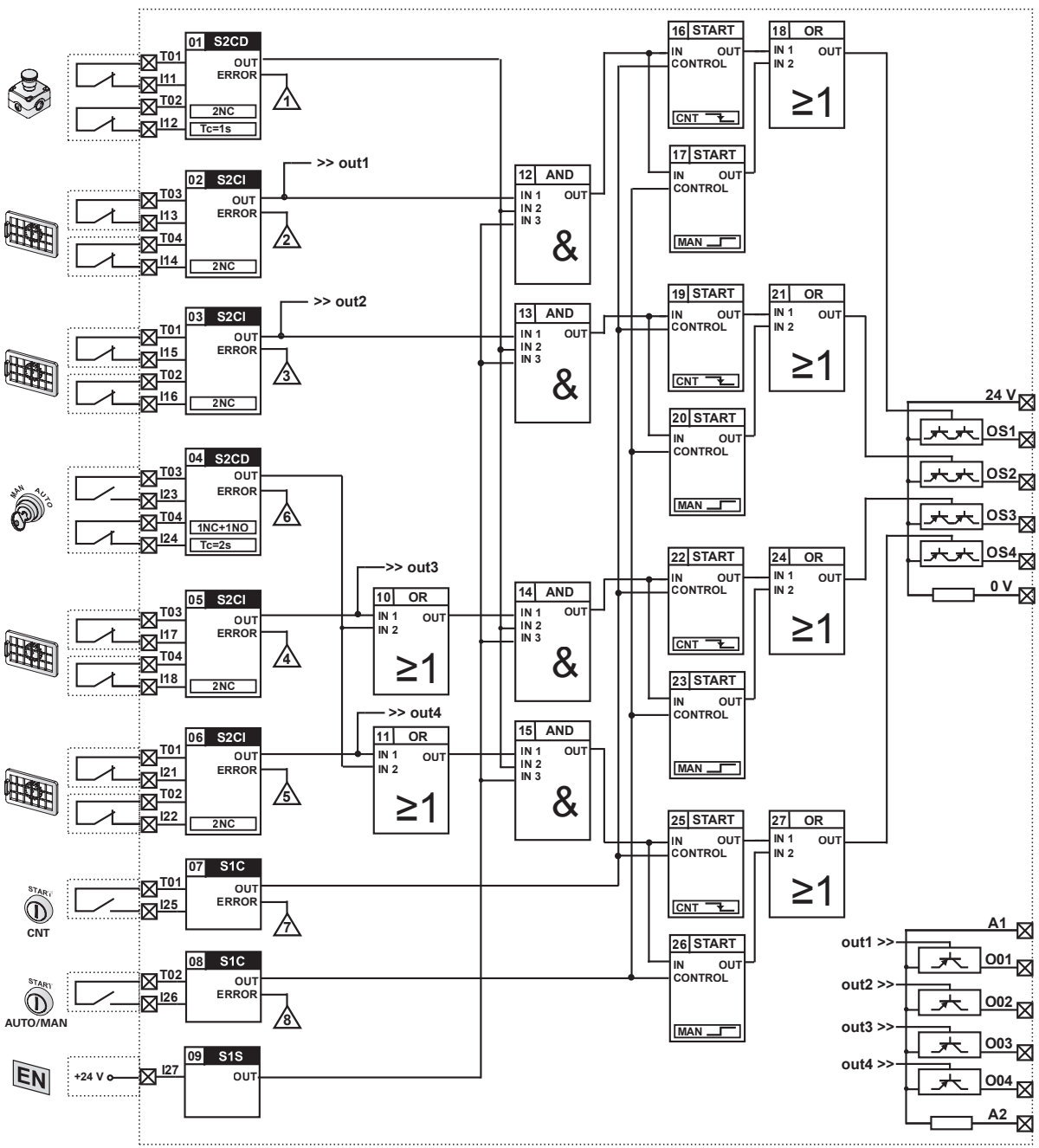



CS MF202M0-P6 pre-programmed module



Product code
CS MF202M0-P6



Main functions

- Monitoring of 2 guards
- 1 bypass
- 1 emergency stop
- Automatic start or monitored manual start
- General enabling signal
- Selectable On/Off delay
- Selector switch with 4 times

Outputs

- Three instantaneous outputs and one delayed PNP safety output
- 4 PNP signalling outputs

Technical data: see CS MP202M0
 Dimensions, cable cross sections, terminal tightening torque: page 317, design C
 Internal block diagram: page 320
 Terminal layout: page 320

Application program: P6

The application program stored in the module executes one or more safety functions, as shown in the following block diagram:

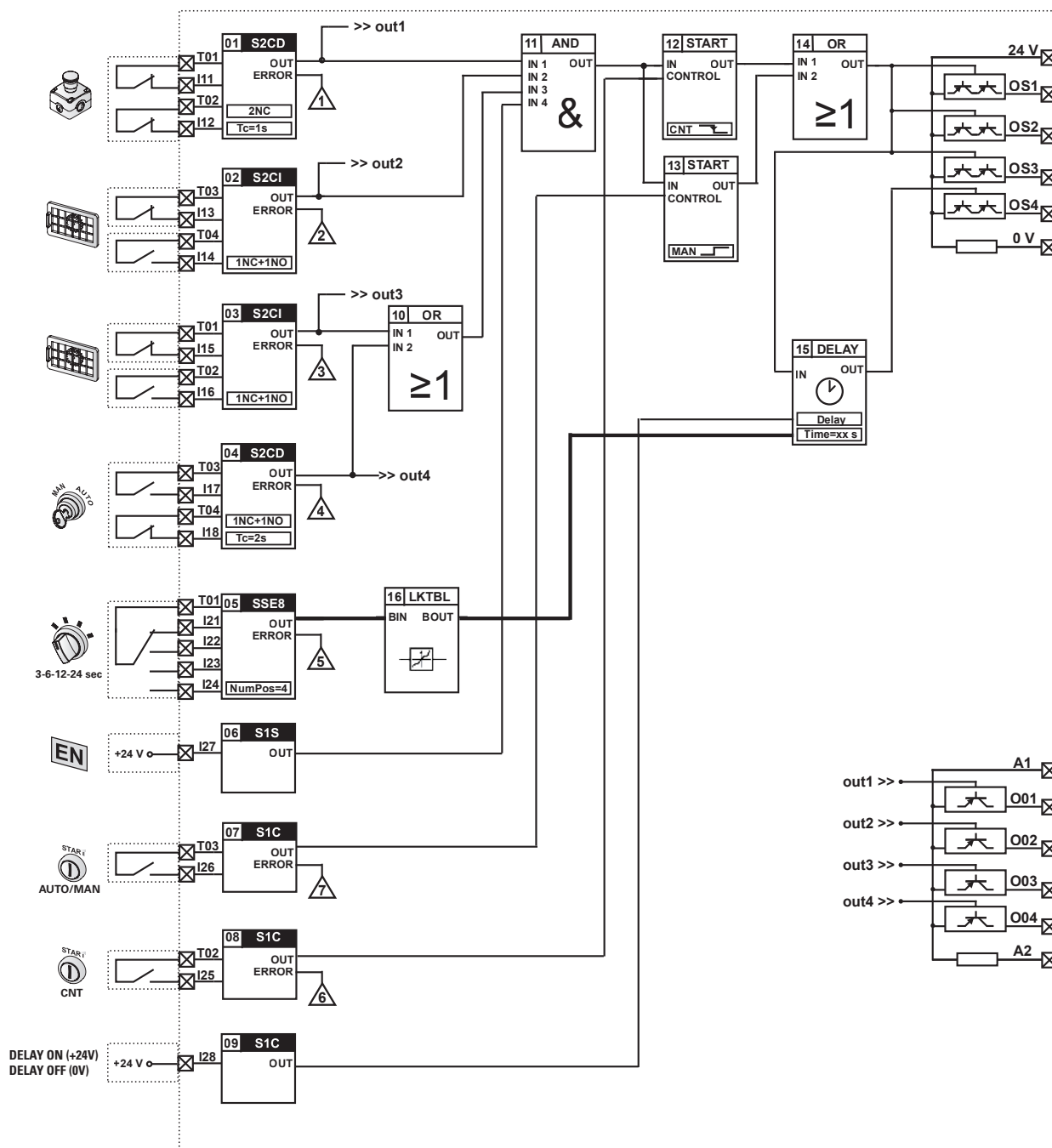



Product code
CS MF202M0-P7

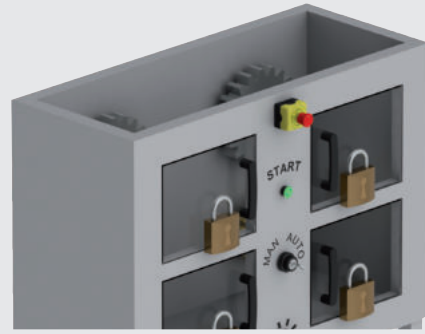

Main functions

- Monitoring of 4 guards with switches with guard locking, operating principle "D" (guard locked if solenoid is de-energised)
- 1 emergency stop
- Monitored start

Outputs

- 2 instantaneous outputs and 2 delayed PNP safety outputs with selector switch with 4 times
- 4 PNP signalling outputs
- OS4 output for door locking control

Technical data: see CS MP202M0
Dimensions, cable cross sections, terminal tightening torque: page 317, design C
Internal block diagram: page 320
Terminal layout: page 320

Application program: P7

The application program stored in the module executes one or more safety functions, as shown in the following block diagram:

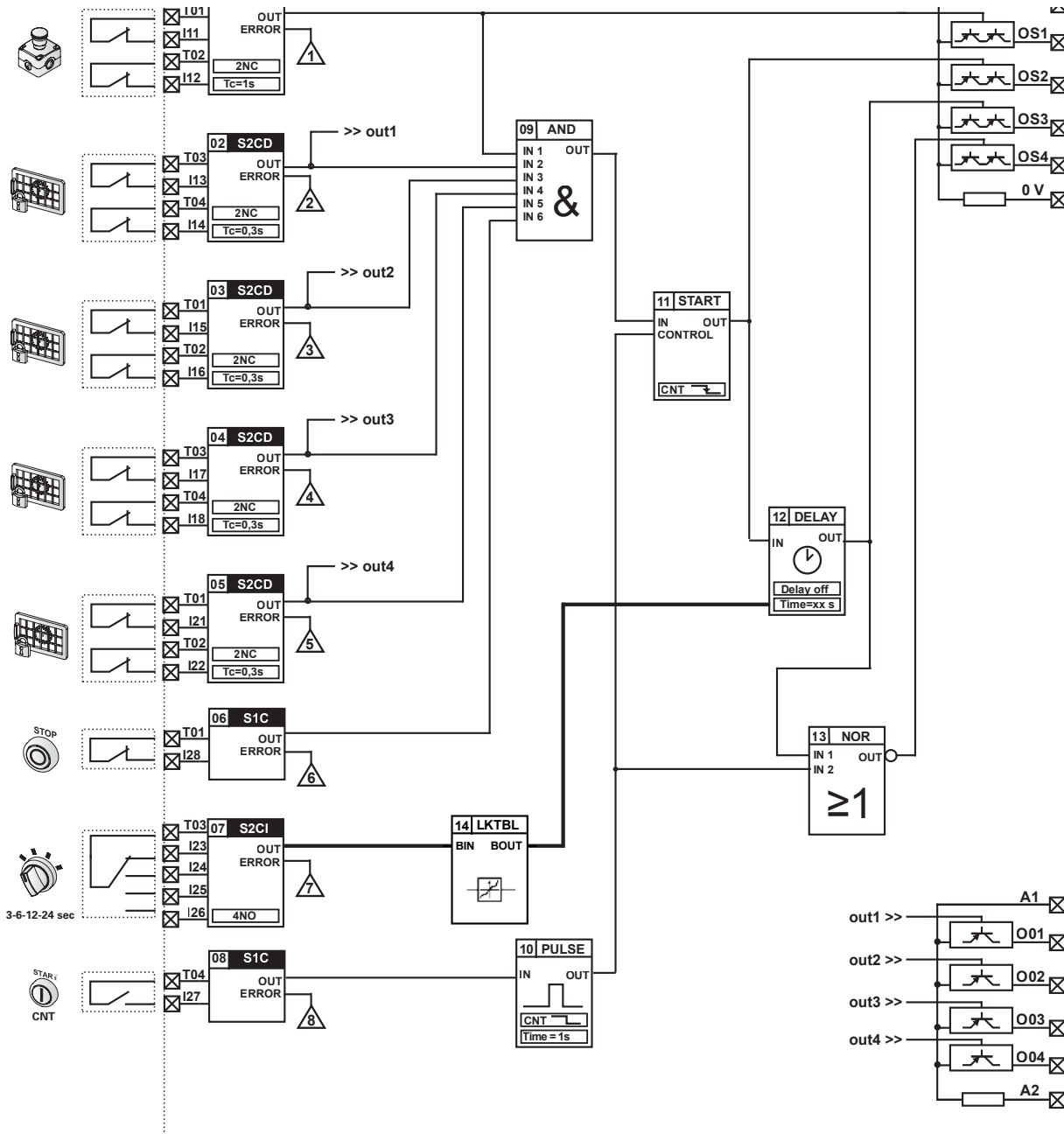



Product code
CS MF202M0-P8

Main functions

- Monitoring of 4 guards with switches with guard locking, operating principle "E" (guard locked if solenoid is energised)
- 1 emergency stop
- Monitored start

Outputs

- 2 instantaneous outputs and 2 delayed PNP safety outputs with selector switch with 4 times
- 4 PNP signalling outputs
- OS4 output for door locking control

Technical data: see CS MP202M0
Dimensions, cable cross sections, terminal tightening torque: page 317, design C
Internal block diagram: page 320
Terminal layout: page 320

Application program: P8

The application program stored in the module executes one or more safety functions, as shown in the following block diagram:

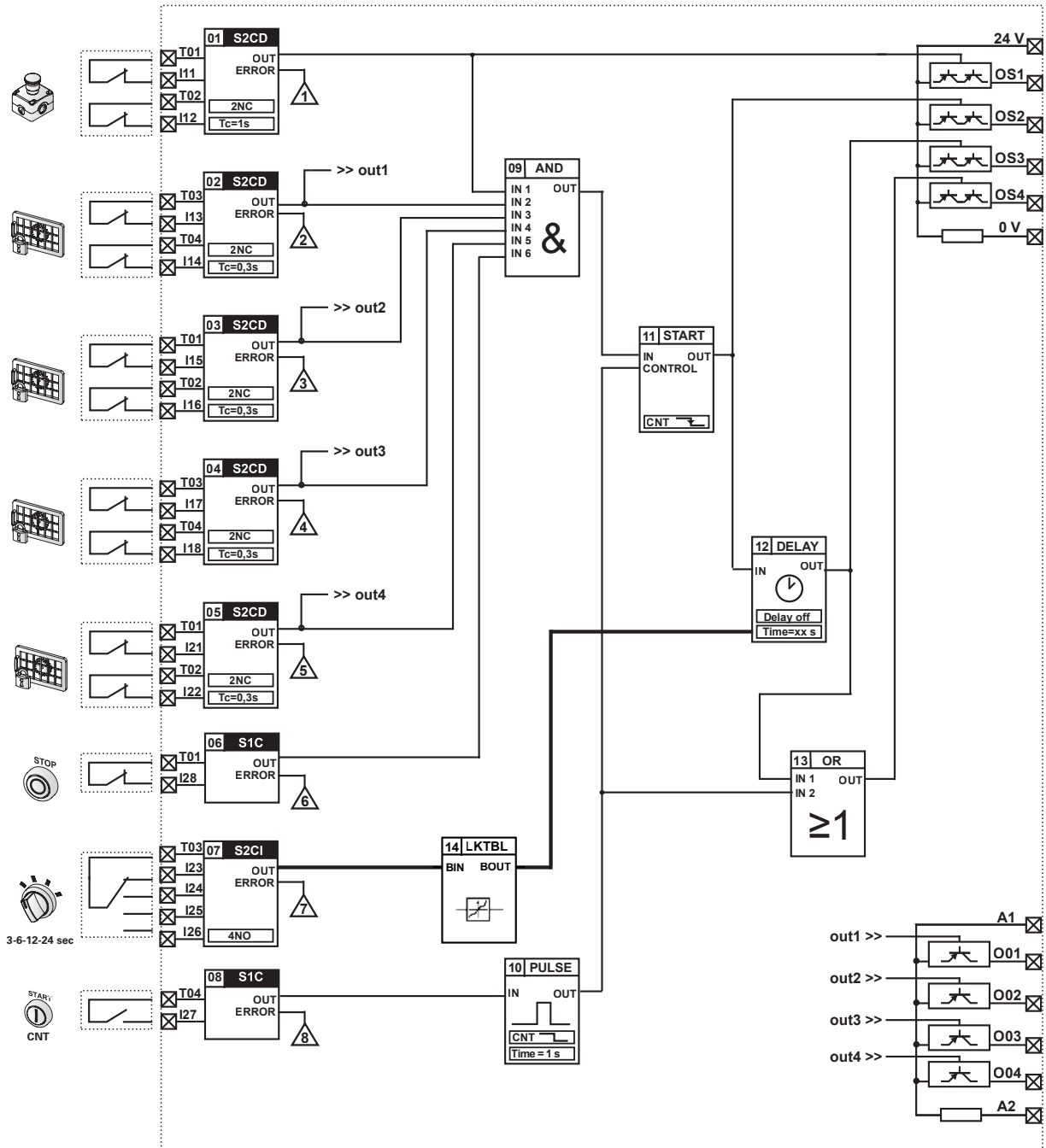

Notes: The positions of the contacts shown in the diagram are shown only as examples, and they refer to expected working conditions, with machinery in operation, guards closed, and safety devices not activated. For further explanations, please see documentation relating to each specific safety function (page 303).

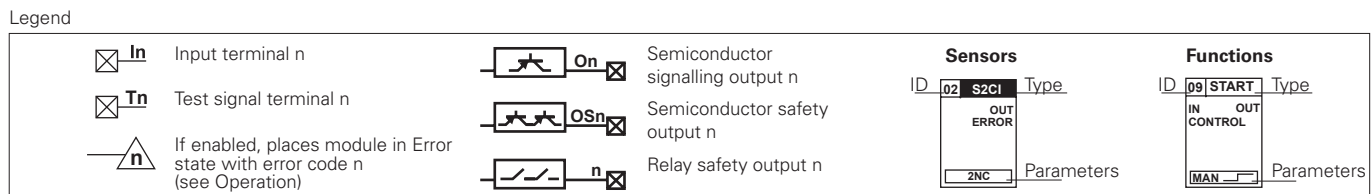

Definitions

Application program: The internal software component of this module which is aimed at the application.
“Power On” state: The device state, which lasts from the time it is switched on until the end of the internal controls.
“Run” state: The device state on completion of the “Power-On” phase (if no errors have been detected) in which the Application program is run.
“Error” state: The device state when a fault is detected. In this state, the module switches to the safe state, i.e., all safety outputs are open.
Fault: A fault can be internal or external to the safety module. Internal faults are autonomously detected by the module thanks to its redundant and self-monitored structure. An external fault can be detected by the application program. It follows that the definition of external fault is strictly dependent on the application (see note A).

Operation

When supplied with power, the module enters the Power-On state and runs an internal self-diagnosis. In this phase, the two processor LEDs (P1, P2) remain illuminated red for about 1 second. If the internal tests are completed without malfunction, the two LEDs are switched off, the module enters the Run state, and runs the application program. If the start tests are not passed, the module enters the Error state and the malfunction is indicated by the processor LEDs remaining illuminated red.
 The green LEDs relating to the power supply and the module inputs are not controlled by processors, and they immediately begin indicating the states of the respective inputs/outputs.
 When the module is in the RUN state, and no faults are detected, the two LEDs (P1, P2) remain switched off.
 In the Run state, the module can detect faults external to the module, for example caused by short circuits, or invalid input states (see note A). Depending on the fault type detected, the application program may place the module in error state, to indicate the malfunction. In this case, the application program can communicate an error code by making the LEDs (P1, P2) flash in sequence.
 During the Run state, simultaneously with application program execution, the module constantly runs a series of internal tests to check for correct hardware operation. If a malfunction is detected, the module state changes to Error.
 Once in Error state, the module is placed in a safe condition, that is with all the safety outputs open; the application program is no longer evaluated, and neither are the system inputs. Furthermore, the semiconductor signalling outputs are left unaltered (changes in inputs do not affect them) at the value imposed by the application program before entering the error state. To reset the module, just switch it off for the required duration (see technical data) and then switch it on again.

Note A: A short circuit is not always a fault. For example, in the case of an ordinary push button for emergency stops equipped with two NC contacts, contact opening is the signal to be evaluated and a short circuit between the two contacts is a fault. In contrast, in the case of a safety mat with 4-wire technology, the opposite is true, i.e. a short circuit between the wires is the signal to be evaluated whereas wire interruption is a fault.

Fault signalling

LED PWR	LED P1 and P2	Possible fault cause
Off	Off	No power supply, incorrect connections, power wires cut, external fuses broken. Module fault.
Green	Off	Normal operation.
Green	Red	Non-restorable fault. Recommended action: Send module for repair.
Green	Red x 1 Blue x 1	Restorable fault: Overcurrent on Tx or Ox outputs. Recommended action: Disconnect the semiconductor signalling outputs (Ox) and the test outputs (Tx) to check whether an external short circuit is present.
Green	Red x 1 Blue x 2	Restorable fault. Problem detected on OSx (short circuit towards earth or positive pole, or else short circuit between two OSx). Suggested action: Disconnect the safety outputs to check if there are any problems on the external connections of the OSx outputs.
Green	Red x 1 Blue x 3	Restorable fault. Module temperature outside the limits. Recommended action: Restore module temperature to within permissible limits.
Green	Blue x N	Module entered Error state at the request of the application program. Error code N. Typically due to incorrect input conditions (external short circuits, status not permitted). Recommended action: Disconnect the inputs to find any short circuits. Check the documentation supplied with the application program for further details.

**Quick description of the main safety functions (CS MF•••••)****SENSORS**

Sensor	S1C	Monitoring of one contact
Outputs	OUT	The OUT output is active when the input is closed and there is no error
	ERROR	The ERROR output is active in the case where an electrical malfunction is detected in the input signal
Parameters	None	
Examples	Start button; Stop button; Simple contact	

Sensor	S1S	Monitoring of one static signal
Outputs	OUT	The OUT output is active if 24 Vdc is applied to the input
Parameters	None	
Examples	Generic sensors with PNP output; Enabling signals	

Sensor	S2CD	Monitoring of two dependent contacts
Outputs	OUT	The OUT output is active when both inputs are in normal or safety state and there is no error
	ERROR	The ERROR output is active in the case where simultaneity times are not respected, or in the case where an electrical malfunction is detected at the input signals
Parameters	2NC / 1NO+1NC	Contact position in normal or safety state
	Tc	Max. time of simultaneity in seconds
Examples	Emergency stop button; Rope switch; Switch with two linked contacts; Mode selector with two settings, changeover; Two individual switches with a time dependency	

Sensor	S2CI	Monitoring of two independent contacts
Outputs	OUT	The OUT output is active when both inputs are in normal or safety state and there is no error
	ERROR	The ERROR output is active in the case where an electrical malfunction is detected in the input signals
Parameters	2NC / 1NO+1NC	Contact position in normal or safety state
Examples	Two switches; Magnetic sensor	

Sensor	SSE8	Mode selector with 2 to 8 positions
Outputs	OUT	The output gives a numerical value of 1 to 8 corresponding to the active input, 0 in case of error
	ERROR	The ERROR output is active if multiple inputs are active or if no input is active, or if an electrical failure is detected in the input signals
Parameters	NumPos	Number of input signals (2 to 8)
Examples	Mode selectors with a common contact and between 2 and 8 outputs	

FUNCTIONS

Function	AND	AND logical function
Outputs	OUT	The OUT output is only active if all IN input signals are present

Function	DELAY	Delayed process activation/deactivation
Outputs	OUT	The OUT output is activated if a signal is present at the IN input with a delay of Td (parameter type Don) If the signal at the IN input drops out, the OUT output is deactivated with a delay of Td (parameter type Doff)
	Parameters	Don / Doff Td
		Delay type, Don (delay on) on activation or Doff (delay-off) on cut-off Length of delay on activation or cut-off

Function	NOR	NOR logical function
Outputs	OUT	The OUT output is only active in the absence of all IN input signals

Function	OR	OR logical function
Outputs	OUT	The OUT output is only active if at least one IN input signal is present

Function	PULSE	Activation of a process for a short time
Outputs	OUT	The OUT output is activated on the IN signal falling edge and remains active for the time set by Tp
Parameters	Tp	Pulse duration

Function	START	Activation of a process
Outputs	OUT	The OUT output is activated by the edge (see parameters) of the CONTROL signal if the IN input signal is present. Thus, it remains active as long as the signal is present at IN
Parameters	MAN / CNT	MAN = activation on rising edge, CNT = activation on falling edge

Function	LKTBL	Lookup table; Conversion table between data of the same type
Outputs	BOUT	Converted data at output. Initial value = 0.
Parameters	Number of data	Number of data present in the table

Disclaimer:

Subject to modifications without prior notice and errors excepted. The data given in this sheet are accurately checked and refer to typical mass production values. The device descriptions and its applications, the fields of application, the external control details, as well as information on installation and operation, are provided to the best of our knowledge. This does not in any way mean that the characteristics described may entail legal liabilities extending beyond the "General Terms of Sale", as stated in the Pizzato Elettrica general catalogue. The customers/user is required to read our information and recommendations as well as the pertinent technical provisions before using the products for his own purposes.

Design A, housing thickness 22.5 mm

Connection data

Terminal tightening torque:	0.5 ... 0.6 Nm
Cable cross section:	0.2...2.5 mm ² 24...12 AWG

Installation

Snap-mounting on DIN rails

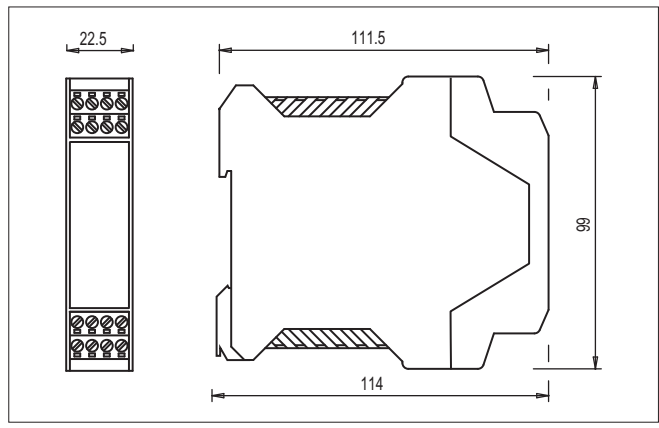

Connector with screw terminals

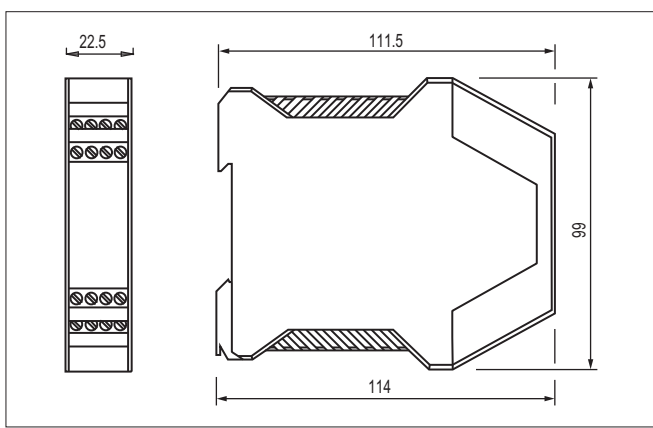

Screw terminals

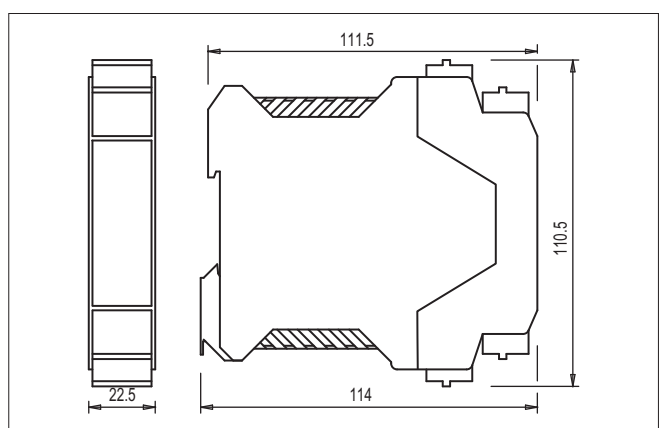

Connector with spring terminals

Design B, housing thickness 22.5 mm

Connection data

Terminal tightening torque:	0.5 ... 0.6 Nm
Cable cross section:	0.2...2.5 mm ² 24...12 AWG

Installation

Snap-mounting on DIN rails

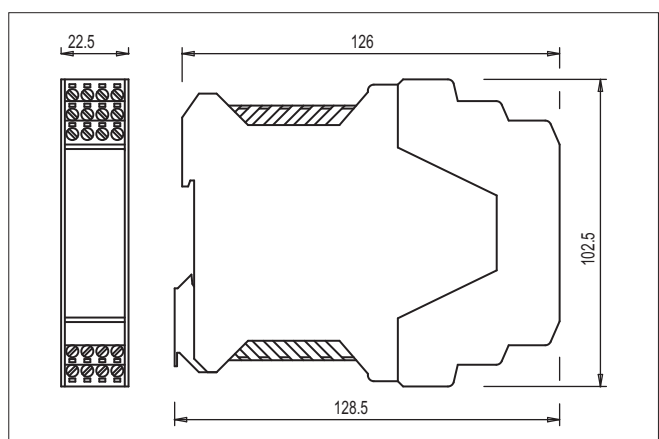

Connector with screw terminals

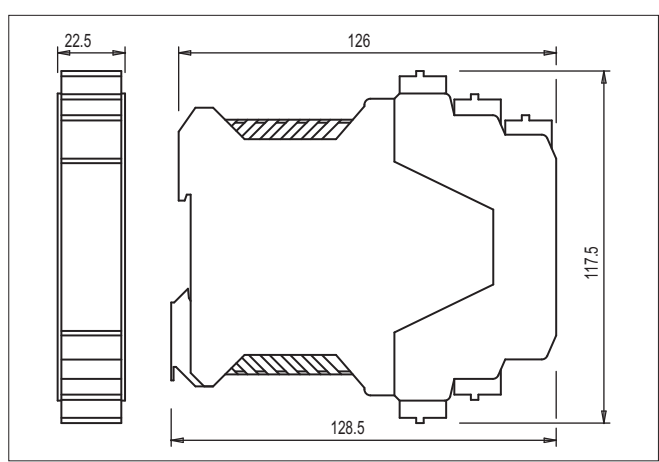

Connector with spring terminals

All values in the drawings are in mm



Design C, housing thickness 45 mm

Connection data
 Terminal tightening torque: 0.5 ... 0.6 Nm
 Cable cross section: 0.2...2.5 mm²
 24...12 AWG

Installation
 Snap-mounting on DIN rails

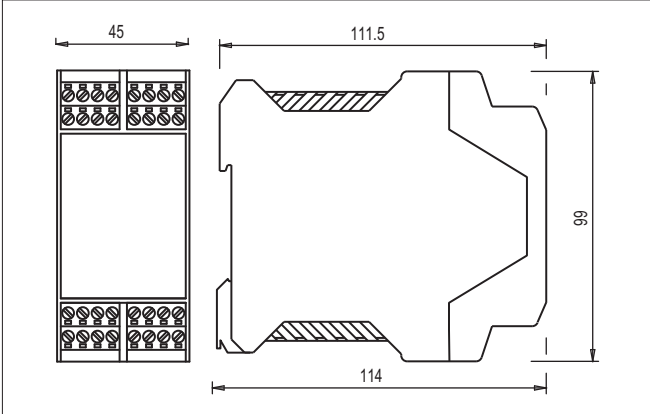

Connector with screw terminals

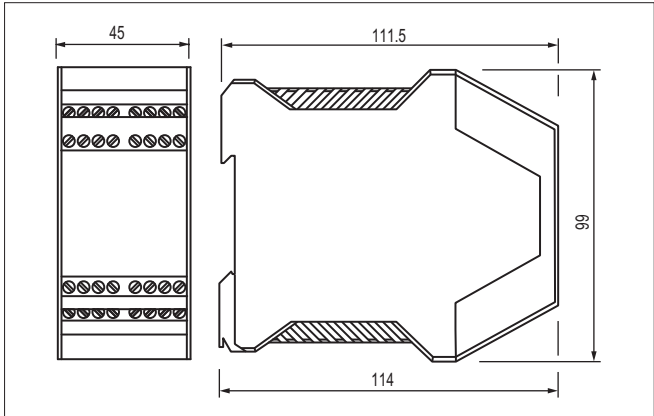

Screw terminals

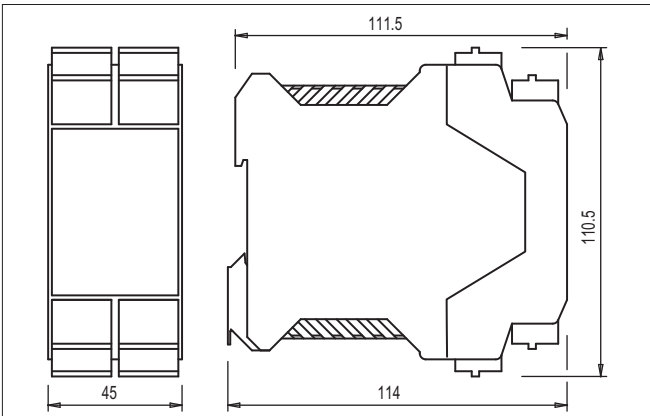

Connector with spring terminals

Design D, housing thickness 22.5 mm

Connection data
 Terminal tightening torque: 0.5 ... 0.6 Nm
 Cable cross section: 0.2...2.5 mm²
 24...12 AWG

Installation
 Snap-mounting on DIN rails

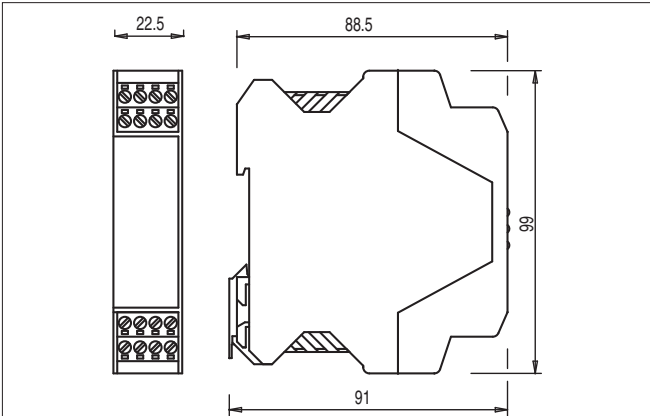

Connector with screw terminals

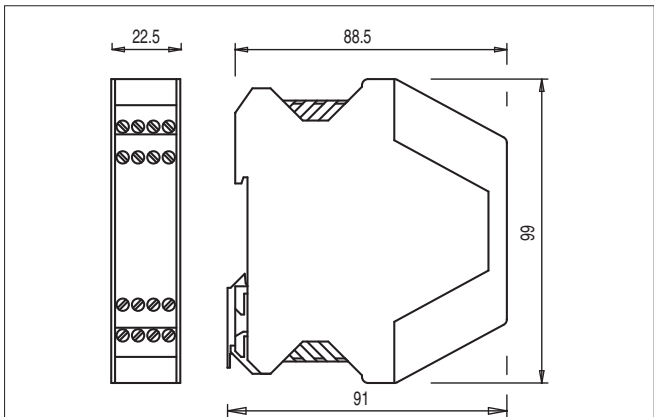

Screw terminals

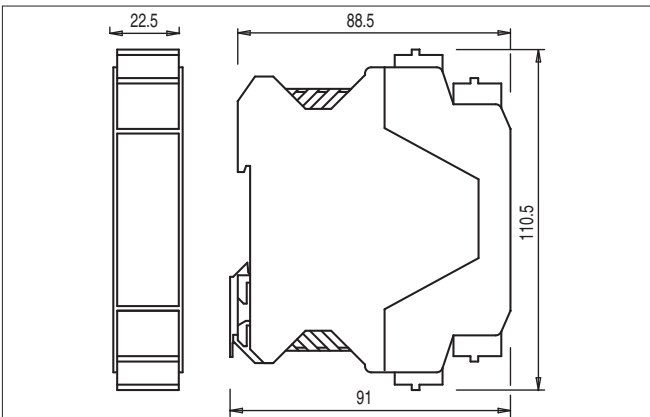

Connector with spring terminals

All values in the drawings are in mm

Design E, housing thickness 67.5 mm

Connection data

Terminal tightening torque:	0.5 ... 0.6 Nm
Cable cross section:	0.2...2.5 mm ² 24...12 AWG

Installation

Snap-mounting on DIN rails

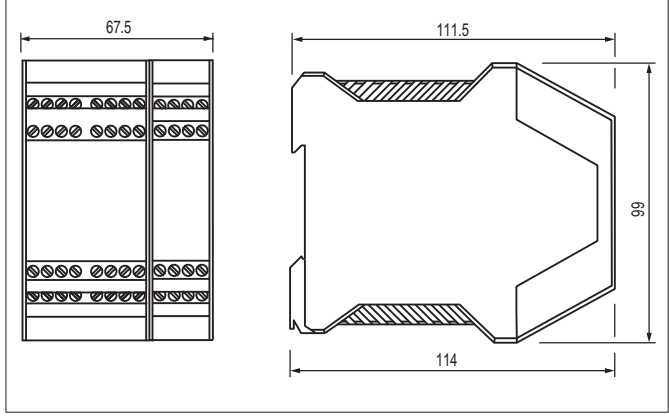

Screw terminals

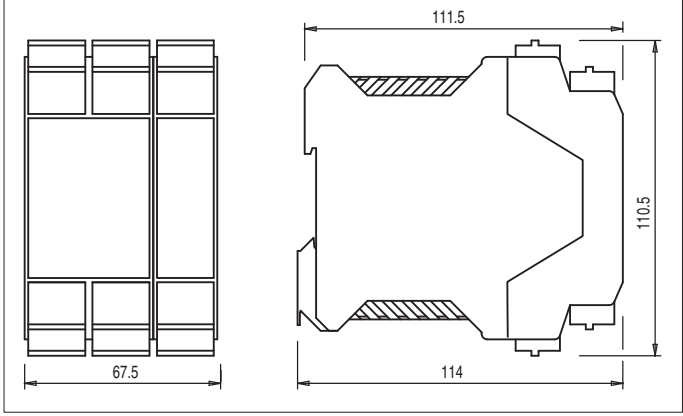

Connector with spring terminals

Design F, housing thickness 90 mm

Connection data

Terminal tightening torque:	0.5 ... 0.6 Nm
Cable cross section:	0.2...2.5 mm ² 24...12 AWG

Installation

Snap-mounting on DIN rails

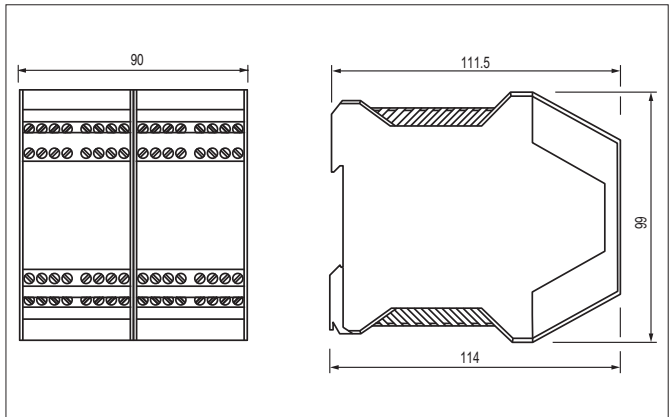

Screw terminals

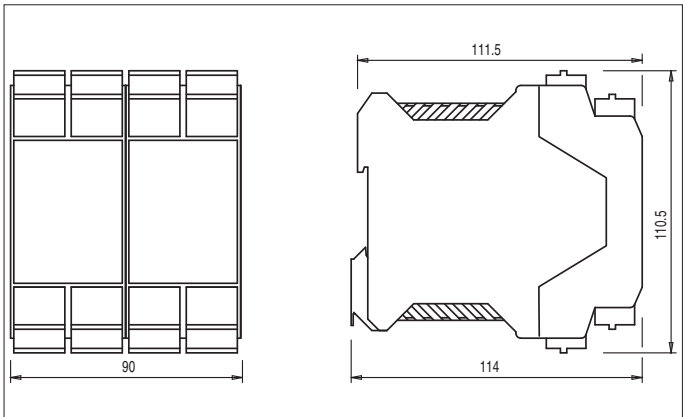

Connector with spring terminals

All values in the drawings are in mm



Pin assignment CS MF series

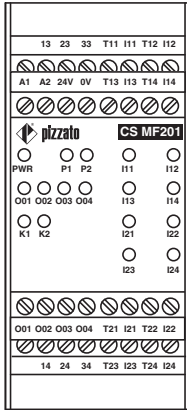

CS MF201

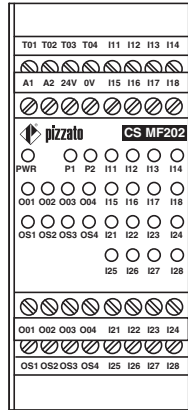

CS MF202

CS MF series internal block diagram

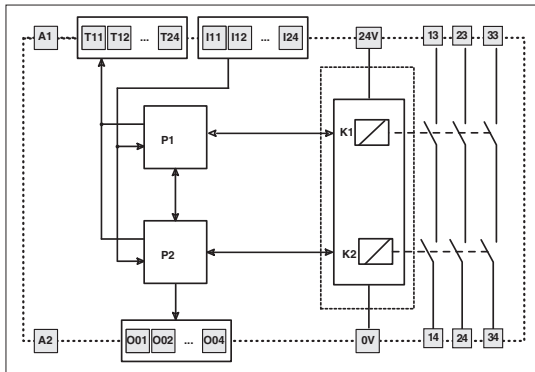

CS MF201

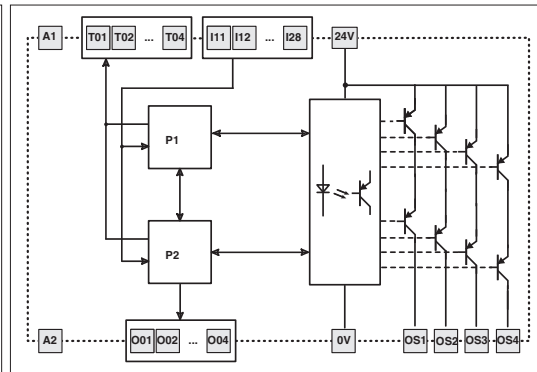

CS MF202