

Introduction



GEMNIS

A **Gemnis** series module is a programmable safety device, which allows several safety functions to be carried out simultaneously. This product series has been developed specifically to meet the needs of machinery manufacturers for machines with a low to average number of safety functions. As an indication, these modules can manage small applications which are equivalent to the functions carried out by 3 to 4 traditional electromechanical safety modules, up to circuits with dozens of inputs.

Gemnis series safety modules can implement safety circuits with a safety category of up to SIL 3 acc. to EN 62061, PL e and category 4 acc. to EN ISO 13849-1.

The **Gemnis** series of safety modules has been updated to **version 11.7** which introduces new functions and improved hardware- and software-level performance. This update considerably increases the application potential of these products.

The **Gemnis Studio** program is a graphic development environment for the creation, simulation and debugging of programs that are uploaded to the corresponding modules of the Gemnis family.

This software is licensed to users wishing to program these modules, subject to prior registration at www.gemnis.com.

You can download the new **Gemnis Studio** software version (**Gemnis Studio 11.7**) from the site, which will allow you to program both current, **Gemnis K11**-designated modules, as well as previous ones.

General features of safety modules

Gemnis series modules can manage all of the following safety device types.

- Mechanical safety switches
- Switches with solenoid for guard interlock
- Magnetic safety sensors
- Safety light barriers or optical safety sensors (category 4)
- Safety sensors
- Mushroom buttons for emergency stop
- Rope switches for emergency stop
- Safety mats or safety bumpers with 4-wire technology
- Category IIIA or IIIC two-hand controls
- Safety selector switches
- Enabling devices
- Analogue sensors 4-20 mA (Gemnis Studio 11)
- 0-4 kHz frequency signals (Gemnis Studio 11)
- Dual-beam muting systems (Gemnis Studio 11).

This modules are also equipped with functionality allowing you to also implement:

- safety timers;
- detection of various types of faults in safety devices or their connections;
- verification of the module's internal temperature limit values;
- status communication via USB port.

Finally, Gemnis series modules can:

- manage up to eight different electronic safety outputs or four relay outputs;
- manage various signalling outputs (not safety-related);
- status information and data settings via the USB communication port.

Gemnis design safety modules can implement safety circuits with up to SIL CL3 acc. to EN ISO 62061, PL e and category 4 acc. to EN ISO 13849-1.



Website

This product line is supported online via the www.gemnis.com website, where you can:

- download the Gemnis Studio installation package (following registration);
- download support files;
- get the most up to date version of the instruction manual;
- get examples and other support information which will be added over time;
- watch videos illustrating Gemnis Studio program operation.

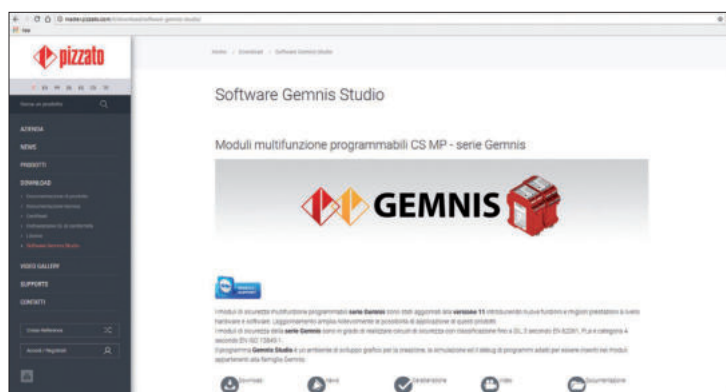
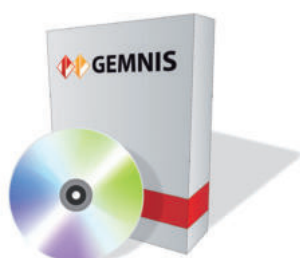



Hardware structure of the modules

Gemnis design modules are created with increased flexibility - even at the hardware level. These products are made up of various electronic circuit boards which are sold in various combinations, but which are always contained in a single housing and with one unique product code.

The Gemnis series modules have a general redundant and self monitoring type structure, they are controlled by a pair of processors which simultaneously run the application program and constantly monitor their operation and system integrity in parallel.

Each module is supplied in a single housing, of the minimum width required to house the boards which make up the module. 45 mm to 90 mm wide housings are available. The customer does not need to worry therefore about wiring the various parts.



The USB port integrated within the module is used for programming and debugging of the Gemnis Studio software module. Once a module is programmed, you can also use the USB port for communicating with a PC installed on the machine, and for the exchange of information relating to the module state.

The main hardware innovations introduced to version 11 by the safety module update are the following:

- ability to manage programs up to 4 times larger;
- the ability, with new dedicated modules, to manage analogue and/or speed inputs;
- models with 8 electronic safety outputs;
- new module configurations available (see following table).

Module	Inputs type I	Inputs type J	Inputs type C	Inputs type F	Test signals T	OS safety outputs	O signalling outputs	Port	Width (mm)	Page
CS MP201M0	8	-	-	-	8	3NO	4	USB	45	283
CS MP202M0	16	-	-	-	4	4 PNP	4	USB	45	284
CS MP203M0	12	-	-	-	4	3NO + 1NO	4	USB	45	285
CS MP204M0	12	-	-	-	4	3NO	4	USB	45	286
CS MP205M0	4	4	-	4	4	4 PNP	4	USB	45	287
CS MP206M0	8	-	-	-	4	4 PNP	12	USB	45	288
CS MP207M0	4	-	2	-	4	4 PNP	4	USB	45	289
CS MP208M0	16	-	-	-	4	8 PNP	-	USB	45	290
CS MP301M0	24	-	-	-	8	3NO	4	USB	67.5	291
CS MP302M0	24	-	-	-	12	4 PNP	4	USB	67.5	292
CS MP303M0	32	-	-	-	4	4 PNP	4	USB	67.5	293
CS MP304M0	28	-	-	-	4	3NO + 1NO	4	USB	67.5	294
CS MP305M0	24	-	-	-	4	4 PNP	12	USB	67.5	295
CS MP306M0	20	-	-	-	4	3NO + 1NO	12	USB	67.5	296
CS MP307M0	8	4	2	4	4	4 PNP	4	USB	67.5	297
CS MP308M0	24	-	-	-	4	8 PNP	8	USB	67.5	298
CS MP309M0	32	-	-	-	4	8 PNP	-	USB	67.5	299
CS MP401M0	40	-	-	-	4	4 PNP	12	USB	90	300
CS MP402M0	32	-	-	-	12	8 PNP	8	USB	90	301
CS MP403M0	40	-	-	-	4	8 PNP	8	USB	90	302

I = Digital inputs

J = Digital inputs, decoupled

C = Inputs for 4-20 mA analogue signals

F = Inputs for 0 ... 4 kHz frequency signals

T = Test signals

OS = OSSD safety outputs (PNP)

nn = Relay safety outputs

O = signalling outputs (PNP)

Software Gemnis Studio

Gemis Studio is software designed to allow the user to program a module belonging to the Gemnis line. This software has a graphical interface to visually display, in a natural and intuitive way, the assembly of operations that the application program will execute, once loaded to the module. Gemnis Studio allows you to attach supporting information and useful notes to the configuration information, for overall understanding of the program. Gemnis Studio also allows you to check correct application program operation prior to sending it to the module via the simulation.

Finally, Gemnis Studio allows you to carry out monitoring and detection operations, and to graphically represent the state of an active operational device in real time.

New release 11.7 available

In the latest version of Gemnis Studio 11.7.1.0 the following new features have been introduced:

- "SERIAL" function block for communication with PLC;
- program migration tool;
- new settings available in the "MUTING" and "EDM" function blocks;
- new parameters available in the "Display" object;
- new graphic features (colouring of the terminals of the function blocks according to the connection; option of setting the "minimal" display of the connections; updated images of the safety devices and sensors available in the library);
- possibility to export in PDF format the printouts of the program and of the report.



Desktop

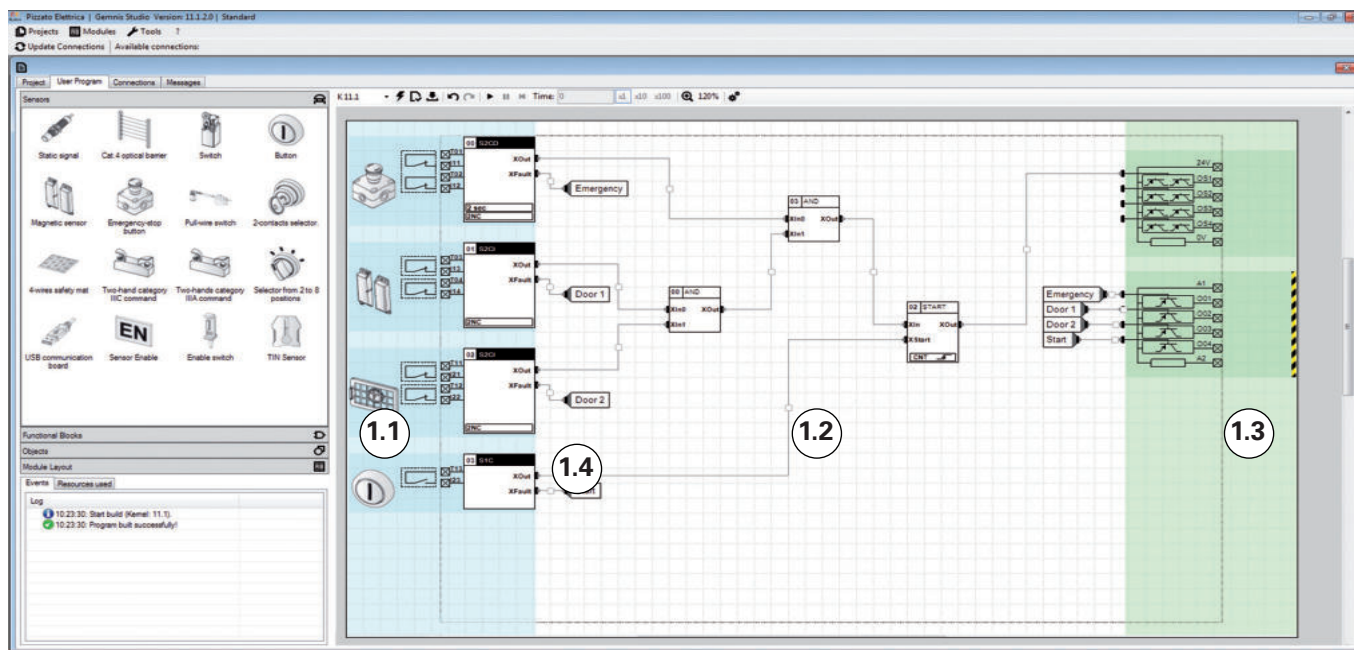

The Gemnis Studio software has been designed with the objective of making Gemnis series module operation as immediate and visual as possible. With this aim, we decided to create a work environment – the Desktop – where, as far as possible, the user can amass all the information required to actually "view" and not just "imagine" the behaviour of the project under development. This is the reason we have made room for graphical object representations, of the physical characteristics of the module in use, and immediate interaction, by means of simulation, with the created program.

The desktop is the main user work area, the zone where the flow and processing to be applied to the data detected by the module are defined using the graphical program interface.

The desktop is divided into three parts:

- 1.1) the sensor zone
- 1.2) the functional block zone
- 1.3) the output zone

In the sensor zone (1.1) the user indicates the external device types connected to the module terminals, and all the parameters needed to define them.

In the output zone (1.3) all the output devices present in the selected module (relays, transistors etc.) are immediately shown.

In the function block zone (1.2) the user will enter all the logical functions needed to process the flow of data coming from the sensors, and will proceed to make the connections to transfer this data between the objects in the desktop and finally to the outputs.

The desktop includes a dotted box (1.4) which represents the area "occupied by the module", or, everything enclosed within the physical module, from terminals to code. The area outside this box, meanwhile, is occupied by images of the physical devices external to the module (switches, buttons, etc.), illustrating their expected internal structure and any description.

At the user's request, the desktop content is compiled and, provided there are no errors, it is translated into the application program. If a module is connected to the computer, you can immediately transfer the application program to it, and thereby check its effective operation in the field.

Otherwise it is possible to simulate application program operation directly on the desktop, by interacting with the sensors and evaluating their effects graphically.

Project

The collection of information required to configure a module and describe its activities is called a "Project". Using Gemnis Studio, the user can assemble the textual and graphical information required to elaborate and comment the functions which will be carried out by the program, once installed on a Gemnis line module.

Printing

Gemis Studio can generate a Connection Report, which includes all connections to the module terminals, and a user Program Report, allowing you to print the Application Program.

Password

The password gives the option of protecting a module's interaction capacity, and the ability to modify the project file.



Sensors

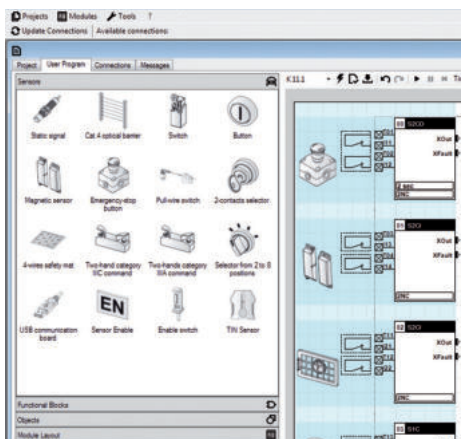

The sensor zone indicates the external device types which can be connected to the module terminals, and all the parameters needed to define them.

Each sensor created displays a view of the internal contact configuration and of how the contacts are connected to the module terminals, a box with the associated safety function, and the parameters selected for the function.

From the sensor panel, you can select a sensor using the mouse and drag it into the dedicated desktop area.

A full list of the available sensors is shown on the side.

Sensor list

Sensor type	Diagram	Examples
Sensor with 1 not testable channel		
Sensor with 2 not testable channels, with interdependent signals		
Sensor with 1 tested channel		
Sensor with 2 independent tested channels		
Sensor with 2 dependent tested channels		
Sensor with 2 always-closed tested channels, short circuit permitted between the channels		
Sensor with 2 tested channels which can be crossed		
Sensor with 2 tested channels which cannot be crossed		
Sensor with 2 to 8 tested channels which cannot be crossed and which may only be active one at a time		
Sensor with 2 tested channels which cannot be crossed and which must follow a very precise activation/deactivation sequence made up of three states: rest, work, stop		
Dual temperature sensor integrated in module		
Monitoring of a pair of analogue sensors with 4-20 mA output in both 2-wire and 3-wire versions		
Monitoring of a pair of signals with frequencies up to 4 KHz		

Function blocks

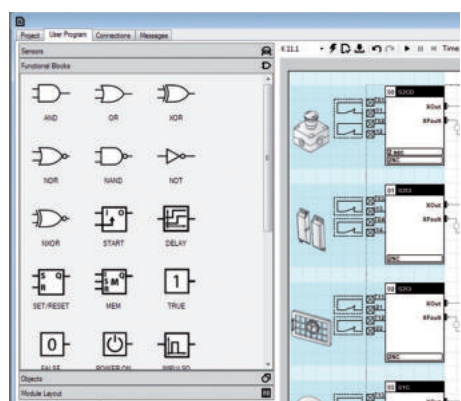

The function blocks represent all the logic functions required to process the data flow between sensors and outputs.

From the function block panel, a block can be selected using the mouse and dragged into the dedicated desktop area.

A full list of the available function blocks is shown on the side.

List of available pizzato blocks

AND Basic Boolean function	POWER ON Active signal at first execution cycle	FILTER Filters a signal from interference for a duration lower than set time
OR Basic Boolean function	PULSE Returns a signal of type Delay Off on the preselected input edge	LDC Upstream function block for monitoring of a door-locking system
XOR Basic Boolean function	CLOCK Generates pulses at pre-established fixed intervals	WAVE Generates a waveform with variable period and ON time
NOR Basic Boolean function	ERROR Puts the module into Error State	MUTE2 Upstream function block for monitoring of a 2-beam muting system
NAND Basic Boolean function	LKTBL Conversion table between data of the same type	SERIAL Allows a telegram with a length of up to 32 bits to be transmitted to any output of the module.
NOT Basic Boolean function	GEQ/EQU/LEQ Carries out a numerical comparison between two values of type B or W and displays the result in boolean format (X)	
NXOR Basic Boolean function	MESSAGE Transmits a message on the USB and COM ports	
START Control function	COUNTER Pulse counter	
DELAY Returns a signal of type Delay Off or Delay On	TRIGGER Detects the edge, either rising or falling, of an input signal	
SET/RESET Basic logical memory function		
TRUE / FALSE Basic Boolean function		

Simulation

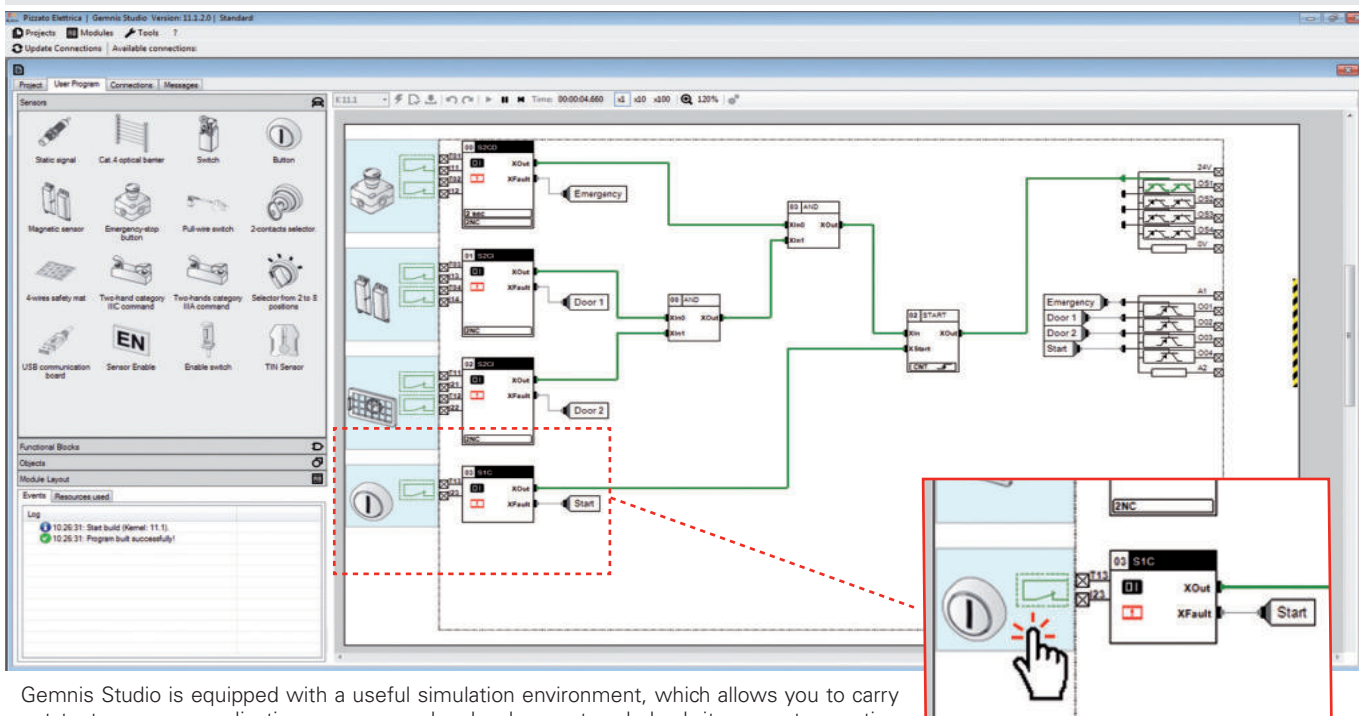

Gemis Studio is equipped with a useful simulation environment, which allows you to carry out tests on your application program under development and check its correct operation before you install it in a module. To run an application program simulation during the development phase, simply press the Start button on the toolbar at the top of the desktop. If the application program cannot be compiled, the simulation will not run.

Upon start of the simulation phase, the desktop and the way you interact with it change. During this phase you can simulate module operation by interacting with the sensors and simulating real world conditions or operations. Clicking on the sensors will make them execute, in sequence, the standard events for each sensor. Each of these interactions modifies the state of the sensor output variables which, via the connectors, will become the input variables of the function blocks, which will evaluate them and so on, until the data arrives at the outputs that will or will not activate. This simulates exactly what will happen in the module.

Transmission of the information via the connectors is visible via colour change of the connectors.

Monitor

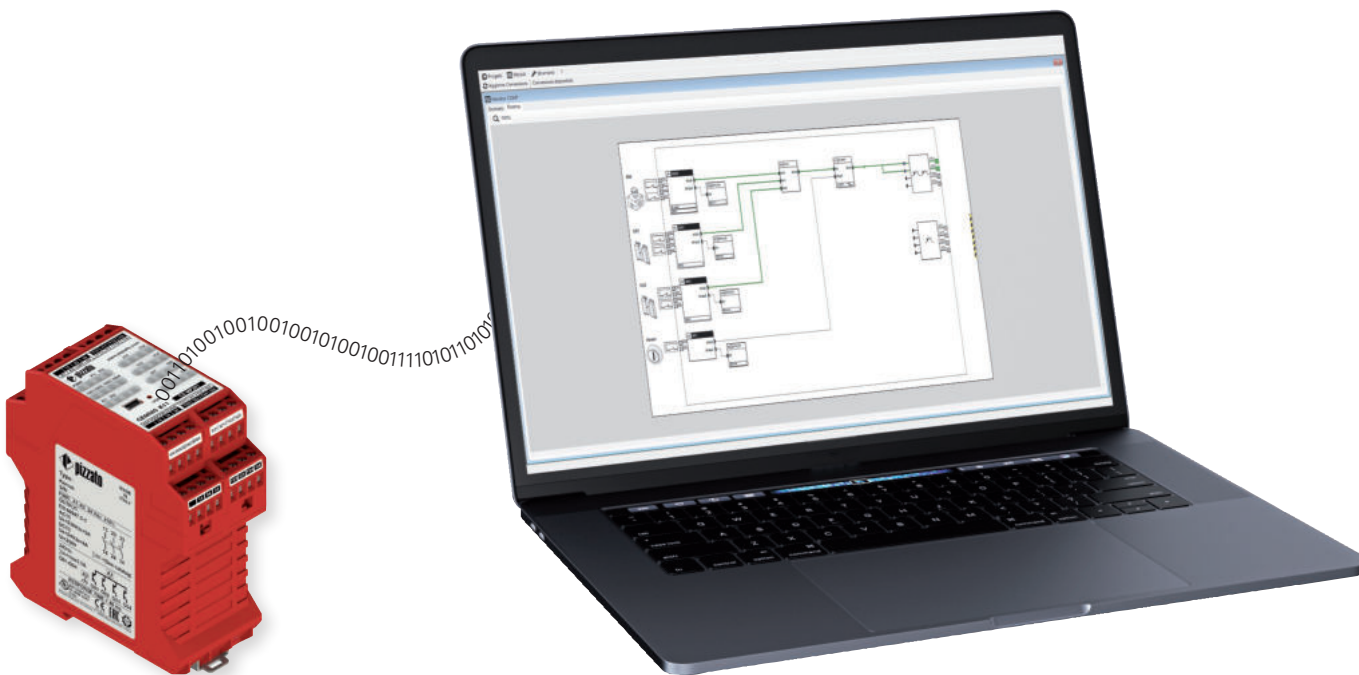

You can monitor operation of one or more Gemnis modules in real time using the Monitor function.

You can observe the overall operation state of the module and various data relating to the program being executed, including a list of most recently saved programs. The execution status of the program as well as the status of the module inputs and outputs can be viewed in real time. In Gemnis Studio 11 the video data update has been made faster and graphical pan & zoom functions are also available for the analysis of large projects.

New SERIAL function block

The **SERIAL function block** was introduced with the **11.7.1.0** release of **GEMNIS STUDIO**, allowing a telegram with a length of up to 32 bits to be transmitted to any output of the module.

With the SERIAL function block it is therefore possible to export "bit" type information from a Gemnis safety module (typically the open or closed state of the guard, but also the locked or unlocked state of the guard, or results of logical combinations between other GEMNIS STUDIO function blocks) using a maximum of 2 cables and 2 module outputs.

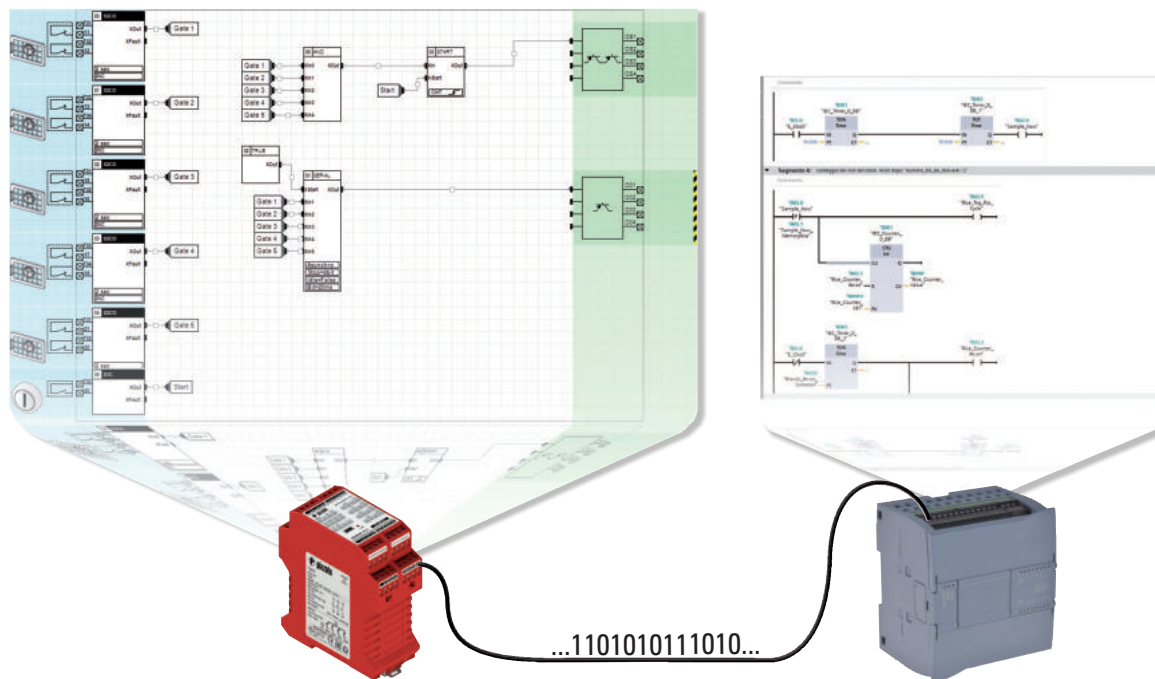

Transmission parameters

The function block allows a wide range of transmission parameters to be set:

- number of bits to be transmitted (2 to 32): any digital signal, including function block outputs;
- 2 types of transmission: synchronous (uses two outputs: signal and clock) or asynchronous (one self-synchronizing output, bit with Manchester coding);
- adjustable bit duration from 10 to 500 ms;
- IDLE status of the output cable (0, 1);
- number of fill bits between two consecutive transmissions (2 to 10);
- max. transmission speed: 100 bit/s in synchronous transmission, 50 bit/s in asynchronous transmission.

Advantages for the user

- The new SERIAL function block can be used on all Gemnis modules, even on previously purchased ones.
- **No hardware upgrade costs.**
- Simply download the **new release of Gemnis Studio 11.7.1.0**
- Less outputs occupied in the module: 1 single output for transmitting up to 32 bits.
- Less wiring: only 1 or 2 wires are required.
- No need for a PC with USB connection to the safety module.
- The pulse sequence can be decoded with any type of PLC.

Technical support

Pizzato Elettrica provides technical support free of charge to users who have registered on the website and downloaded Gemnis Studio.

The information requested must be relevant to the functionality of the module. We do not provide a consulting service based on the customer's application.



Online support

The site www.gemnis.com contains video tutorials illustrating Gemnis Studio program operation.

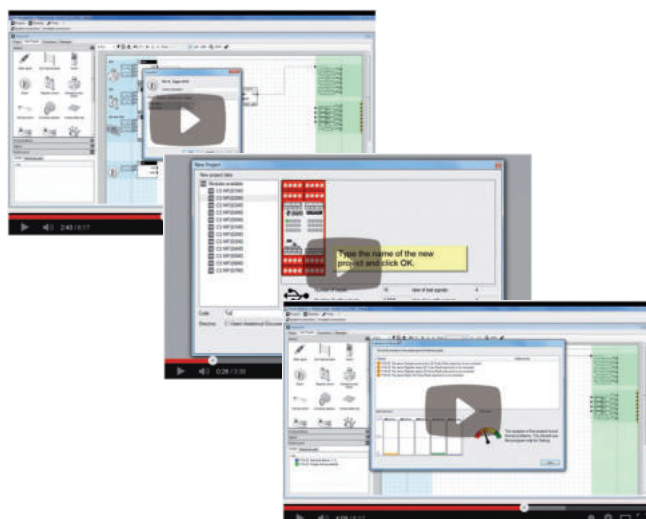

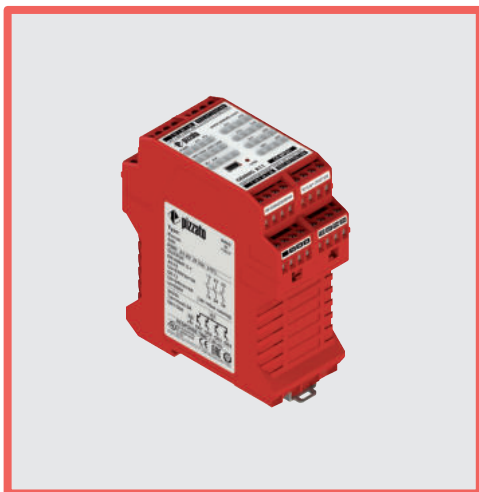

Main features

- For safety applications up to SIL CL 3/PL e
- Supply voltage: 24 Vdc
- Gemnis Studio for easy and intuitive programming and program simulation
- Large selection of logical blocks for the management of external devices and programs
- Custom configured versions available on request

Quality marks:



EC type examination certificate: M6A 16 06 75157 010
 UL approval: E131787
 CCC approval: 2013010305640211
 TÜV SÜD approval: Z10 16 05 75157 009
 EAC approval: RU C-IT.YT03.B.00035/19

General data

Parameter:	Value:	Page:
SIL CL acc. to EN IEC 62061	up to SIL CL 3	
Performance Level (PL) acc. to EN ISO 13849-1	up to PL e	
Safety category acc. to EN ISO 13849-1	up to cat. 4	
MTTF _D	135	
PFH _D	1.44E-09	
Mission time	20 years	
System response time	< 40 ms	
Dimensions (HxLxW)	111.5x45x99 mm	
Housing data		303 part 1
Environmental data		303 part 2
Supply		303 part 3
In compliance with standards		303 part 4
Programming software	Gemis Studio	303 part 5
USB port	Yes	
Safety inputs (Ix)	8	303 part 6
Test outputs (Tx)	8	303 part 10
Semiconductor signalling output circuits (Ox)	4	303 part 11
Safety relay circuits	3NO	303 part 14

Pin assignment

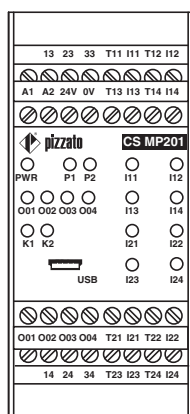

Internal block diagram

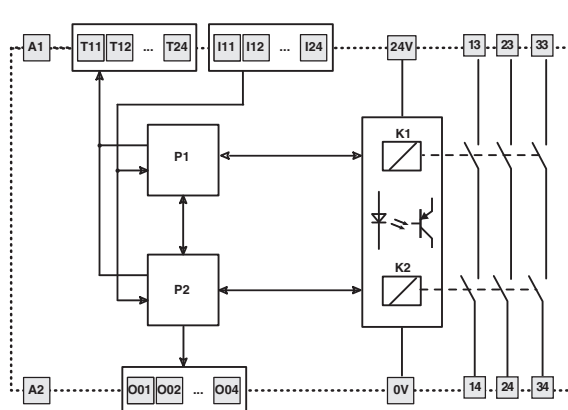

Code structure

CS MP201M0

Connection type

- M** Connector with screw terminals
- X** Connector with spring terminals



Main features

- For safety applications up to SIL CL 3/PL e
- Supply voltage: 24 Vdc
- Gemnis Studio for easy and intuitive programming and program simulation
- Large selection of logical blocks for the management of external devices and programs
- Custom configured versions available on request

General data

Parameter:	Value:	Page:
SIL CL acc. to EN IEC 62061	up to SIL CL 3	
Performance Level (PL) acc. to EN ISO 13849-1	up to PL e	
Safety category acc. to EN ISO 13849-1	up to cat. 4	
MTTF _D	614	
PFH _D	1.32E-09	
Mission time	20 years	
System response time	< 30 ms	
Dimensions (HxLxW)	111.5x45x99 mm	
Housing data		303 part 1
Environmental data		303 part 2
Supply		303 part 3
In compliance with standards		303 part 4
Programming software	Gemis Studio	303 part 5
USB port	Yes	
Safety inputs (Ix)	16	303 part 6
Test outputs (Tx)	4	303 part 10
Semiconductor signalling output circuits (Ox)	4	303 part 11
Semiconductor safety output circuits (OSx)	4 PNP	303 part 12

Quality marks:



EC type examination certificate: M6A 16 06 75157 010
 UL approval: E131787
 CCC approval: 2013010305640211
 TÜV SÜD approval: Z10 16 05 75157 009
 EAC approval: RU C-IT.YT03.B.00035/19

Pin assignment

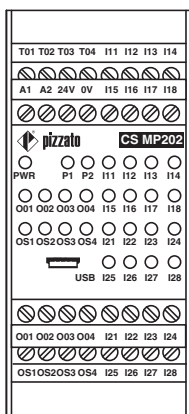

Internal block diagram

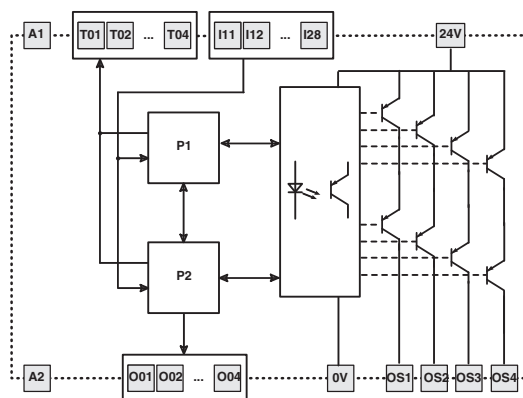

Code structure

CS MP202M0

Connection type

- M** Connector with screw terminals
- X** Connector with spring terminals



Main features

- For safety applications up to SIL CL 3/PL e
- Supply voltage: 24 Vdc
- Gemnis Studio for easy and intuitive programming and program simulation
- Large selection of logical blocks for the management of external devices and programs
- Custom configured versions available on request

Quality marks:



EC type examination certificate: M6A 16 06 75157 010
 UL approval: E131787
 CCC approval: 2013010305640211
 TÜV SÜD approval: Z10 16 05 75157 009
 EAC approval: RU C-IT.YT03.B.00035/19

General data

Parameter:	Value:	Page:
SIL CL acc. to EN IEC 62061	up to SIL CL 3	
Performance Level (PL) acc. to EN ISO 13849-1	up to PL e	
Safety category acc. to EN ISO 13849-1	up to cat. 4	
MTTF _D	103	
PFH _D	1.61E-09	
Mission time	20 years	
System response time	< 40 ms	
Dimensions (HxLxW)	111.5x45x99 mm	
Housing data		303 part 1
Environmental data		303 part 2
Supply		303 part 3
In compliance with standards		303 part 4
Programming software	Gemis Studio	303 part 5
USB port	Yes	
Safety inputs (Ix)	12	303 part 6
Test outputs (Tx)	4	303 part 10
Semiconductor signalling output circuits (Ox)	4	303 part 11
Safety relay circuits	3NO+1NO	303 part 14

Pin assignment

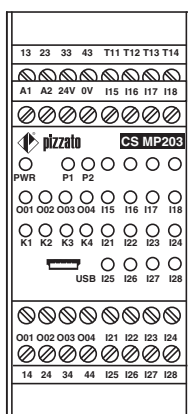

Internal block diagram

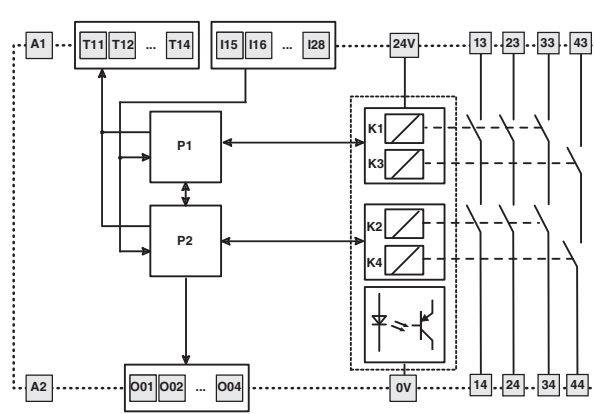

Code structure

CS MP203M0

Connection type

- M** Connector with screw terminals
- X** Connector with spring terminals



Main features

- For safety applications up to SIL CL 3/PL e
- Supply voltage: 24 Vdc
- Gemnis Studio for easy and intuitive programming and program simulation
- Large selection of logical blocks for the management of external devices and programs
- Custom configured versions available on request

Quality marks:



EC type examination certificate: M6A 16 06 75157 010
 UL approval: E131787
 CCC approval: 2013010305640211
 TÜV SÜD approval: Z10 16 05 75157 009
 EAC approval: RU C-IT.YT03.B.00035/19

General data

Parameter:	Value:	Page:
SIL CL acc. to EN IEC 62061	up to SIL CL 3	
Performance Level (PL) acc. to EN ISO 13849-1	up to PL e	
Safety category acc. to EN ISO 13849-1	up to cat. 4	
MTTF _D	134	
PFH _D	1.52E-09	
Mission time	20 years	
System response time	< 40 ms	
Dimensions (HxLxW)	111.5x45x99 mm	
Housing data		303 part 1
Environmental data		303 part 2
Supply		303 part 3
In compliance with standards		303 part 4
Programming software	Gemis Studio	303 part 5
USB port	Yes	
Safety inputs (Ix)	12	303 part 6
Test outputs (Tx)	4	303 part 10
Semiconductor signalling output circuits (Ox)	4	303 part 11
Safety relay circuits	3NO	303 part 14

Pin assignment

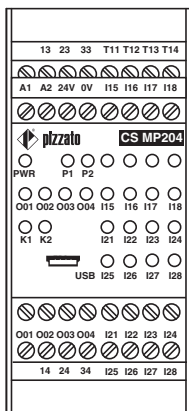

Internal block diagram

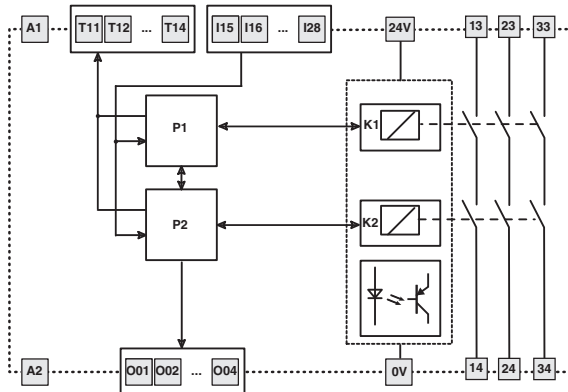

Code structure

CS MP204M0

Connection type

- M** Connector with screw terminals
- X** Connector with spring terminals



Main features

- For safety applications up to SIL CL 3/PL e
- Supply voltage: 24 Vdc
- Gemnis Studio for easy and intuitive programming and program simulation
- Large selection of logical blocks for the management of external devices and programs
- Custom configured versions available on request

Quality marks:



EC type examination certificate: M6A 16 06 75157 010
 UL approval: E131787
 CCC approval: 2013010305640211
 TÜV SÜD approval: Z10 16 05 75157 009
 EAC approval: RU C-IT.YT03.B.00035/19

General data

Parameter:	Value:	Page:
SIL CL acc. to EN IEC 62061	up to SIL CL 3	
Performance Level (PL) acc. to EN ISO 13849-1	up to PL e	
Safety category acc. to EN ISO 13849-1	up to cat. 4	
MTTF _D	373	
PFH _D	2.19E-09	
Mission time	20 years	
System response time	< 30 ms	
Dimensions (HxLxW)	111.5x45x99 mm	
Housing data		303 part 1
Environmental data		303 part 2
Supply		303 part 3
In compliance with standards		303 part 4
Programming software	Gemis Studio	303 part 5
USB port	Yes	
Safety inputs (Ix)	4	303 part 6
Decoupled digital inputs (Jx)	4	303 part 7
Inputs for frequency signals from 0 to 4 kHz (Fx)	4	303 part 9
Test outputs (Tx)	4	303 part 10
Semiconductor signalling output circuits (Ox)	4	303 part 11
Semiconductor safety output circuits (OSx)	4 PNP	303 part 12

Pin assignment

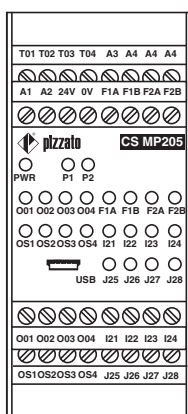

Internal block diagram

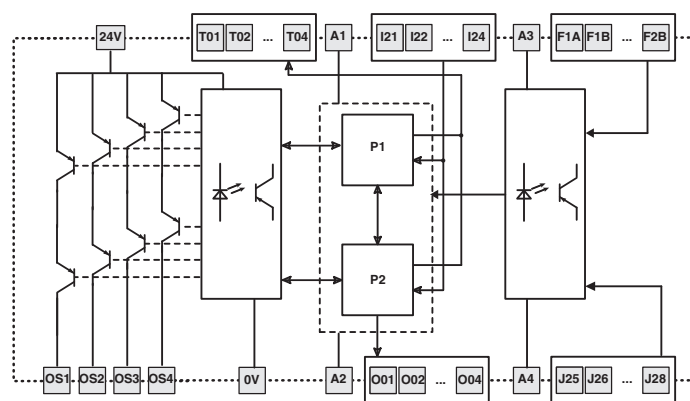

Code structure

CS MP205M0

Connection type

- M** Connector with screw terminals
- X** Connector with spring terminals



Main features

- For safety applications up to SIL CL 3/PL e
- Supply voltage: 24 Vdc
- Gemnis Studio for easy and intuitive programming and program simulation
- Large selection of logical blocks for the management of external devices and programs
- Custom configured versions available on request

General data

Parameter:	Value:	Page:
SIL CL acc. to EN IEC 62061	up to SIL CL 3	
Performance Level (PL) acc. to EN ISO 13849-1	up to PL e	
Safety category acc. to EN ISO 13849-1	up to cat. 4	
MTTF _D	3314	
PFH _D	1.09E-09	
Mission time	20 years	
System response time	< 30 ms	
Dimensions (HxLxW)	111.5x45x99 mm	
Housing data		303 part 1
Environmental data		303 part 2
Supply		303 part 3
In compliance with standards		303 part 4
Programming software	Gemis Studio	303 part 5
USB port	Yes	
Safety inputs (Ix)	8	303 part 6
Test outputs (Tx)	4	303 part 10
Semiconductor signalling output circuits (Ox)	12	303 part 11
Semiconductor safety output circuits (OSx)	4 PNP	303 part 12

Quality marks:



EC type examination certificate: M6A 16 06 75157 010
 UL approval: E131787
 CCC approval: 2013010305640211
 TÜV SÜD approval: Z10 16 05 75157 009
 EAC approval: RU C-IT.YT03.B.00035/19

Pin assignment

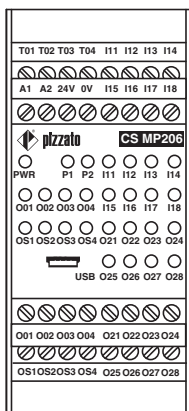

Internal block diagram

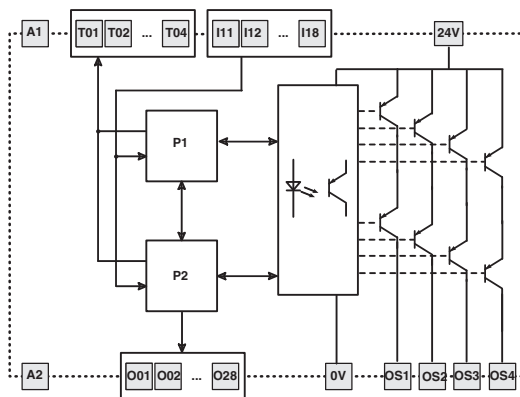

Code structure

CS MP206M0

Connection type

- M** Connector with screw terminals
- X** Connector with spring terminals



Main features

- For safety applications up to SIL CL 3/PL e
- Supply voltage: 24 Vdc
- Gemnis Studio for easy and intuitive programming and program simulation
- Large selection of logical blocks for the management of external devices and programs
- Custom configured versions available on request

Quality marks:



EC type examination certificate: M6A 16 06 75157 010
 UL approval: E131787
 CCC approval: 2013010305640211
 TÜV SÜD approval: Z10 16 05 75157 009
 EAC approval: RU C-IT.YT03.B.00035/19

General data

Parameter:	Value:	Page:
SIL CL acc. to EN IEC 62061	up to SIL CL 3	
Performance Level (PL) acc. to EN ISO 13849-1	up to PL e	
Safety category acc. to EN ISO 13849-1	up to cat. 4	
MTTF _D	431	
PFH _D	7.08E-09	
Mission time	20 years	
System response time	< 30 ms	
Dimensions (HxLxW)	111.5x45x99 mm	
Housing data		303 part 1
Environmental data		303 part 2
Supply		303 part 3
In compliance with standards		303 part 4
Programming software	Gemis Studio	303 part 5
USB port	Yes	
Safety inputs (Ix)	4	303 part 6
Inputs for 4-20 mA analogue signals (Cx)	2	303 part 8
Test outputs (Tx)	4	303 part 10
Semiconductor signalling output circuits (Ox)	4	303 part 11
Semiconductor safety output circuits (OSx)	4 PNP	303 part 12

Pin assignment

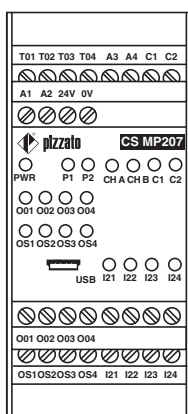

Internal block diagram

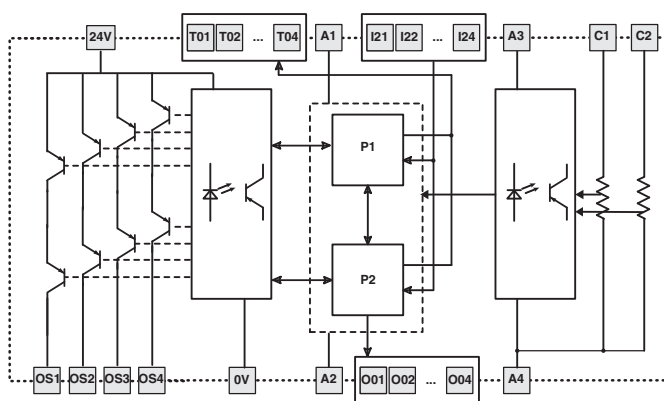

Code structure

CS MP207M0

Connection type

- M** Connector with screw terminals
- X** Connector with spring terminals



Main features

- For safety applications up to SIL CL 3/PL e
- Supply voltage: 24 Vdc
- Gemnis Studio for easy and intuitive programming and program simulation
- Large selection of logical blocks for the management of external devices and programs
- Custom configured versions available on request

General data

Parameter:	Value:	Page:
SIL CL acc. to EN IEC 62061	up to SIL CL 3	
Performance Level (PL) acc. to EN ISO 13849-1	up to PL e	
Safety category acc. to EN ISO 13849-1	up to cat. 4	
MTTF _D	633	
PFH _D	7.02E-09	
Mission time	20 years	
System response time	< 30 ms	
Dimensions (HxLxW)	111.5x45x99 mm	
Housing data		303 part 1
Environmental data		303 part 2
Supply		303 part 3
In compliance with standards		303 part 4
Programming software	Gemis Studio	303 part 5
USB port	Yes	
Safety inputs (Ix)	16	303 part 6
Test outputs (Tx)	4	303 part 10
Semiconductor safety output circuits (OSx)	8 PNP	303 part 13

Quality marks:



EC type examination certificate: M6A 16 06 75157 010
 UL approval: E131787
 CCC approval: 2013010305640211
 TÜV SÜD approval: Z10 16 05 75157 009
 EAC approval: RU C-IT.YT03.B.00035/19

Pin assignment

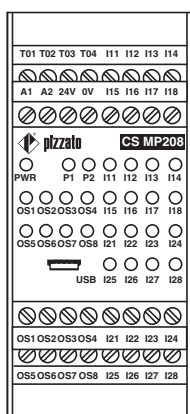

Internal block diagram

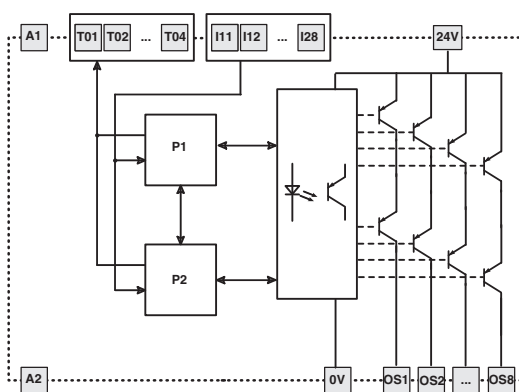

Code structure

CS MP208M0

Connection type

- M** Connector with screw terminals
- X** Connector with spring terminals

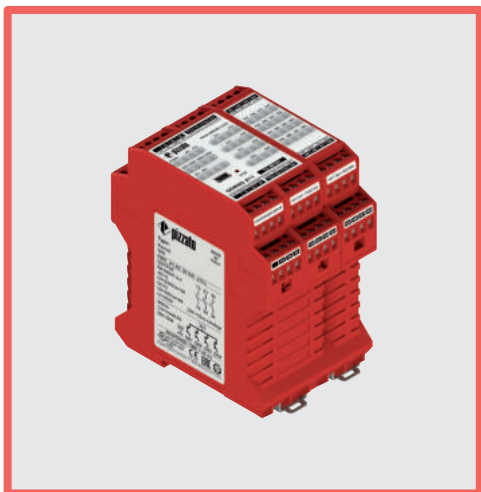

Main features

- For safety applications up to SIL CL 3/PL e
- Supply voltage: 24 Vdc
- Gemnis Studio for easy and intuitive programming and program simulation
- Large selection of logical blocks for the management of external devices and programs
- Custom configured versions available on request

General data

Parameter:	Value:	Page:
SIL CL acc. to EN IEC 62061	up to SIL CL 3	
Performance Level (PL) acc. to EN ISO 13849-1	up to PL e	
Safety category acc. to EN ISO 13849-1	up to cat. 4	
MTTF _D	128	
PFH _D	1.88E-09	
Mission time	20 years	
System response time	< 40 ms	
Dimensions (HxLxW)	111.5x67.5x99 mm	
Housing data		303 part 1
Environmental data		303 part 2
Supply		303 part 3
In compliance with standards		303 part 4
Programming software	Gemis Studio	303 part 5
USB port	Yes	
Safety inputs (Ix)	24	303 part 6
Test outputs (Tx)	8	303 part 10
Semiconductor signalling output circuits (Ox)	4	303 part 11
Safety relay circuits	3NO	303 part 14

Quality marks:



EC type examination certificate: M6A 16 06 75157 010
 UL approval: E131787
 CCC approval: 2013010305640211
 TÜV SÜD approval: Z10 16 05 75157 009
 EAC approval: RU C-IT.YT03.B.00035/19

Pin assignment

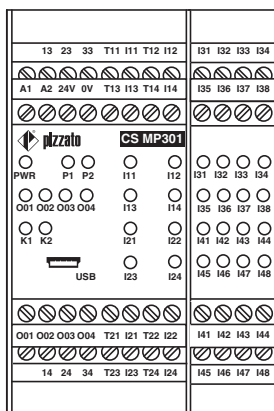

Internal block diagram

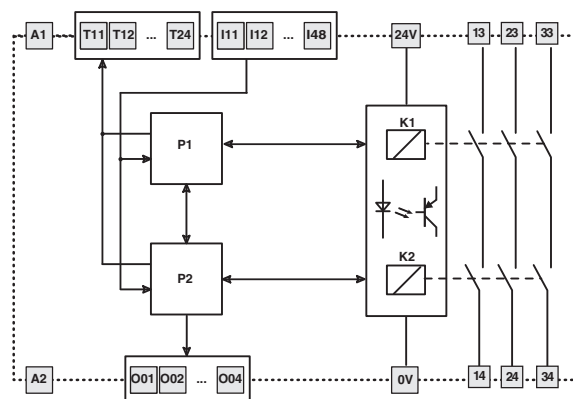

Code structure

CS MP301M0

Connection type

- M** Connector with screw terminals
- X** Connector with spring terminals

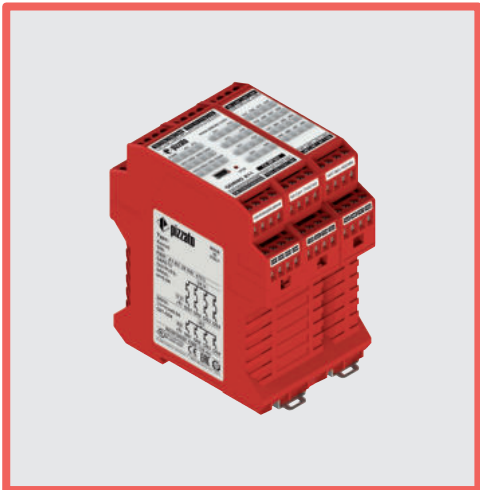

Main features

- For safety applications up to SIL CL 3/PL e
- Supply voltage: 24 Vdc
- Gemnis Studio for easy and intuitive programming and program simulation
- Large selection of logical blocks for the management of external devices and programs
- Custom configured versions available on request

General data

Parameter:	Value:	Page:
SIL CL acc. to EN IEC 62061	up to SIL CL 3	
Performance Level (PL) acc. to EN ISO 13849-1	up to PL e	
Safety category acc. to EN ISO 13849-1	up to cat. 4	
MTTF _D	535	
PFH _D	1.57E-09	
Mission time	20 years	
System response time	< 30 ms	
Dimensions (HxLxW)	111.5x67.5x99 mm	
Housing data		303 part 1
Environmental data		303 part 2
Supply		303 part 3
In compliance with standards		303 part 4
Programming software	Gemis Studio	303 part 5
USB port	Yes	
Safety inputs (Ix)	24	303 part 6
Test outputs (Tx)	12	303 part 10
Semiconductor signalling output circuits (Ox)	4	303 part 11
Semiconductor safety output circuits (OSx)	4 PNP	303 part 12

Quality marks:



EC type examination certificate: M6A 16 06 75157 010
 UL approval: E131787
 CCC approval: 2013010305640211
 TÜV SÜD approval: Z10 16 05 75157 009
 EAC approval: RU C-IT.YT03.B.00035/19

Pin assignment

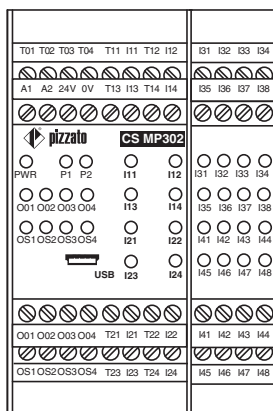

Internal block diagram

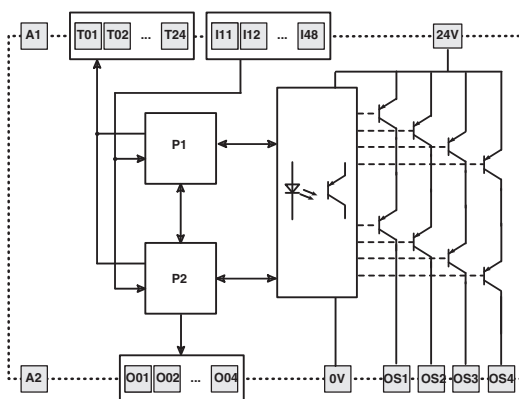

Code structure

CS MP302M0

Connection type

- M** Connector with screw terminals
- X** Connector with spring terminals



Main features

- For safety applications up to SIL CL 3/PL e
- Supply voltage: 24 Vdc
- Gemnis Studio for easy and intuitive programming and program simulation
- Large selection of logical blocks for the management of external devices and programs
- Custom configured versions available on request

General data

Parameter:	Value:	Page:
SIL CL acc. to EN IEC 62061	up to SIL CL 3	
Performance Level (PL) acc. to EN ISO 13849-1	up to PL e	
Safety category acc. to EN ISO 13849-1	up to cat. 4	
MTTF _D	485	
PFH _D	1.76E-09	
Mission time	20 years	
System response time	< 30 ms	
Dimensions (HxLxW)	111.5x67.5x99 mm	
Housing data		303 part 1
Environmental data		303 part 2
Supply		303 part 3
In compliance with standards		303 part 4
Programming software	Gemis Studio	303 part 5
USB port	Yes	
Safety inputs (Ix)	32	303 part 6
Test outputs (Tx)	4	303 part 10
Semiconductor signalling output circuits (Ox)	4	303 part 11
Semiconductor safety output circuits (OSx)	4 PNP	303 part 12

Quality marks:



EC type examination certificate: M6A 16 06 75157 010
 UL approval: E131787
 CCC approval: 2013010305640211
 TÜV SÜD approval: Z10 16 05 75157 009
 EAC approval: RU C-IT.YT03.B.00035/19

Pin assignment

T01 T02 T03 T04	I11 I12 I13 I14	I31 I32 I33 I34
A1 A2 24V 0V	I15 I16 I17 I18	I35 I36 I37 I38
PWR P1 P2	I11 I12 I13 I14	I31 I32 I33 I34
O01 O02 O03 O04	I15 I16 I17 I18	I35 I36 I37 I38
OS1 OS2 OS3 OS4	I21 I22 I23 I24	I41 I42 I43 I44
USB	I25 I26 I27 I28	I45 I46 I47 I48
O01 O02 O03 O04	I21 I22 I23 I24	I41 I42 I43 I44
OS1 OS2 OS3 OS4	I25 I26 I27 I28	I45 I46 I47 I48

Internal block diagram

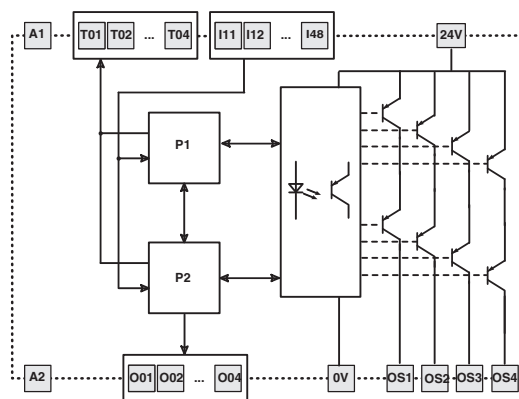

Code structure

CS MP303M0

Connection type

- M** Connector with screw terminals
- X** Connector with spring terminals

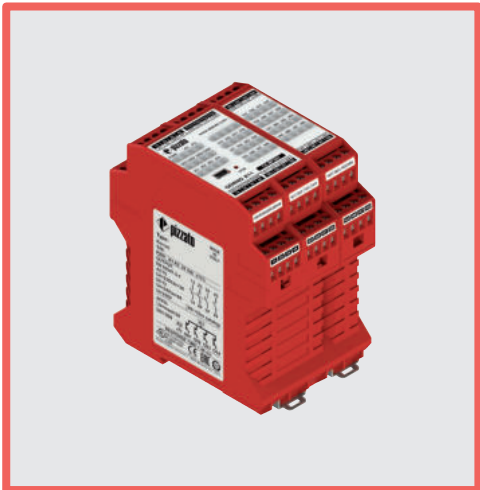

Main features

- For safety applications up to SIL CL 3/PL e
- Supply voltage: 24 Vdc
- Gemnis Studio for easy and intuitive programming and program simulation
- Large selection of logical blocks for the management of external devices and programs
- Custom configured versions available on request

General data

Parameter:	Value:	Page:
SIL CL acc. to EN IEC 62061	up to SIL CL 3	
Performance Level (PL) acc. to EN ISO 13849-1	up to PL e	
Safety category acc. to EN ISO 13849-1	up to cat. 4	
MTTF _D	98	
PFH _D	2.05E-09	
Mission time	20 years	
System response time	< 40 ms	
Dimensions (HxLxW)	111.5x67.5x99 mm	
Housing data		303 part 1
Environmental data		303 part 2
Supply		303 part 3
In compliance with standards		303 part 4
Programming software	Gemis Studio	303 part 5
USB port	Yes	
Safety inputs (Ix)	28	303 part 6
Test outputs (Tx)	4	303 part 10
Semiconductor signalling output circuits (Ox)	4	303 part 11
Safety relay circuits	3NO+1NO	303 part 14

Quality marks:



EC type examination certificate: M6A 16 06 75157 010
 UL approval: E131787
 CCC approval: 2013010305640211
 TÜV SÜD approval: Z10 16 05 75157 009
 EAC approval: RU C-IT.YT03.B.00035/19

Pin assignment

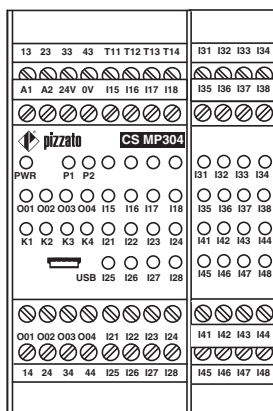

Internal block diagram

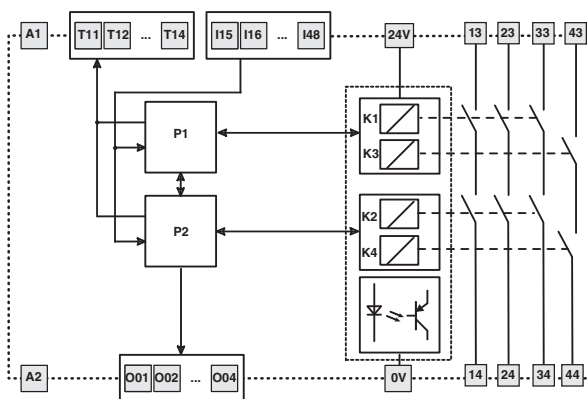

Code structure

CS MP304M0

Connection type

- M** Connector with screw terminals
- X** Connector with spring terminals



Main features

- For safety applications up to SIL CL 3/PL e
- Supply voltage: 24 Vdc
- Gemnis Studio for easy and intuitive programming and program simulation
- Large selection of logical blocks for the management of external devices and programs
- Custom configured versions available on request

General data

Parameter:	Value:	Page:
SIL CL acc. to EN IEC 62061	up to SIL CL 3	
Performance Level (PL) acc. to EN ISO 13849-1	up to PL e	
Safety category acc. to EN ISO 13849-1	up to cat. 4	
MTTF _D	535	
PFH _D	1.57E-09	
Mission time	20 years	
System response time	< 30 ms	
Dimensions (HxLxW)	111.5x67.5x99 mm	
Housing data		303 part 1
Environmental data		303 part 2
Supply		303 part 3
In compliance with standards		303 part 4
Programming software	Gemis Studio	303 part 5
USB port	Yes	
Safety inputs (Ix)	24	303 part 6
Test outputs (Tx)	4	303 part 10
Semiconductor signalling output circuits (Ox)	12	303 part 11
Semiconductor safety output circuits (OSx)	4 PNP	303 part 12

Quality marks:



EC type examination certificate: M6A 16 06 75157 010
 UL approval: E131787
 CCC approval: 2013010305640211
 TÜV SÜD approval: Z10 16 05 75157 009
 EAC approval: RU C-IT.YT03.B.00035/19

Pin assignment

T01 T02 T03 T04	I11 I12 I13 I14	I31 I32 I33 I34
A1 A2 24V 0V	I15 I16 I17 I18	I35 I36 I37 I38
CS MP305		
PWR P1 P2	I11 I12 I13 I14	I31 I32 I33 I34
O01 O02 O03 O04	I15 I16 I17 I18	I35 I36 I37 I38
OS1 OS2 OS3 OS4	I21 I22 I23 I24	O41 O42 O43 O44
USB	I25 I26 I27 I28	O45 O46 O47 O48
O01 O02 O03 O04	I21 I22 I23 I24	O41 O42 O43 O44
OS1 OS2 OS3 OS4	I25 I26 I27 I28	O45 O46 O47 O48

Internal block diagram

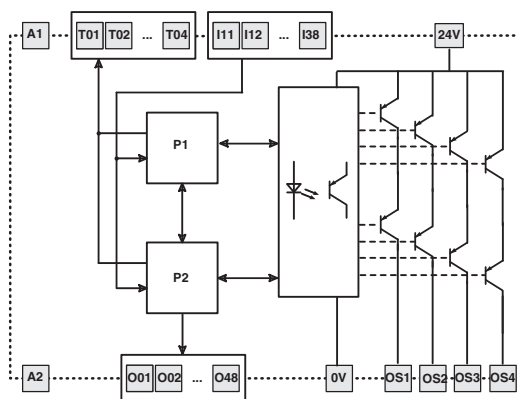

Code structure

CS MP305M0

Connection type

- M** Connector with screw terminals
- X** Connector with spring terminals

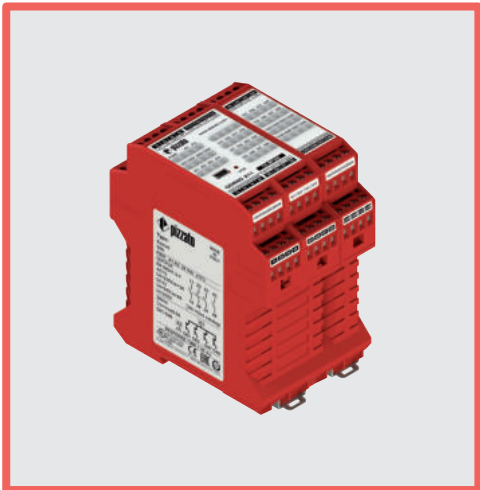

Main features

- For safety applications up to SIL CL 3/PL e
- Supply voltage: 24 Vdc
- Gemnis Studio for easy and intuitive programming and program simulation
- Large selection of logical blocks for the management of external devices and programs
- Custom configured versions available on request

General data

Parameter:	Value:	Page:
SIL CL acc. to EN IEC 62061	up to SIL CL 3	
Performance Level (PL) acc. to EN ISO 13849-1	up to PL e	
Safety category acc. to EN ISO 13849-1	up to cat. 4	
MTTF _D	100	
PFH _D	1.86E-09	
Mission time	20 years	
System response time	< 40 ms	
Dimensions (HxLxW)	111.5x67.5x99 mm	
Housing data		303 part 1
Environmental data		303 part 2
Supply		303 part 3
In compliance with standards		303 part 4
Programming software	Gemis Studio	303 part 5
USB port	Yes	
Safety inputs (Ix)	20	303 part 6
Test outputs (Tx)	4	303 part 10
Semiconductor signalling output circuits (Ox)	12	303 part 11
Safety relay circuits	3NO+1NO	303 part 14

Quality marks:



EC type examination certificate: M6A 16 06 75157 010
 UL approval: E131787
 CCC approval: 2013010305640211
 TÜV SÜD approval: Z10 16 05 75157 009
 EAC approval: RU C-IT.YT03.B.00035/19

Pin assignment

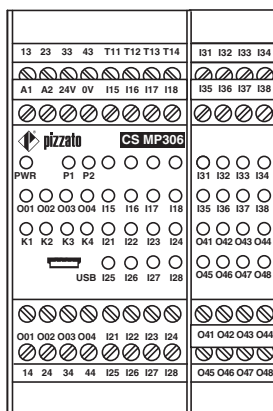

Internal block diagram

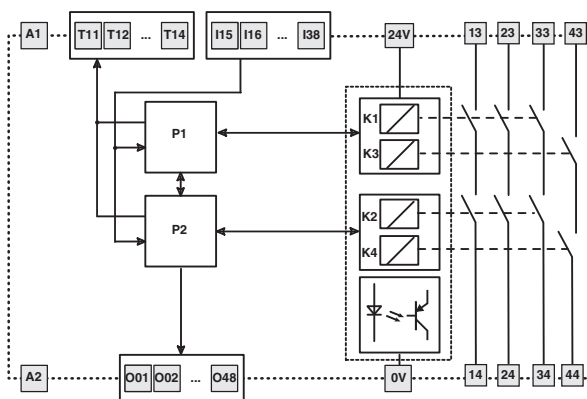

Code structure

CS MP306M0

Connection type

- M** Connector with screw terminals
- X** Connector with spring terminals



Main features

- For safety applications up to SIL CL 3/PL e
- Supply voltage: 24 Vdc
- Gemnis Studio for easy and intuitive programming and program simulation
- Large selection of logical blocks for the management of external devices and programs
- Custom configured versions available on request

Quality marks:



EC type examination certificate: M6A 16 06 75157 010
 UL approval: E131787
 CCC approval: 2013010305640211
 TÜV SÜD approval: Z10 16 05 75157 009
 EAC approval: RU C-IT.YT03.B.00035/19

General data

Parameter:	Value:	Page:
SIL CL acc. to EN IEC 62061	up to SIL CL 3	
Performance Level (PL) acc. to EN ISO 13849-1	up to PL e	
Safety category acc. to EN ISO 13849-1	up to cat. 4	
MTTF _D	289	
PFH _D	8.38E-09	
Mission time	20 years	
System response time	< 30 ms	
Dimensions (HxLxW)	111.5x67.5x99 mm	
Housing data		303 part 1
Environmental data		303 part 2
Supply		303 part 3
In compliance with standards		303 part 4
Programming software	Gemis Studio	303 part 5
USB port	Yes	
Safety inputs (Ix)	8	303 part 6
Decoupled digital inputs (Jx)	4	303 part 7
Inputs for 4-20 mA analogue signals (Cx)	2	303 part 8
Inputs for frequency signals from 0 to 4 kHz (Fx)	4	303 part 9
Test outputs (Tx)	4	303 part 10
Semiconductor signalling output circuits (Ox)	4	303 part 11
Semiconductor safety output circuits (OSx)	4 PNP	303 part 12

Pin assignment

T01 T02 T03 T04	A3 A4 A4	A5 A6 C1 C2
A1 A2 24V 0V F1A F1B F2A F2B		
PWR P1 P2	CH ACH B C1 C2	
O01 O02 O03 O04 F1A F1B F2A F2B		
O01 O02 O03 O04 I21 I22 I23 I24		
OS1 OS2 OS3 OS4 I21 I22 I23 I24		
USB J25 J26 J27 J28	I41 I42 I43 I44	
O01 O02 O03 O04 I21 I22 I23 I24		
OS1 OS2 OS3 OS4 J25 J26 J27 J28	I41 I42 I43 I44	

Internal block diagram

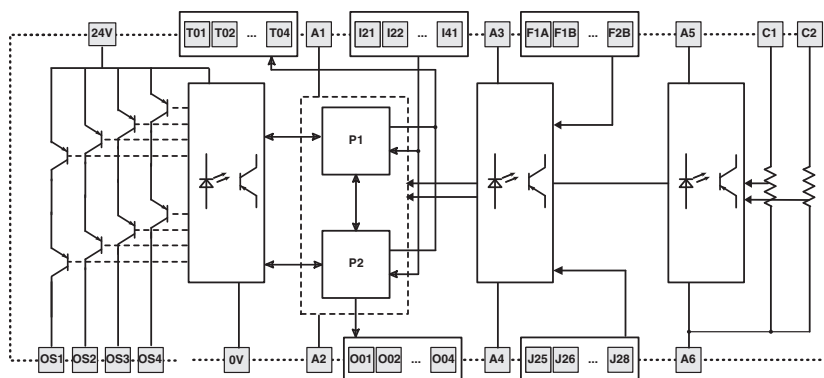

Code structure

CS MP307M0

Connection type

- M** Connector with screw terminals
- X** Connector with spring terminals

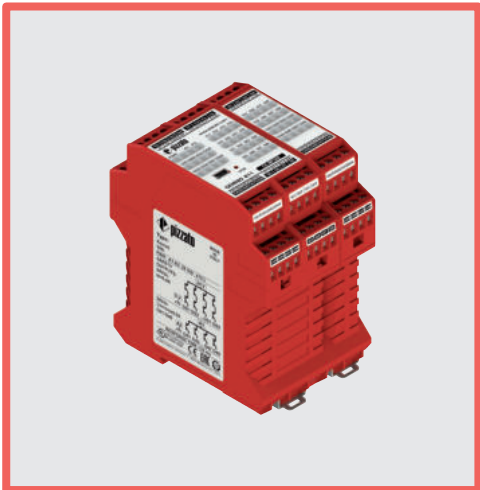

Main features

- For safety applications up to SIL CL 3/PL e
- Supply voltage: 24 Vdc
- Gemnis Studio for easy and intuitive programming and program simulation
- Large selection of logical blocks for the management of external devices and programs
- Custom configured versions available on request

General data

Parameter:	Value:	Page:
SIL CL acc. to EN IEC 62061	up to SIL CL 3	
Performance Level (PL) acc. to EN ISO 13849-1	up to PL e	
Safety category acc. to EN ISO 13849-1	up to cat. 4	
MTTF _D	548	
PFH _D	7.27E-09	
Mission time	20 years	
System response time	< 30 ms	
Dimensions (HxLxW)	111.5x67.5x99 mm	
Housing data		303 part 1
Environmental data		303 part 2
Supply		303 part 3
In compliance with standards		303 part 4
Programming software	Gemis Studio	303 part 5
USB port	Yes	
Safety inputs (Ix)	24	303 part 6
Test outputs (Tx)	4	303 part 10
Semiconductor signalling output circuits (Ox)	8	303 part 11
Semiconductor safety output circuits (OSx)	8 PNP	303 part 13

Quality marks:



EC type examination certificate: M6A 16 06 75157 010
 UL approval: E131787
 CCC approval: 2013010305640211
 TÜV SÜD approval: Z10 16 05 75157 009
 EAC approval: RU C-IT.YT03.B.00035/19

Pin assignment

T01 T02 T03 T04	I11 I12 I13 I14	I31 I32 I33 I34
A1 A2 24V 0V	I15 I16 I17 I18	I35 I36 I37 I38
pizzato CS MP308		
PWR P1 P2	I11 I12 I13 I14	I31 I32 I33 I34
OS1 OS2 OS3 OS4	I15 I16 I17 I18	I35 I36 I37 I38
OS5 OS6 OS7 OS8	I21 I22 I23 I24	O41 O42 O43 O44
USB	I25 I26 I27 I28	O45 O46 O47 O48
OS1 OS2 OS3 OS4	I21 I22 I23 I24	O41 O42 O43 O44
OS5 OS6 OS7 OS8	I25 I26 I27 I28	O45 O46 O47 O48

Internal block diagram

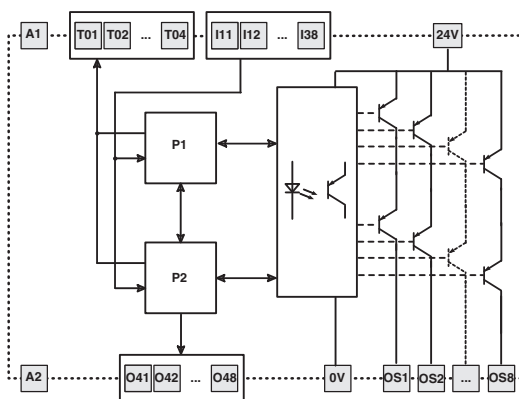

Code structure

CS MP308M0

Connection type

- M** Connector with screw terminals
- X** Connector with spring terminals

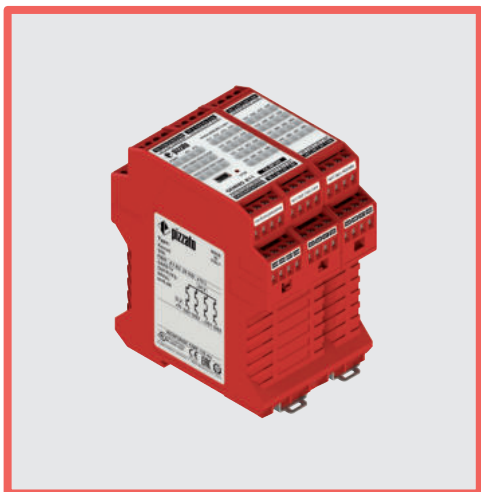

Main features

- For safety applications up to SIL CL 3/PL e
- Supply voltage: 24 Vdc
- Gemnis Studio for easy and intuitive programming and program simulation
- Large selection of logical blocks for the management of external devices and programs
- Custom configured versions available on request

Quality marks:



EC type examination certificate: M6A 16 06 75157 010
 UL approval: E131787
 CCC approval: 2013010305640211
 TÜV SÜD approval: Z10 16 05 75157 009
 EAC approval: RU C-IT.YT03.B.00035/19

General data

Parameter:	Value:	Page:
SIL CL acc. to EN IEC 62061	up to SIL CL 3	
Performance Level (PL) acc. to EN ISO 13849-1	up to PL e	
Safety category acc. to EN ISO 13849-1	up to cat. 4	
MTTF _D	496	
PFH _D	7.46E-09	
Mission time	20 years	
Mission time	20 years	
System response time	< 30 ms	
Dimensions (HxLxW)	111.5x67.5x99 mm	
Housing data		303 part 1
Environmental data		303 part 2
Supply		303 part 3
In compliance with standards		303 part 4
Programming software	Gemis Studio	303 part 5
USB port	Yes	
Safety inputs (Ix)	32	303 part 6
Test outputs (Tx)	4	303 part 10
Semiconductor safety output circuits (OSx)	8 PNP	303 part 13

Pin assignment

T01 T02 T03 T04	I11 I12 I13 I14	I31 I32 I33 I34
A1 A2 24V 0V	I15 I16 I17 I18	I35 I36 I37 I38
pizzato CS MP309		
PWR P1 P2	I11 I12 I13 I14	I31 I32 I33 I34
OS1 OS2 OS3 OS4	I15 I16 I17 I18	I35 I36 I37 I38
OS5 OS6 OS7 OS8	I21 I22 I23 I24	I41 I42 I43 I44
USB	I25 I26 I27 I28	I45 I46 I47 I48
OS1 OS2 OS3 OS4	I21 I22 I23 I24	I41 I42 I43 I44
OS5 OS6 OS7 OS8	I25 I26 I27 I28	I45 I46 I47 I48

Internal block diagram

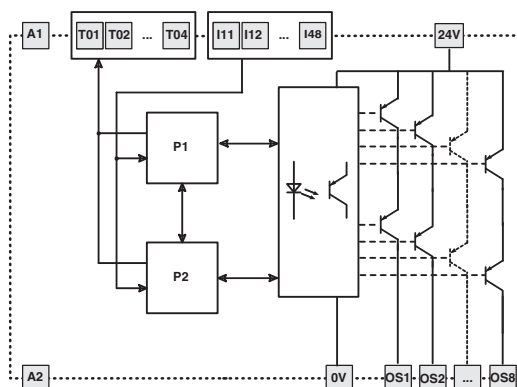

Code structure

CS MP309M0

Connection type

- M** Connector with screw terminals
- X** Connector with spring terminals

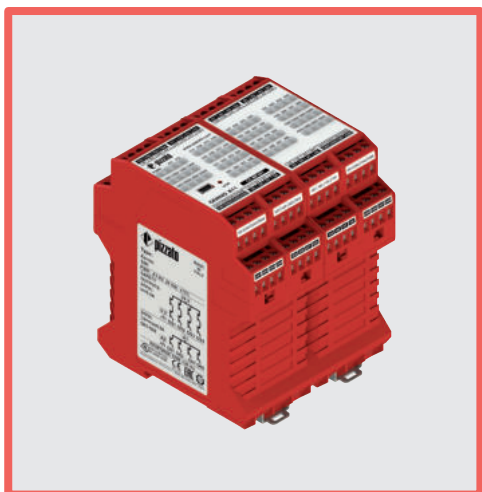

Main features

- For safety applications up to SIL CL 3/PL e
- Supply voltage: 24 Vdc
- Gemnis Studio for easy and intuitive programming and program simulation
- Large selection of logical blocks for the management of external devices and programs
- Custom configured versions available on request

Quality marks:



EC type examination certificate: M6A 16 06 75157 010
 UL approval: E131787
 CCC approval: 2013010305640211
 TÜV SÜD approval: Z10 16 05 75157 009
 EAC approval: RU C-IT.YT03.B.00035/19

General data

Parameter:	Value:	Page:
SIL CL acc. to EN IEC 62061	up to SIL CL 3	
Performance Level (PL) acc. to EN ISO 13849-1	up to PL e	
Safety category acc. to EN ISO 13849-1	up to cat. 4	
MTTF _D	434	
PFH _D	1.73E-09	
Mission time	20 years	
System response time	< 30 ms	
Dimensions (HxLxW)	111.5x90x99 mm	
Housing data		303 part 1
Environmental data		303 part 2
Supply		303 part 3
In compliance with standards		303 part 4
Programming software	Gemis Studio	303 part 5
USB port	Yes	
Safety inputs (Ix)	40	303 part 6
Test outputs (Tx)	4	303 part 10
Semiconductor signalling output circuits (Ox)	12	303 part 11
Semiconductor safety output circuits (OSx)	4 PNP	303 part 12

Pin assignment

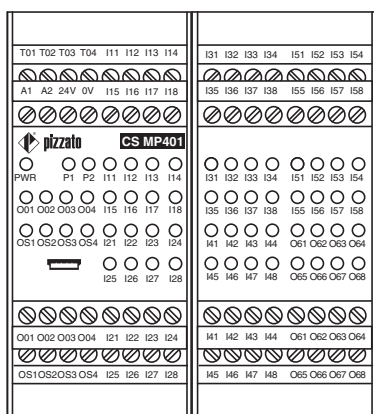

Internal block diagram

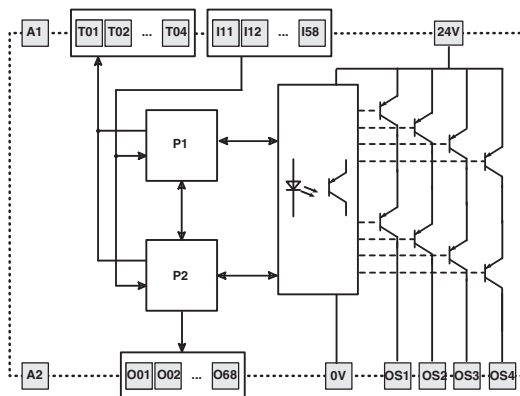

Code structure

CS MP401M0

Connection type

- M** Connector with screw terminals
- X** Connector with spring terminals

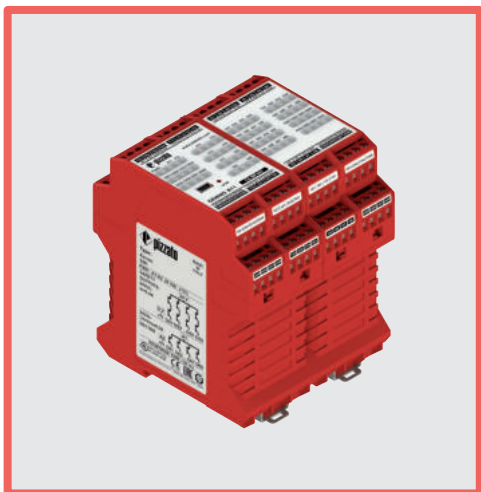

Main features

- For safety applications up to SIL CL 3/PL e
- Supply voltage: 24 Vdc
- Gemnis Studio for easy and intuitive programming and program simulation
- Large selection of logical blocks for the management of external devices and programs
- Custom configured versions available on request

General data

Parameter:	Value:	Page:
SIL CL acc. to EN IEC 62061	up to SIL CL 3	
Performance Level (PL) acc. to EN ISO 13849-1	up to PL e	
Safety category acc. to EN ISO 13849-1	up to cat. 4	
MTTF _D	478	
PFH _D	7.24E-09	
Mission time	20 years	
System response time	< 30 ms	
Dimensions (HxLxW)	111.5x90x99 mm	
Housing data		303 part 1
Environmental data		303 part 2
Supply		303 part 3
In compliance with standards		303 part 4
Programming software	Gemis Studio	303 part 5
USB port	Yes	
Safety inputs (Ix)	32	303 part 6
Test outputs (Tx)	12	303 part 10
Semiconductor signalling output circuits (Ox)	8	303 part 11
Semiconductor safety output circuits (OSx)	8 PNP	303 part 13

Quality marks:



EC type examination certificate: M6A 16 06 75157 010
 UL approval: E131787
 CCC approval: 2013010305640211
 TÜV SÜD approval: Z10 16 05 75157 009
 EAC approval: RU C-IT.YT03.B.00035/19

Pin assignment

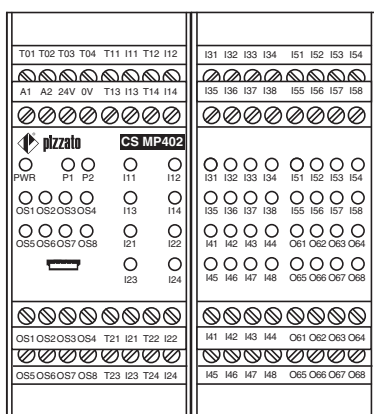

Internal block diagram

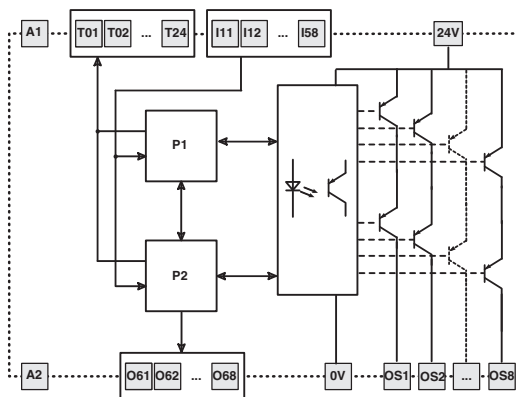

Code structure

CS MP402M0

Connection type

- M** Connector with screw terminals
- X** Connector with spring terminals

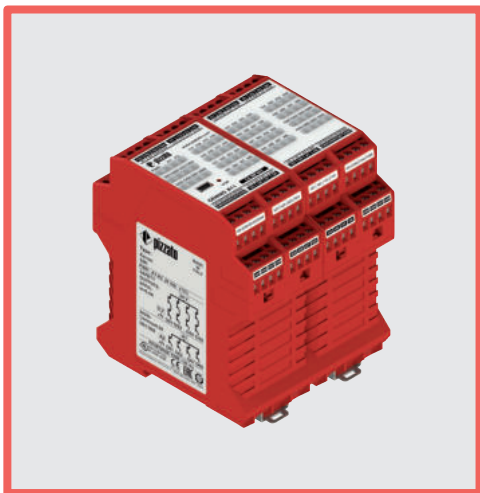

Main features

- For safety applications up to SIL CL 3/PL e
- Supply voltage: 24 Vdc
- Gemnis Studio for easy and intuitive programming and program simulation
- Large selection of logical blocks for the management of external devices and programs
- Custom configured versions available on request

General data

Parameter:	Value:	Page:
SIL CL acc. to EN IEC 62061	up to SIL CL 3	
Performance Level (PL) acc. to EN ISO 13849-1	up to PL e	
Safety category acc. to EN ISO 13849-1	up to cat. 4	
MTTF _D	438	
PFH _D	7.42E-09	
Mission time	20 years	
System response time	< 30 ms	
Dimensions (HxLxW)	111.5x90x99 mm	
Housing data		303 part 1
Environmental data		303 part 2
Supply		303 part 3
In compliance with standards		303 part 4
Programming software	Gemis Studio	303 part 5
USB port	Yes	
Safety inputs (Ix)	40	303 part 6
Test outputs (Tx)	4	303 part 10
Semiconductor signalling output circuits (Ox)	8	303 part 11
Semiconductor safety output circuits (OSx)	8 PNP	303 part 13

Quality marks:



EC type examination certificate: M6A 16 06 75157 010
 UL approval: E131787
 CCC approval: 2013010305640211
 TÜV SÜD approval: Z10 16 05 75157 009
 EAC approval: RU C-IT.YT03.B.00035/19

Pin assignment

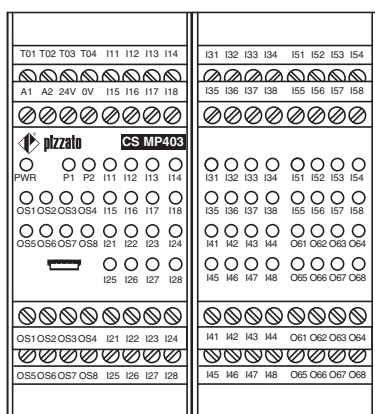

Internal block diagram

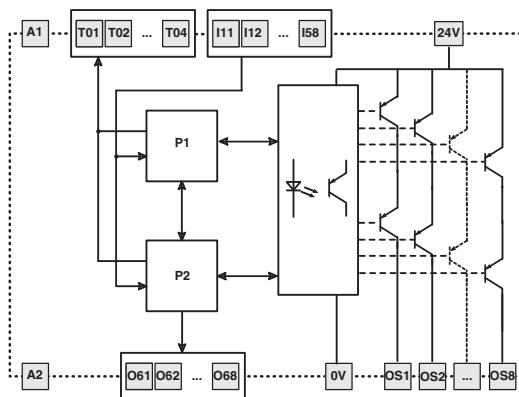

Code structure

CS MP403M0

Connection type

- M** Connector with screw terminals
- X** Connector with spring terminals

Technical data

1) Housing

Housing:	polyamide PA 6.6, self-extinguishing V0 acc. to UL 94
Protection degree:	IP40 (housing) IP20 (terminal strip)
Dimensions, cable cross sections, terminal tightening torque:	page 317, design C/E

2) Environmental

Operating temperature:	0°C ... +55°C
Storage temperature:	-20°C ... +70°C
Pollution degree:	external 3, internal 2
Overvoltage category:	II

3) Power supply

Rated voltage A1-A2 (U_n):	24 Vdc
Max. DC residual ripple in DC:	10%
Supply voltage tolerance:	$\pm 15\%$ of U_n
Rated consumption (w/o load):	< 3 W
Protection against short circuits:	PTC resistance, $I_h=0.5$ A
PTC response time:	Response time > 100 ms, release time > 3 s

Internal protection against short circuits on outputs (Tx, Ox): Electronic

Maximum current output of the module as the total current of the Ox and Tx outputs:	0.5 A
Self-test duration on startup:	< 2 s

4) Compliance with standards

EN 60947-1, EN 60947-5-1, EN 60204-1, EN ISO 13849-1, EN ISO 13855, EN 1037, EN ISO 12100, EN ISO 13850, EN 60529, EN 61000-6-2, EN 61000-6-3, EN 61326-1, EN 61326-3-1, EN 60664-1, EN 62061, EN 50581, UL 508, CSA C22.2 n° 14-95, GB/T14048.5-2017

Compliance with the requirements of:

Machinery Directive 2006/42/EC, EMC Directive 2014/30/EU, RoHS Directive 2011/65/EU.

Features approved by UL

Electrical ratings:	
Input:	4-48 inputs rated 24 V dc, 5 mA
Relay output:	230/240 Vac, 4 A general use, C300 pilot duty
Semiconductor output (when relay is not available):	up to 4 outputs rated 24 V dc, 500 mA or up to 8 outputs rated 24 Vdc, 400 mA
Semiconductor auxiliary output:	up to 32 outputs rated 24 V dc, 500 mA max
Auxiliary analogic outputs:	up to 4 rated 24 V dc, 20 mA max

Notes:

- Use 60 or 75°C copper (Cu) conductor and wire size No. 30-12 AWG, stranded or solid.
- The terminal tightening torque of 5-7 lb in.
- Only for 24 Vac/dc versions: supply from remote Class 2 source or limited voltage limited energy.

Features approved by TÜV SÜD

Rated supply voltage U_n :	24 Vdc (-15% ... +15%)
Ambient temperature:	0°C ... +55°C
Response time:	< 30 ms < 40 ms for versions with relay outputs

In compliance with standards: EN ISO 13849-1:2015 (Cat.4, PL e), EN 61508-1:2010 (SIL 3), EN 61508-2:2010 (SIL 3), EN 61508-3:2010 (SIL 3), EN 61508-4:2010 (SIL 3), EN 62061:2005/A1:2013/A2:2015 (SIL CL 3)

5) Gemnis Studio

The **Gemis Studio** software is the graphic development environment for the creation, simulation and debugging of programs designed for upload to Gemnis line modules.

The software is licensed to users wishing to program these modules, subject to prior registration at www.gemis.com.

From our website you can download the latest version of the software, which allows you to program the safety modules of the Gemnis family.

Gemis Studio software minimum download requirements

Computer and processor:	X86 with clock frequency of 1 GHz
Memory:	512 MB
Hard disk:	200 MB
Monitor:	Monitor with 1024x768 resolution or higher
Operating system:	Microsoft Windows 7 or Microsoft Windows 10 Microsoft Framework .NET 3.5 or higher Microsoft Report Viewer Acrobat Reader

6) Input circuits (Ix)

Voltage and current in the input circuits:	24 V, 5 mA
Input signals:	0-8 V (Off), 12-24 V (On)
Galvanic separation:	No
Minimum duration of input signal:	10 ms
Input signal filtering:	Yes, maximum interference period 0.4 ms
Maximum input resistance:	100 Ω
Maximum input capacitance:	470 nF to ground 470 nF between two conductors

7) Decoupled input circuits (Jx)

Voltage and current in the input circuits:	24 V, 5 mA
Input signals:	0-8 V (Off), 12-24 V (On)
Galvanic separation:	Yes
Insulation voltage (U_i):	500 V
Minimum duration of input signal:	10 ms
Input signal filtering:	Yes, maximum interference period 0.4 ms
Maximum input resistance:	100 Ω
Maximum input capacitance:	470 nF to ground 470 nF between two conductors

NB: Voltage and current values indicated refer to the power supply terminals (Ax, see each module individually) of the board where the Jx type terminals are present

8) Analogue input circuits (Cx)

Rated supply voltage:	24 Vdc $\pm 15\%$
Analogue input type:	4-20 mA current loop
Measurement range:	0 ... 25 mA
Accuracy over entire measurement range:	1 % ± 1 digit
Resolution:	0.01 mA
Input resistance:	100 Ohm
Maximum applicable current:	30 mA
Managed sensors:	"source" type with 2/3 wires
Galvanic separation:	Yes
Insulation voltage (U_i):	500 V

NB: Voltage and current values indicated refer to the power supply terminals (Ax, see each module individually) of the board where the Cx type terminals are present

**9) Frequency input circuits (Fx)**

Rated supply voltage:	24 Vdc \pm 15 %
Input circuit voltage and current:	24 Vdc, 7 mA
Check of the supply voltage of the connected proximity sensors:	24 Vdc \pm 20%
Maximum detectable frequency:	4 kHz
Minimum detectable frequency:	1 Hz
Frequency detection accuracy:	1 % \pm 1 digit
Resolution:	0.1 Hz
Minimum time for standstill detection:	1 s
Galvanic separation:	Yes
Insulation voltage (U _i):	500 V

NB: Voltage and current values indicated refer to the power supply terminals (Ax, see each module individually) of the board where the Fx type terminals are present

10) Circuits with Test signals (Tx)

Signal type:	Pulsed 100 Hz 24V/0V, duty cycle 50%
Max. total current:	See Supply
Protected against short circuit:	Yes

11) Semiconductor signalling output circuits (Ox)

Output type:	PNP
Maximum current per output:	0.5 A
Max. total current:	see Supply
Impulse withstand voltage (U _{imp}):	0.8 kV
Rated insulation voltage (U _i):	32 V
Protected against short circuit:	Yes
Galvanic separation:	No

12) Semiconductor safety output circuits (OSx) with 4 safety outputs

Rated voltage 24V-0V:	24 Vdc
Number of outputs:	4
Output type:	PNP
Maximum current per output:	0.5 A
Max. total output current:	2 A
Minimum current:	10 mA
Maximum capacitive load to ground per output:	400 nF
Maximum inductive load per output:	500 mH
Protection fuse:	2 A type gG
Galvanic separation:	Yes
Impulse withstand voltage (U _{imp}):	0.8 kV
Rated insulation voltage (U _i):	32 V
Short circuit detection between outputs:	Yes
Duration of the deactivation impulses at the safety outputs:	< 300 μ s

13) Semiconductor safety output circuits (OSx) with 8 safety outputs

Rated voltage 24V-0V:	24 Vdc
Number of outputs:	8
Output type:	PNP
Maximum current per output:	0.4 A
Max. total output current:	3 A
Minimum current:	10 mA
Maximum capacitive load to ground per output:	400 nF
Maximum inductive load per output:	500 mH
Protection fuse:	4 A type gG

Galvanic separation:	Yes
Impulse withstand voltage (U _{imp}):	0.8 kV
Rated insulation voltage (U _i):	32 V
Short circuit detection between outputs:	Yes
Duration of the deactivation impulses at the safety outputs:	< 300 μ s

14) Safety relay circuits

Rated voltage 24V-0V:	24 Vdc
Contact type:	Forcibly guided contacts acc. to EN 50205
Material of the contacts:	gold-plated silver alloy
Maximum switching voltage:	230 Vac; 300 Vdc
Maximum current per contact:	6 A
Max. total current ΣI_{th2} :	36 A ²
Minimum current:	10 mA
Protection fuse:	4 A type gG
Maximum load:	1380 VA/W
Impulse withstand voltage (U _{imp}):	4 kV
Rated insulation voltage (U _i):	500 V
Utilization category (EN 60947-5-1):	AC15 (U _e =230V, I _e =3A); DC13 (U _e =24V, I _e =4A) (6 op. cycl./min.)
Utilization category (UL 508):	C300
Contact resistance:	< 100 m Ω
Mechanical endurance:	>10 million operating cycles
Electrical endurance:	>100,000 operating cycles
Galvanic separation:	Yes

The number and the load capacity of output contacts can be increased by using expansion modules or contactors.

See page 263-272.