



**SPRINT ELECTRIC**

**Part 3 High Power Modules  
PL / PLX 275 - 980**

**Part 1  
PL / PLX  
Digital DC Drive**

**Part 2  
Application Blocks**

**Part 3  
High Power Modules  
PL / PLX 275 - 980**





This manual should be read in conjunction with the PL / PLX Digital DC Drive Manual. (Part 1)  
**Important.** See section 2 in main PL / PLX Digital DC Drive Manual for **WARNINGS**

## 1 Table of contents

1	Table of contents.....	1
2	Introduction .....	2
3	Rating Table.....	2
4	Mechanical Dimensions PL/X 275 - 440.....	3
5	Mechanical Dimensions PL/X 520 - 980.....	4
6	Venting.....	5
6.1	General venting information.....	5
6.1.1	When venting kit impractical. Models PL/X 275/315/360/520/600.....	5
6.1.2	When venting kit impractical. Models PL/X 400/440/700/800/900/980.....	5
6.2	Venting kit for PL/X 275 - 440.....	5
6.2.1	PL/X 275 - 440 venting kit diagram.....	6
6.3	Venting kit for PL/X 520 - 980.....	6
6.4	Air supply to enclosure .....	7
6.5	Exhaust air .....	7
6.6	Venting summary .....	7
6.6.1	Diagram of air flow .....	8
7	Product rating table .....	9
7.1	Product rating labels .....	9
7.2	Semiconductor fuses.....	10
7.2.1	PL and PLX Models AC and DC semiconductor fuses .....	10
7.2.2	PLX Models DC semi-conductor fuses .....	11
7.3	Terminal information.....	11
7.3.1	Control Terminals .....	11
7.3.2	Powerboard Terminals .....	11
7.3.3	Terminal tightening torques .....	11
7.3.4	Forces applied to the power terminals.....	11
7.3.5	Avoid dropping small objects into unit.....	12
7.4	Line reactors .....	13
7.5	Lifting the unit.....	13
7.5.1	Unit weight.....	13

## 2 Introduction

These additional models have all the functionality as described in the **PL / PLX Digital DC Drive Product Manual**. They also have the option of being supplied as MV units that are able to accept AC supply voltages up to 600 Volts and HV units that are able to accept AC supply voltages up to 690 Volts for motors with armatures of 750V DC. They are available with the power 3 phase supply terminals in standard top entry, or bottom entry as an option.

## 3 Rating Table

Nominal maximum continuous shaft ratings

Model	kW at 460V olt	HP at 460V olt	HP at 500V	HP at 750V (690V AC) HV models	100% Armature Current DC Amps	100% Field Amps	Dimensions mm  W x H x D
PL 2 quadrant PLX 4 quadrant Suffix MV for 600 VAC Suffix HV for 690 VAC Suffix BE for bottom entry 3 phase power							
PL and PLX	275	275	370	400	600	650	32 or 50 253 x 700 x 350
PL and PLX	315	315	425	460	690	750	32 or 50 253 x 700 x 350
PL and PLX	360	360	485	520	780	850	32 or 50 253 x 700 x 350
PL* and PLX	400	400	540	580	875	950	32 or 50 253 x 700 x 350
PL* <sup>c</sup> and PLX <sup>c</sup>	440	440	590	640	970	1050	32 or 50 253 x 700 x 350
PL and PLX	520	520	700	760	1140	1250	64 506 x 700 x 350
PL and PLX	600	600	810	880	1320	1450	64 506 x 700 x 350
PL* and PLX	700	700	940	1020	1530	1650	64 506 x 700 x 350
PL* and PLX	800	800	1080	1170	1760	1850	64 506 x 700 x 350
PL* and PLX	900	800	1200	1300	1950	2050	64 506 x 700 x 350
PL* <sup>c</sup> and PLX <sup>c</sup>	980	980	1320	1430	2145	2250	64 506 x 700 x 350

\* Starred models: (PL\*) 2 Q models have electronic regen stopping. PL/X<sup>c</sup> Models have no overload capability.

### Standard Models

Main 3 phase supply 50 - 60hz  
Auxiliary 3 phase supply 50 - 60hz  
Control 1 phase (50VA) 50 - 60Hz

Any supply from 12 to 500V AC nominal +/- 10% (CE)  
Any supply from 100 to 500V AC nominal +/- 10% (CE)  
Any supply from 110 to 240V AC +/- 10%

### Medium Voltage (MV) Models

Main 3 phase supply 50 - 60hz  
Auxiliary 3 phase supply 50 - 60hz  
Control 1 phase (50VA) 50 - 60Hz

Any supply from 12 to 600V nominal AC +/- 10% (CE)  
Any supply from 100 to 690V nominal AC +/- 10% (CE)  
Any supply from 110 to 240V AC +/- 10%

### High Voltage (HV) Models

Main 3 phase supply 50 - 60hz  
Auxiliary 3 phase supply 50 - 60hz  
Control 1 phase (50VA) 50 - 60Hz

Any supply from 12 to 690V nominal AC +/- 10% (CE)  
Any supply from 100 to 690V nominal AC +/- 10% (CE)  
Any supply from 110 to 240V AC +/- 10%

### Internal Fan supply

PL/X 275/315/360/400/440 models also need a separate 100VA 240V 50/60Hz ac supply for the fan.  
PL/X 520/600/700/800/900/980 models also need a separate 200VA 240V 50/60Hz ac supply for the fan.

### OUTPUT VOLTAGE RANGE

Armature PLX and PL\* 0 to 1.2 times AC supply. PL 0 to 1.3 times AC supply. (Absolute upper limits)  
Note. 1.1 times AC supply is recommended if supply variations exceed -6%.  
Field 0 to 0.9 times AC supply on auxiliary terminals. (EL1, EL2, EL3)

### OUTPUT CURRENT RANGE

Armature 0 to 100% continuous. 150% for 25 seconds +/- for PLX  
Field programmable minimum to 100% continuous with fail alarm.

^Note. Models PL440, PLX440, PL980, PLX980 have no overload capability.

### 4 Mechanical Dimensions PL/X 275 - 440

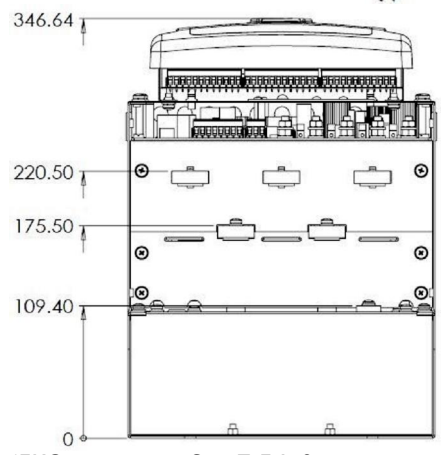
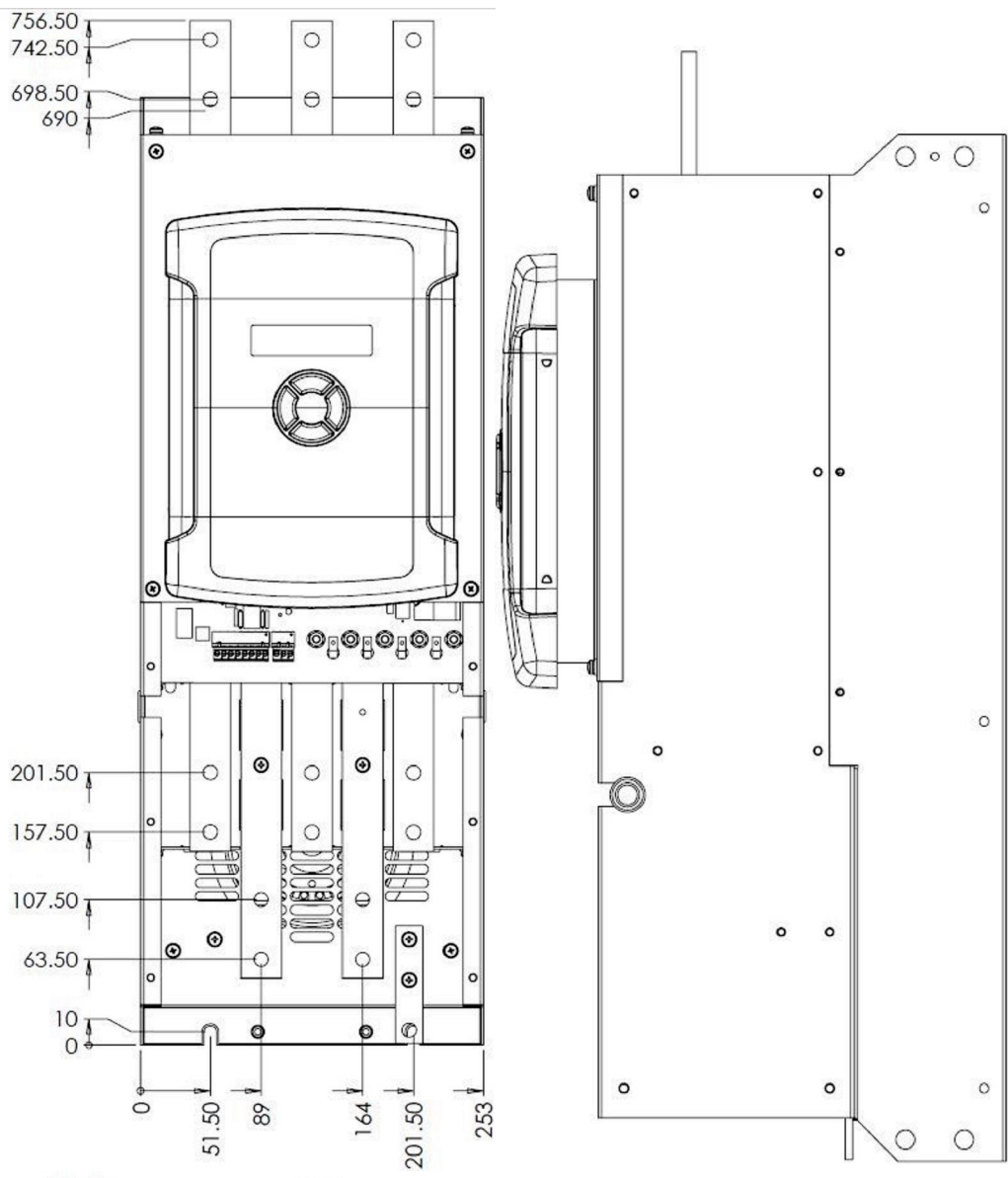

Weight 45KG

See 7.5 Lifting

### 5 Mechanical Dimensions PL/X 520 - 980

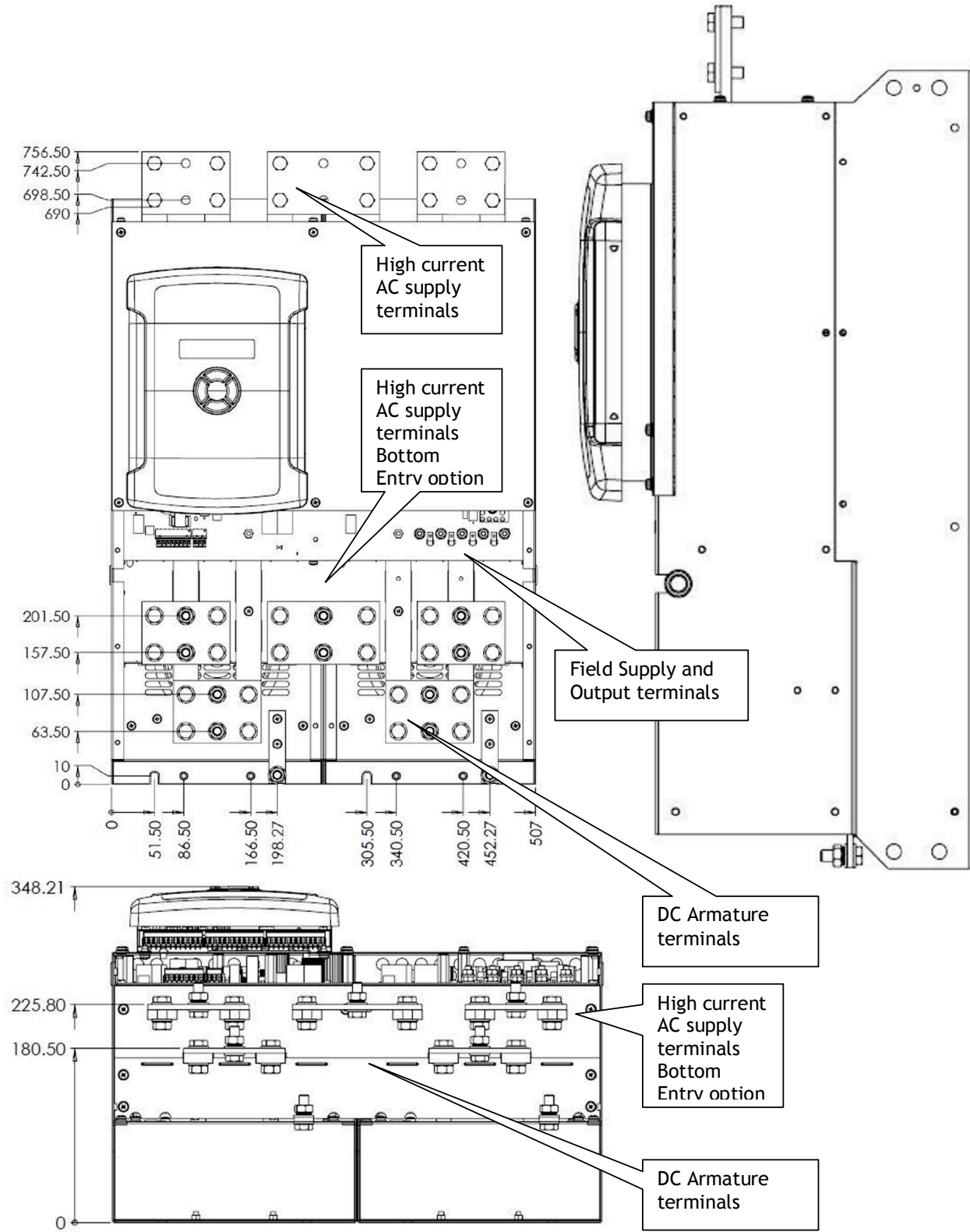

Weight 90KG.

See 7.5 Lifting

## 6 Venting

### 6.1 General venting information

In order to keep these units within the required operating temperatures under all operating limits they are equipped with a very efficient cooling system. It consists of a powerful centrifugal fan system integral to the unit mounted at the bottom, which blows air over a high dissipation heatsink. Cool air is drawn in both at the top and bottom of the unit and after travelling over the internal heatsink fins, is exhausted at the top of the unit. From here the warm air must be vented from the enclosure used to house the drive.

See 4 Mechanical Dimensions PL/X 275 - 440 and 5 Mechanical Dimensions PL/X 520 - 980 for diagram of air exhaust flow. The unit will run cooler and hence be less stressed if the warm exhaust air is prevented from mixing with the intake air. This can be achieved by the use of the optional venting kit. See below.

#### 6.1.1 When venting kit impractical. Models PL/X 275/315/360/520/600

For these models it is usually sufficient to ensure that the enclosure is fitted with exhaust fans that can evacuate air from the enclosure at a rate at least as high as the drive fan, but within the capacity of the enclosure inlet filter. See 3 Rating Table for airflow ratings. When fitting enclosure fans ensure they are placed in the roof of the enclosure directly above the exhaust outlet of the PL/X.

#### 6.1.2 When venting kit impractical. Models PL/X 400/440/700/800/900/980

For these models it is necessary to keep the exhaust air that is emitted from the top end of the fin section separated from the rest of the enclosure by constructing a duct that can evacuate the exhaust air from the enclosure. If this requires an indirect route then you may need to use external fans to maintain the required airflow. See 3 Rating Table for airflow ratings. Ensure against pollutants entering the port and you may need to use a suitable grill if there is a danger of birds or vermin making it their home.

### 6.2 Venting kit for PL/X 275 - 440

The venting kit comprises two steel ducts which are designed to telescope together. Hence the duct length from the top of the drive is adjustable between 270mm to 538mm. It consists of three main components.

1) A lower duct which fits within the side cheeks directly above the heatsink exhaust area.

This is secured with 2 M5 screws. See 4 Mechanical Dimensions PL/X 275 - 440 for fixing point drawing. The lower duct is 270mm long from the top edge of the PL/X.

2) The upper duct, which fits over the lower duct section, to extend the total length of the assembly.

It has a series of M5 side holes to allow adjustment. Once the desired height is established the upper duct can be screwed to the lower duct through the selected hole, one screw per side. The useful length of the extended duct may be adjusted in steps of approx. 20mm from 270mm to 535mm. The duct must be inserted through a tight fitting rectangular hole in the roof of the enclosure (hole size 100mm x 252mm) and protrude above it by 10-20mm. Then the gap between the duct and the enclosure roof must be sealed (e.g. using tape or flexible filler) to ensure that the exhaust air and pollutants cannot enter into the enclosure.

3) A cowl which is fixed on top of the enclosure to prevent pollutants from dropping into the outlet.

The cowl is supplied with 4 off 70mm mounting pillars, and 4 M6 holes must be drilled in the roof of the enclosure, to allow the mounting pillars to be fixed such that the cowl is positioned centrally over the duct. The cowl will overhang the duct by 70mm all the way round. If there is a danger of birds or vermin entering the exhaust port then it is recommend that a suitable grille is added round the edge of the cowl.

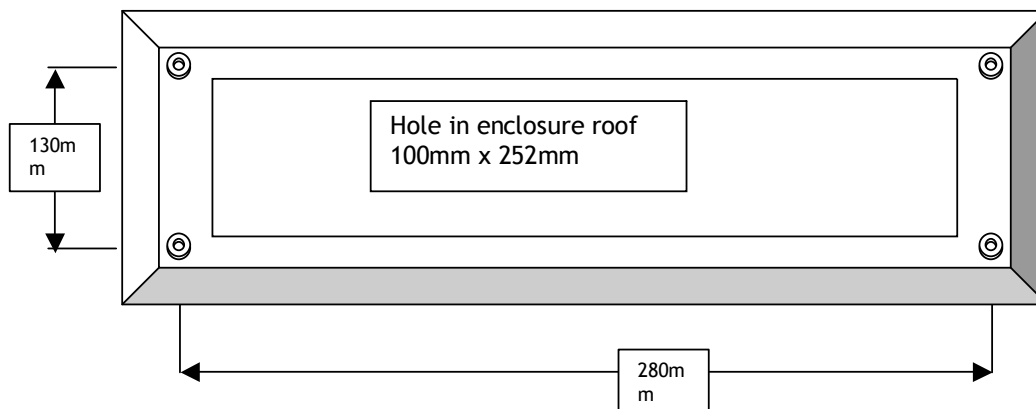

## 6.2.1 PL/X 275 - 440 venting kit diagram

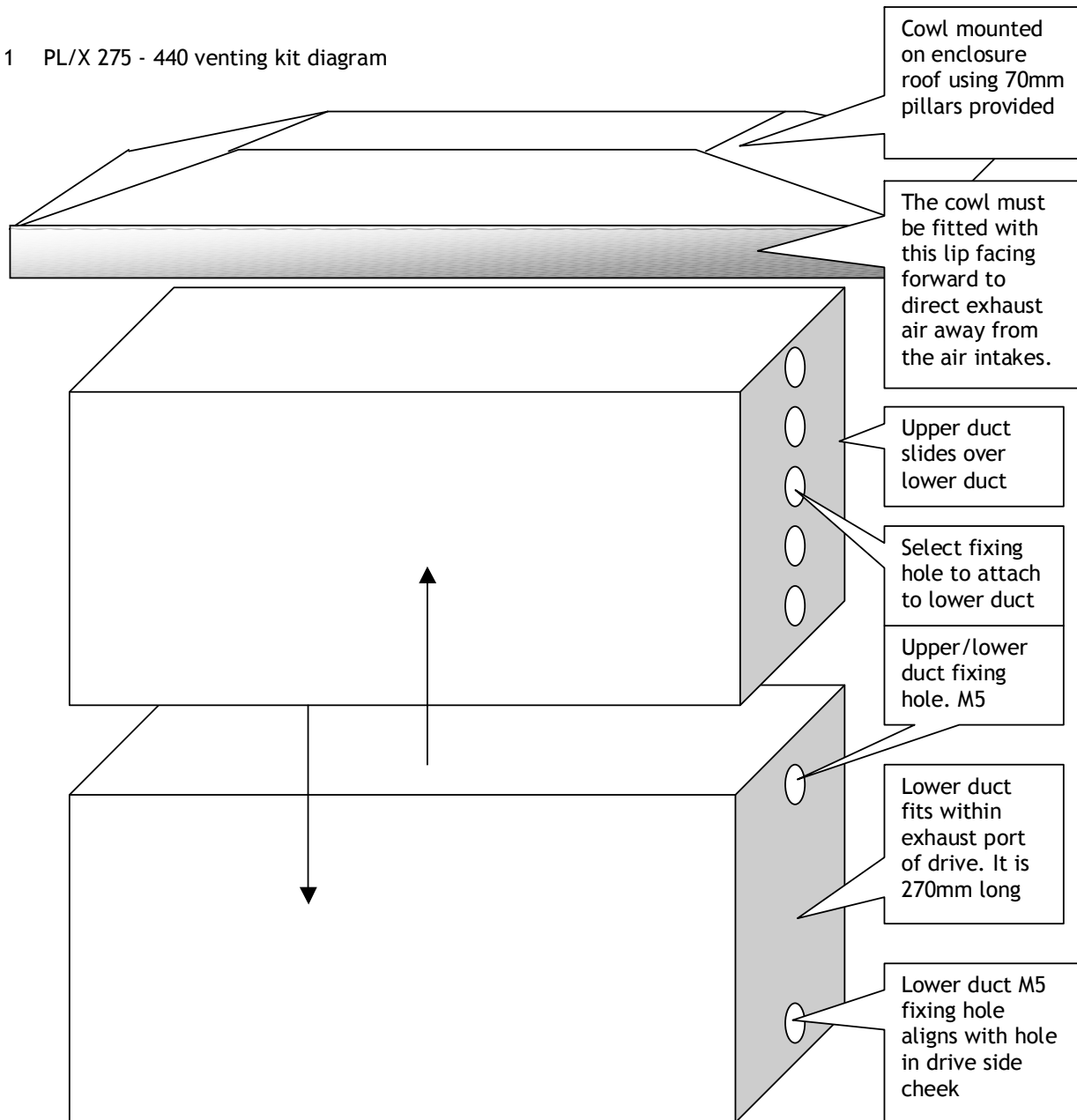

## 6.3 Venting kit for PL/X 520 - 980

The venting kit comprises a cowl and 2 pairs of steel ducts, each pair being designed to telescope together. Hence the duct length from the top of the drive is adjustable between 270mm to 535mm. There is also an enclosure roof cowl. Each pair is the same unit as described in 6.2 Venting kit for PL/X 275 - 440. There are 2 exhaust ports at the top of the PL/X and each pair of ducts is used with one of the ports. Please read section 5.2 for details about each pair.

The ducts must be inserted through a tight fitting rectangular hole in the roof of the enclosure (hole size 100mm x 504mm) and protrude above it by 10-20mm. Then the gap between the duct and the roof must be sealed (e.g. using tape or flexible filler) to ensure that the exhaust air and pollutants cannot enter into the enclosure. Also the interface between each pair of ducts must be sealed at the top where it protrudes from the roof.

The cowl is fixed on top of the enclosure to prevent pollutants from dropping into the exhaust outlet of the drive. The cowl is supplied with 6 off 50mm mounting pillars, and 6 M6 holes must be drilled in the roof of the enclosure, to allow the mounting pillars to be fixed such that the cowl is positioned centrally over the duct. The



cowl will overhang the duct by 70mm all the way round. If there is a danger of birds or vermin entering the exhaust port then it is recommend that a suitable grille is added round the edge of the cowl

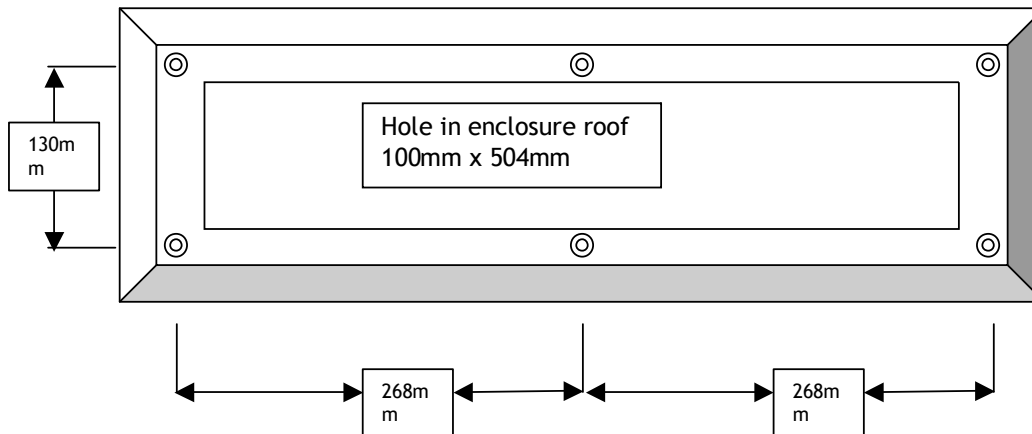

#### 6.4 Air supply to enclosure

It is essential that the enclosure which houses the PL/X is supplied with sufficient cool clean air to satisfy the throughput requirements of the PL/X and any other devices within the enclosure. Do not forget that the current carrying components associated with the drive will be dissipating a considerable amount of heat especially when the system is running at full capacity.

The enclosure must be fitted with air filters suitable for the airborne pollutants encountered within its environment. Together they must have a rated throughput of sufficient capacity for all of the exhaust fans used in the enclosure. If the PL/X is fitted with a venting kit and there is another exhaust fan also operating for cooling other components it is essential that the auxiliary fan does not starve the PL/X of its air supply. This should be avoided if the input filters have sufficient capacity. It is recommended that the PL/X is provided with its own filters, and an enclosure partition used to isolate it from the influence of the rest of the enclosure cooling arrangements.

There should be 2 filters for the PL/X. One to provide air to the lower input port, and one for the upper port. The inlet filters should be fitted to the enclosure adjacent to the input ports at the lower and upper ends of the unit to ensure that the air drawn in is close to where it is needed. The reason for using filters at the top and bottom of the unit is because if only one filter is provided, then when the enclosure door is shut, the airpath from top to bottom may become throttled if the door is close to the face of the unit.

#### 6.5 Exhaust air

After leaving the enclosure containing the PL/X the heated exhaust air will need to be prevented from elevating the ambient temperature of the room that is housing the enclosure by using sufficient ventilation. Alternatively the supply of cooling air may be obtained from outside and ducted to the enclosure.

#### 6.6 Venting summary

Ensure a clean un-interruptible supply of cool filtered air is available for the PL/X and that the exhaust air is adequately and safely disposed of. Use the venting kit to keep the hot exhaust air separate from the cooling input air within the enclosure. Ensure the cooling air is available at the top and bottom of the unit. The PL/X will survive running at high ambient temperatures but possibly at the expense of its potential lifespan. Observe good engineering practice and keep all the components within the enclosure as cool as possible, consistent with avoiding condensation. For installations subjected to high ambient temperatures consider the use of air conditioning to achieve these requirements.

### 6.6.1 Diagram of air flow

This diagram shows a side view of a unit in an enclosure. This is the recommended method for arranging the flow of cooling air. The fan in the PL/X will draw air into the top and bottom air intakes of the unit.

There are 2 air inlet filters mounted on the door. One adjacent to the lower air intake of the unit and the other adjacent to the upper air intake of the unit.

The exhaust air is exiting the enclosure via the venting kit assembly which is shown with the cowl fitted on the roof of the enclosure.

If this hot exhaust air is likely to raise the temperature of the air being drawn in, then further measures must be taken to direct it away from the system.

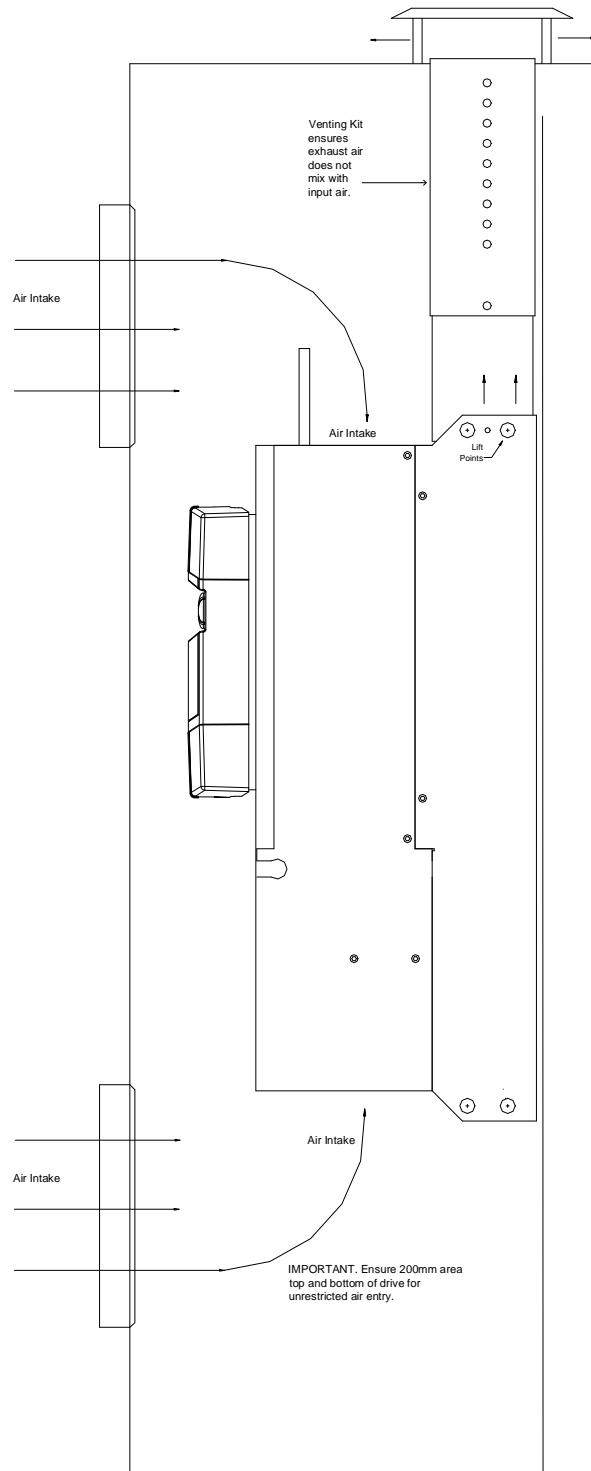

## 7 Product rating table

Model PL 2Q PLX 4Q	Output power				Max continuous Current (AMPS)			Max field DC output Amps		Line reactor type	Cooling air flow and dissipation		
	At OP = 460V 380 -415AC Kw HP		At 500V 480AC HP	At 750V 690AC HP	AC	IP	DC	OP	std		option	cfm	watts
PL/X275	275	370	400	600	530	650	32	50	LR650	400	1700		
PL/X315	315	425	460	690	615	750	32	50	LR750	400	2000		
PL/X360	360	485	520	780	700	850	32	50	LR850	400	2300		
PL/X400	400	540	580	875	780	950	32	50	LR950	400	2500		
PL/X440	440	590	640	970	860	1050	32	50	LR1050	400	2800		
PL/X520	520	700	760	1140	1025	1250	64		LR1250	800	3200		
PL/X600	600	810	880	1320	1190	1450	64		LR1450	800	3700		
PL/X700	700	940	1020	1530	1350	1650	64		LR1650	800	4200		
PL/X800	800	1080	1170	1760	1520	1850	64		LR1850	800	4700		
PL/X900	900	1200	1300	1950	1680	2050	64		LR2050	800	5200		
PL/X980	980	1320	1430	2145	1845	2250	64		LR2250	800	5700		

### Important Notes

- 1) Only use UL fuses for installations complying with UL codes.
- 2) 2Q models PL400/440/700/800/900/980 have a regenerative stopping capability.
- 3) The EL1/2/3 connections require 3 auxiliary fuses, (max ratings 80A, I<sup>2</sup>t 5000).  
Sprint part no. Fuse CH00880A. Fuseholder CP102071  
When selecting alternative types the fuse current rating must typically be 1.25 X the field current rating of the motor. Max ratings 80A, I<sup>2</sup>t 5000.
- 4) Please consider the total component dissipation within the enclosure when calculating the required air throughput. This includes the fuses, line reactors and other sources of dissipation.
- 5) 400 Cubic feet per minute is approximately equivalent to 12 cubic metres per minute.
- 6) The output power rating shown is at the 100% rating of the drive and is the power available at the shaft for a typical motor. The actual power available will depend on the efficiency of the motor.
- 7) The high power field output option is an extra cost option and needs to be specified at the time of order.
- 8) The 690V AC supply is an extra cost option and needs to be specified at the time of order. Suffix HV
- 9) The bottom entry AC supply option needs to be specified at the time of order. Suffix BE
- 10) Models PL/X 900/980 have maximum ambient temperature rating of 35C. Derate by 100 Amps for 40C.
- 11) Derate by 1% per Deg C for ambient temperatures above 40C up to 50C.

### 7.1 Product rating labels

The product rating labels are located on the unit under the upper end cap. The product serial number is unique and can be used by the manufacturer to identify all ratings of the unit. The power ratings and model type are also found here, along with any product standard labels applicable to the unit.

## 7.2 Semiconductor fuses

**WARNING.** All units must be protected by correctly rated semi-conductor fuses. Failure to do so will invalidate warranty. For semi-conductor fuses please refer to supplier.

### 7.2.1 PL and PLX Models AC and DC semiconductor fuses

500V AC Table

Model	Output		Main Fuses		Aux Fuses			Line Reactor	DC Fuses		
	DC Amps	I <sup>2</sup> t [A <sup>2</sup> s]	PartNo	I <sup>2</sup> t [A <sup>2</sup> s]	PartNo	Holder	I <sup>2</sup> t [A <sup>2</sup> s]		PartNo		
PL/X275	650	210,000	CH103301	770	CH00850A	CP102054	LR650	490,000	CH103303		
PL/X315	750	300,000	CH103302	770	CH00850A	CP102054	LR750	700,000	CH103304		
PL/X360	850	490,000	CH103303	770	CH00850A	CP102054	LR850	900,000	CH103305		
PL/X400	950	700,000	CH103304	770	CH00850A	CP102054	LR950	1260,000	CH103306		
PL/X440	1050	900,000	CH103305	770	CH00850A	CP102054	LR1050	1850,000	CH103307		
PL/X520	1250	1260,000	CH103306	4650	CH008100	CP102054	LR1250	2500,000	CH103308		
PL/X600	1450	1850,000	CH103307	4650	CH008100	CP102054	LR1450	1900,000	CH103309		
PL/X700	1650	2500,000	CH103308	4650	CH008100	CP102054	LR1650	2800,000	CH103310		
PL/X800	1850	1900,000	CH103309	4650	CH008100	CP102054	LR1850	3100,000	CH103467		
PL/X900	2050	2800,000	CH103310	4650	CH008100	CP102054	LR2050	4400,000	CH103330		
PL/X980	2250	3100,000	CH103467	4650	CH008100	CP102054	LR2250	6600,000	CH103469		

600/690V AC Table

Model	Output		Main Fuses		Aux Fuses			Line Reactor	DC Fuses		
	DC Amps	I <sup>2</sup> t [A <sup>2</sup> s]	PartNo	I <sup>2</sup> t [A <sup>2</sup> s]	PartNo	Holder	I <sup>2</sup> t [A <sup>2</sup> s]		PartNo		
PL275MV/HV	650	210,000	CH103301	770	CH00850A	CP102054	LR650HV				
PL315MV/HV	750	300,000	CH103302	770	CH00850A	CP102054	LR750HV				
PL360MV/HV	850	490,000	CH103303	770	CH00850A	CP102054	LR850HV				
PL400MV/HV	950	700,000	CH103304	770	CH00850A	CP102054	LR950HV				
PL440MV/HV	1050	900,000	CH103305	770	CH00850A	CP102054	LR1050HV				
PL520MV/HV	1250	1260,000	CH103306	4650	CH008100	CP102054	LR1250HV				
PL600MV/HV	1450	1850,000	CH103307	4650	CH008100	CP102054	LR1450HV				
PL700MV/HV	1650	2500,000	CH103308	4650	CH008100	CP102054	LR1650HV				
PL800MV/HV	1850	1900,000	CH103309	4650	CH008100	CP102054	LR1850HV				
PL900MV/HV	2050	2800,000	CH103310	4650	CH008100	CP102054	LR2050HV				
PL980MV/HV	2250	3100,000	CH103467	4650	CH008100	CP102054	LR2250HV				
PLX275MV/HV	650	485,000	CH103341	770	CH00850A	CP102054	LR650HV	1090,000	CH103343		
PLX315MV/HV	750	640,000	CH103342	770	CH00850A	CP102054	LR750HV	1440,000	CH103344		
PLX360MV/HV	850	1090,000	CH103343	770	CH00850A	CP102054	LR850HV	2130,000	CH103345		
PLX400MV/HV	950	1440,000	CH103344	770	CH00850A	CP102054	LR950HV	2430,000	CH103346		
PLX440MV/HV	1050	2130,000	CH103345	770	CH00850A	CP102054	LR1050HV	3080,000	CH103355		
PLX520MV/HV	1250	2430,000	CH103346	4650	CH008100	CP102054	LR1250HV	4100,000	CH103348		
PLX600MV/HV	1450	3080,000	CH103347	4650	CH008100	CP102054	LR1450HV	4400,000	CH103349		
PLX700MV/HV	1650	4100,000	CH103348	4650	CH008100	CP102054	LR1650HV	5800,000	CH103350		
PLX800MV/HV	1850	4400,000	CH103349	4650	CH008100	CP102054	LR1850HV	8500,000	CH103471		
PLX900MV/HV	2050	5800,000	CH103350	4650	CH008100	CP102054	LR2050HV	9632,000	CH103360		
PLX980MV/HV	2250	8500,000	CH103471	4650	CH008100	CP102054	LR2250HV	12,075,000	CH103472		

7.2.2 PLX Models DC semi-conductor fuses

For PLX units used in applications in which regeneration occurs for most or all of the time, it is recommended to fit a DC side semi-conductor fuse. This will further protect the unit in the event of an un-sequenced power loss when regeneration is taking place

Note. It is not normally necessary to use DC fuses with the PL Models but if required then these fuses can be used. Example. A \*PL model that allows regenerative stopping is employed on a site that suffers from a higher than normal amount of power brown outs or blackouts.

See fuse table above

**7.3 Terminal information**

7.3.1 Control Terminals

See Part 1 main product manual for control terminal information section 3.3.3, 3.4 and 3.5.

7.3.2 Powerboard Terminals

Remove busbar cover plate to reveal powerboard terminals.

For terminals T41 to T53 refer to main manual Part 1 section 3.3.3, for power terminals section 3.3.2.

7.3.2.1 Fan supply input

Remove busbar cover plate to reveal powerboard terminals. The fan supply input terminals are located on the lower left hand edge of the powerboard marked AC FAN SUPPLY B1 N, B2 L.

Internal Fan supply

PL/X 275/315/360/400/440 models need a separate 100VA 240V 50/60Hz ac supply for the fan.

PL/X 520/600/700/800/900/980 models need a separate 200VA 240V 50/60Hz ac supply for the fan.

**Note. If the fan supply fails, or is not present on power up then a warning message HEATSINK OVERTEMP is displayed on the front of the unit, and operation of the motor will be prevented. See also the main manual section 8.1.11.13 for further details of this message related to actual overtemp events.**

7.3.2.2 Field supply input and output

Remove busbar cover plate to reveal powerboard terminals

The terminals EL1 EL2 EL3 F+ F- are M6 stud types found on the bottom right hand corner of the powerboard.

Further information on utilising these terminals is in Section 4 Basic Application and Section 14.9 Wiring instructions, in the main manual. Also section 3.3.2 for specification. See section 7 Product rating table, in this Part 3.

7.3.3 Terminal tightening torques

Terminals	Model	Tightening torque
Terminals 1 to 100	PL/X 275-980	4 lb-in or 0.5 N-m
EL1 EL2 EL3 F+ F-	PL/X 275-980	35 lb-in or 3.9 N-m
L1 L2 L3 A+ A-	PL/X 275-980	242 lb-in or 27 N-m
Fan supply terminals	PL/X 275-980	9 lb-in or 1.0 N-m

7.3.4 Forces applied to the power terminals

Avoid applying mechanical stress to the heavy current terminals L1/2/3 A+ A-. Please ensure that any cables or busbars that are bolted to these terminals are supported within the enclosure. Do not rely on the drive terminals to support the weight of the external connections.

Do not use the connecting bolt to hold the terminal and the connecting cable or busbar in alignment, otherwise, if they have been levered into alignment prior to inserting the bolt, there will be a permanent stress on the terminal. Always support the connection to the terminal such that the only purpose of the terminal bolt is to tighten them together and not to maintain their relative position to each other. The respective holes in the terminal and the connecting busbar should remain in alignment without the aid of the terminal bolt. Then you can be sure that there is minimum stress on the drive terminal busbar.

When tightening the connecting bolts of the terminals L1/2/3 A+ A- please ensure that the busbar is not subjected to a turning moment as the nut is torqued down. To do this always use two spanners, one on the bolt head to provide a counter torque and one on the nut to provide tightening torque.

#### 7.3.5 Avoid dropping small objects into unit

If the unit is in the horizontal plane then there is a danger that objects may be accidentally dropped into the air intake grille when connecting the busbars to the terminals. Or when the unit is vertical, dropping washers into the fin section at the top, or objects dropping through the upper air intake grill. As a precaution it is advised that a temporary cover be utilised over these areas when working on the unit, e.g. a piece of cardboard. Do not forget to remove the temporary cover prior to starting the unit. If anything is dropped into the unit then it may interfere with the fan rotation.

### 7.4 Line reactors

Only use UL certified line reactors for installations complying with UL codes. These line reactors are not certified. Refer to supplier for certified alternatives.

Model PL 2Q PLX 4Q	Max continuous Current (AMPS)		Line reactor Type 500V AC Supply	Line reactor Type 600V AC Supply	Line reactor Type 690V AC Supply
	Input AC	Output DC			
PL/X275	530	650	LR650	LR650HV	LR650HV
PL/X315	615	750	LR750	LR750HV	LR750HV
PL/X360	700	850	LR850	LR850HV	LR850HV
PL/X400	780	950	LR950	LR950HV	LR950HV
PL/X440	860	1050	LR1050	LR1050HV	LR1050HV
PL/X520	1025	1250	LR1250	LR1250HV	LR1250HV
PL/X600	1190	1450	LR1450	LR1450HV	LR1450HV
PL/X700	1350	1650	LR1650	LR1650HV	LR1650HV
PL/X800	1520	1850	LR1850	LR1850HV	LR1850HV
PL/X900	1680	2050	LR2050	LR2050HV	LR2050HV
PL/X980	1845	2250	LR2250	LR2250HV	LR2250HV

To obtain line reactor dimensions please refer to supplier

### 7.5 Lifting the unit

Use the lifting points provided. There are lifting holes at each end of the unit. Attach a loop of suitable rope (approx. 1.2m for PL/X275-440 and 1.5m for PL/X520-980) between the lifting holes at each side at the top end, and a similar loop at the bottom end, to assist in lifting the unit out of its container. When lifting the unit keep it in either the horizontal or vertical plane to avoid deforming the side cheeks at the lifting points. Use the top end lifting loop to assist in presenting the unit onto the back panel. The fixing holes at the top of the unit are designed with a keyhole shape to allow the unit to be initially hung on the securing bolts. These should be fixed on the back panel prior to presenting the unit into the enclosure.

Alternatively a small fork lift may be employed if the wheel has access under the door of the enclosure. (It is usually possible to have access for one fork from the side of a typical enclosure with the side panel removed). If access can be gained this way then you will need to bolt some temporary wooden extensions to the lifting holes at the bottom of the unit in order to stand the unit on the fork which will enter the enclosure).

#### 7.5.1 Unit weight

The PL/X 275-440 weighs 45Kg. The PL/X 520-980 weighs 90Kg.





**Sprint Electric Limited  
Peregrine House  
Ford Lane,  
Arundel, BN18 0DF, UK**

**Tel.           +44 (0)1903 558080  
Fax.           +44 (0)1243 558099  
Email.        info@sprint-electric.com**

**[www.sprint-electric.com](http://www.sprint-electric.com)**